



STUDIO COPY

KITCHEN APPLIANCES.

Collection 25



Contents.

INTRODUCTION 03

Transform your kitchen experience with state-of-the-art appliances that seamlessly blend innovative designs, energy efficiency, and smart technology. Elevate your lifestyle as you explore ground-breaking features in every corner.

OVENS 10

There's a Caple oven for every kind of kitchen and every type of lifestyle. Choose from our smart-tech Sense Premium range, sleek and elegant SENSE range or our exceptionally versatile Classic range.

MICROWAVES + STEAM OVENS 38

Can't choose between the two? Why not opt for a combination microwave and steam oven. A must-have for a busy lifestyle.



COFFEE MACHINES 50

Combining the subtle art of the barista with the very latest in coffee machine technology. Caple gives you perfect coffee at the touch of a button.

WARMING + STORAGE DRAWERS 54

Caple's warming drawers keep tableware at just the right temperature for when the food is ready to be served.

Why not add a storage drawer too? It's a convenient and stylish way to organise your coffee and wine accessories.

HOBBS 60

Whether you choose gas, electric or induction, Caple's advanced technology and unswerving eye for detail means real control and stylish good looks every time.

EXTRACTION 90

A well-engineered extractor hood does more than just help to capture odours from your kitchen. Be bold, and use it as a visual focal point too.



SPLASHBACKS 138

The perfect finishing touch.

REFRIGERATION 144

Whether you want a discreet space-saving under-counter fridge or something more spacious, you'll find it right here.



WINE CABINETS 162

Caple's wine cabinets create the optimum storage conditions for your wine; the correct temperature, humidity and air circulation. They even use low vibration technology to minimise disturbance.

DISHWASHERS 196

Happily our reliable dishwashers will give you load after load of squeaky-clean pans and glassware that sparkles like new.



LAUNDRY 202

A reliable washing machine and tumble dryer is an absolute must for any family. We've taken things further, with a range that's packed with features, good looks and performance.

PLINTH HEATERS 212

Choose from hydronic or electric models with Stainless Steel or white grills.



WASTE DISPOSAL UNITS 214

A waste disposer hidden away under the sink can help you recycle your food. It's clean, it's green and it leaves less to clutter up your bin.

INSTALLATION DRAWINGS 216

Explore a collection of installation drawings at the back of the brochure - your guide to seamless set-ups. Dive into detailed visuals to streamline your installation.

Making Functionality Fashionable.

Beautiful, functional and technologically advanced, Caple appliances are central to the concept of a contemporary kitchen. From super sleek induction hobs to discretely effective cooker hoods, whisper quiet dishwashers and smart [in every sense] wine cabinets, they cater for every lifestyle.

Chef, entertainer, home maker? Whatever your passion Caple provides the inspiration to carry it off with exceptional style. Our range offers the depth and versatility to seamlessly integrate into your kitchen, whatever its design or layout. Discover exciting new ways to cook, cool or wash, but above all, bring out the beating heart of your home.





COOKING

OVENS	10
MICROWAVES + STEAM OVENS	38
COFFEE MACHINES	50
WARMING + STORAGE DRAWERS	54
HOBS	60
EXTRACTION	90
VENTING	136
SPLASHBACKS	138

Cooking The Way You Want.

BASE HEAT	TOP HEAT	CONVENTIONAL HEAT	FAN HEAT	FAN HEAT WITH BASE HEAT
Bottom element only Removes the need to blind bake	Top element only Gentle heat to brown the top of a dish	Top and bottom elements Cooking consistently through to the middle Best results, use one shelf only	Fan element Fast and highly efficient even cooking	The heat produced by the circular and bottom elements is evenly distributed by the fan
PERFECT FOR Pastries and cakes	PERFECT FOR Pasta or potato dishes	PERFECT FOR Baking	PERFECT FOR Juicy roasts, no pre-heat required	PERFECT FOR Perfectly cooked quiches and tarts with no blind baking

FAN HEAT WITH TOP + BASE HEAT	FAN HEAT + GRILL	TURBO CONVENTIONAL HEAT	FULL GRILL	ECO GRILL
Combining conventional heat with fan heat for intense even cooking	Fan element and full grill Heat from both rear and upper elements	Fan assisted top and bottom elements Fast and even heat distribution without transferring smells or tastes	Full width grill Even and consistent grilling	Half width grill Energy saving inner grill section only
PERFECT FOR Crusty bread and perfectly cooked pies	PERFECT FOR Finishing off a cooked dish, or melting cheese without the worry of overcooking	PERFECT FOR Light and delicate baking, such as pastry or bread	PERFECT FOR Large pieces of steak or fish	PERFECT FOR Small portions of food, such as bacon or toast

Please note, function icons may vary slightly from Classic, Sense and Sense Premium.

TURBO GRILL	TURBO ECO GRILL	TURBO BASE HEAT	FRESH PIZZA
Fan assisted full grill Even and quick browning	Fan assisted half grill Even & quick browning for smaller dishes	Fan assisted bottom element Designed for delicate and slow cooking	Utilises a 345°C setting which cooks fresh pizza in 2 minutes 45 seconds
PERFECT FOR Cooking meat whilst keeping all the juices	PERFECT FOR Potato gratin or lasagne	PERFECT FOR Slow cooked lamb, or eliminating the need for blind baking	PERFECT FOR Homemade Italian-style Pizza

ROAST	DEHYDRATE	SLOW COOK	PROVING
Fan heat The Roast function automatically raises the oven to 250°C to sear the meat then drops to your chosen temperature	Fan heat This function uses fan heat, with a pre-set temperature of 60°C with options to select 50°C and 70°C	Top & bottom element Slow cooking over a long period of time at 90°C using conventional heat	Bottom element This function uses base heat at a temperature of 30°C
PERFECT FOR Sealing in all the flavours & perfect crackling on your pork joint	PERFECT FOR Drying fruit	PERFECT FOR Casseroles and stew	PERFECT FOR Proving dough

Please note, function icons may vary slightly from Classic, Sense and Sense Premium.

Cooking The Way You Want.

SABBATH	PYROLYTIC SELF-CLEANING	WARM	WARM+
S	P		
Top and bottom elements Uses conventional heat with a selectable time of up to 72 hours, and a selectable temperature of 70°C to 140°C	Works by heating the oven to 475°C, causing even hidden & baked-on grime to carbonise into a fine ash for easy cleaning	Bottom element A pre-set temperature of 40°C, with options to select 30°C and 50°C	Bottom element A pre-set temperature of 75°C, with option to select 100°C
PERFECT FOR Observing the Sabbath day	PERFECT FOR Taking the effort out of cleaning	PERFECT FOR Warming plates and serving dishes	PERFECT FOR Keeping food warm

MICROWAVE	MICROWAVE + FAN HEAT	MICROWAVE + TURBO GRILL	MICROWAVE + STEAM
Standard microwave cooking function	Fan heat and microwave Reduce cooking times with the addition of fan heat for even cooking	Microwave, fan and grill Quick browning, ideal for cooking meat & keeping all the juices	Microwave and steam Operate alternatively to cook your food quickly and healthily
PERFECT FOR Ideal for reheating leftovers	PERFECT FOR Fluffy jacket potatoes with a crispy skin in a quarter of the time	PERFECT FOR Cooking a whole chicken	PERFECT FOR Steam puddings

Please note, function icons may vary slightly from Classic, Sense and Sense Premium.

MICROWAVE + CONVENTIONAL HEAT	STEAM	STEAM+	GRILL + STEAM	TURBO GRILL + STEAM
		STEAM+		
Uses microwave with top and bottom elements	Steam Injection No transfer of flavours Retains moisture and locks in nutrients One of the healthiest cooking methods	Steam Injection To be used with certain functions to add an injection of moisture into the cooking process	Top element and grill with steam injection Both the top element and grill operate together to grill larger quantities of food Combined with steam to help preserve moisture and flavours in food	Fan assisted grill with steam injection The fan aids the distribution of heat from the grill evenly and with added steam ensures your food retains all its moisture
PERFECT FOR Speeding up baking times for bread and cakes	PERFECT FOR Cooking multiple food types on one tray	PERFECT FOR Achieving restaurant quality results	PERFECT FOR Succulent chops & steaks	PERFECT FOR Evenly cooked sausages or burgers

FAN HEAT + STEAM	DEFROST / TURBO DEFROST	AUTO SETTINGS	BOOST	DESCALE
		AUTO	BOOST	
Fan element and steam injection Even heat distribution with the added benefit of the steam injecting moisture into the cavity	Fan This function is used to defrost food	A range of automatic settings for milk, soup, vegetables, noodles, bread, fish, meat and chicken	Rapidly heat your oven to the required temperature using all elements at full power. Ideal for when you're in a rush	Pour in the descaler into the water tank, select this function and let the machine do the rest. This is recommended every three months
PERFECT FOR Retaining the moisture in meat	PERFECT FOR Frozen desserts	PERFECT FOR Making soup from scratch	PERFECT FOR When cooking time is less than 20 minutes	PERFECT FOR Prolonging the life of your steam oven

Please note, function icons may vary slightly from Classic, Sense and Sense Premium.

Ovens.

There's a Caple oven for every kind of kitchen and every type of lifestyle. Choose from our smart-tech Sense Premium range, sleek and elegant SENSE range or our exceptionally versatile Classic range.



Let's Compare.



Classic.

If you're after affordability, then our Classic range is the perfect cost effective product. Classic comes with a range of standard and optional features, including pyrolytic cleaning.



Sense.

A step up from the Classic collection, our SENSE range features soft close doors, rotisserie racks & intuitive touch controls depending on the model you choose.



Sense Premium.

Our Sense Premium collection is our most advanced collection to date. Featuring smart technology, WiFi connectivity, 23 functions and intuitive design which can be controlled from your phone.

	C CLASSIC	S SENSE	sp SENSE PREMIUM
FUNCTIONS	5 - 11 Functions	8 - 14 Functions	23 Functions
CONTROLS	Dial and Touch Controls	Touch Controls	CapleTouch+ TFT Touch Controls
WIFI CONNECTIVITY	-	-	Yes
ENERGY	A	A	A
2 X TELESCOPIC RUNNERS	C2239 Only	Yes	Yes
SELF-CLEANING CATALYTIC LINERS	-	C2106BG, C2105SS, C2106GM, C2902BG, C2902SS, C2902GM, C2101BG & C2106BG	-
MOTIONHEAT+	Yes	Yes	Yes
SOFT-CLOSE	-	C2106BG, C2105SS & C2106GM	-
CAPACITY	67	67	67
PYROLYTIC CLEANING	C2239 Only	C2403BG, C2402SS & C2403GM	Yes
ROTISSERIE	-	C2106BG, C2105SS, C2106GM, C2902BG, C2902SS & C2902GM	Yes
DOORS	Double or Quadruple Glazed	Triple or Quadruple Glazed	Quadruple Glazed
COMPATIBLE WITH CAPLEHOME APP	-	-	Yes
MULTI-STAGE COOKING	-	-	Yes
FAVOURITES	-	-	Yes
MEAT PROBE	-	-	Yes

Sense Premium.

#WHENPREMIUMMAKESSENSE

Introducing Sense Premium cooking.

Smart technology, WiFi connectivity, 23 functions and intuitive features all controlled from your phone. Sense Premium ovens will revolutionise the way you cook forever. Designed with you in mind.

Complete the look with a coffee machine and wine cabinet designed to match the Sense Premium aesthetic to achieve show stopping results.

The CapleHome App is available to download on Android and iOS.

sp Look out for products marked with Sense Premium flags to easily identify the range.





Features + Functions.

CAPLE RECIPES + FAVOURITES

Use the CapleHome App to access the latest recipes, save your multi-stage cooking settings and add your family favourites.

MULTI-STAGE COOKING

Some dishes require multiple functions at different stages of cooking. Multi-stage cooking does this for you without the fuss.

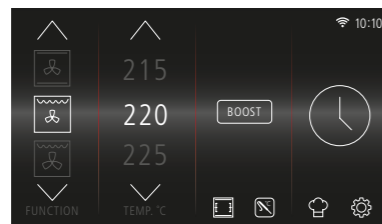
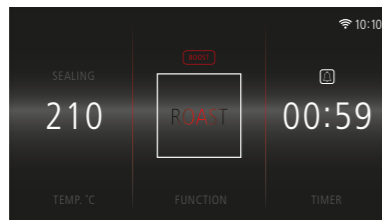
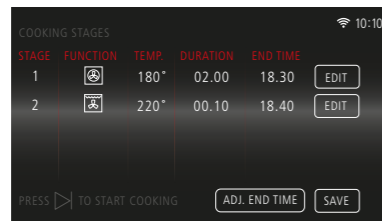

AIR FRYER

Transform your oven into an air fryer using the optional extra AIRFRY/AIRFRY2 tray for a healthier way to cook.

PROVE

Create the perfect dough using the prove function which uses base heat at a temperature of 30°C.

WARM+

Uses base heat, with a pre-set temperature of 75°C or 100°C to keep your food warm, just in case someone is running late!



WIFI CONNECTIVITY

The Sense Premium cooking range features WiFi connectivity.



CAPLE HOME

Download the Caple Home app available on Android or iOS.



PIZZA

Create the perfect pizza in 2 minutes 45 seconds. Choose from thin & crispy or deep pan & the oven will then do the rest for you!

MEAT PROBE

Insert the probe into the meat. The meat probe icon will automatically display on the screen to set the core temperature. Once core temperature is reached the oven will turn off to ensure the meat is cooked perfectly.

DEHYDRATE

This function uses fan heat, with a pre-set temperature of 60°C with options to select 50°C and 70°C.

STEAM

The steam function temperature ranges from 40-100°C and automatically sets duration to 20 minutes. However cooking time can range from 1min to 9hrs 59 minutes.

MICROWAVE + TURBO GRILL

Uses microwave, fan and grill for quick browning. Great for cooking a whole chicken.

MICROWAVE + STEAM

Starting with the steam function the temperature increases to 100°C. The microwave and steam functions then alternate for speedy results and maximum flavour.



CAPLETOUCH+

Sense Premium cooking features CapleTouch+. Scroll through functions and save your favourite settings with ease. It takes the guess work out of cooking. All controlled by your CapleHome app.



WANT TO SEE MORE?

Scan the QR code for more information on the next generation of WiFi ovens.



SENSE PREMIUM SMART TECH PYROLYTIC SINGLE OVENS



PRODUCT CODE

sp C2601BG

DIMENSIONS

w:600mm

PERFORMANCE

e Energy class A

FINISH AVAILABLE

Black Steel

FEATURES



iOS



Android

GET CONNECTED

Scan the QR Codes to access a step-by-step guide to connect your smart device to your oven.

- Proving
- Warm
- Warm+
- Defrost
- Boost [rapid preheat]

OVEN FEATURES

- WiFi connectivity
- Compatible with CapleHome App
- CapleTouch+ TFT Touch control
- MotionHeat+ technology
- Convert oven into an air fryer [AIRFRY2]
- Multi-stage cooking
- Favourites: Save your preferred cooking settings
- 67 Litre capacity
- Programmable timer
- Pyrolytic self-cleaning
- Easy clean enamel interior
- Two internal lights
- Child safety lock
- 5 cooking levels
- Closed door grilling
- Rotisserie cooking
- Easy to remove chrome shelf racks
- Quadruple glazed door
- Adjustable display brightness
- Night mode
- Demo mode
- Meat probe
- AutoTime [counts up]

- Full width inner door glass
- Tangential cooling fan

DESIGN

- Black square bar handle
- Colour display

ACCESSORIES

- 1 Air fry tray
- 1 Enamelled grill rack
- 1 Rotisserie
- 1 Meat probe
- 2 Safety-stop shelves
- 1 Grill pan with handle
- 2 Sets of full extension telescopic runners
- 1 Air fry tray [AIRFRY2]
- 1 Grill rack [ERACKPYRO]
- 1 Wire shelf [SHELF4]
- 1 Baking tray [TRAY4]
- 1 Pizza stone [PIZZASTONE]
- 1 Pizza peel [PIZZAPEEL]

OPTIONAL EXTRAS

- 1 Air fry tray [AIRFRY2]
- 1 Grill rack [ERACKPYRO]
- 1 Wire shelf [SHELF4]
- 1 Baking tray [TRAY4]
- 1 Pizza stone [PIZZASTONE]
- 1 Pizza peel [PIZZAPEEL]
- Pair of full extension telescopic runners [CAPRACK8]
- Shelf end cover [SHELF4COV/SS and SHELF4COV/BK]
- Metallic handles available [see p.190 for full range] Visit caple.co.uk for full range

INSTALLATION

- Diagram [p.216]
- Rated load 3.57kW
- Fuse rating 16A

FUNCTIONS

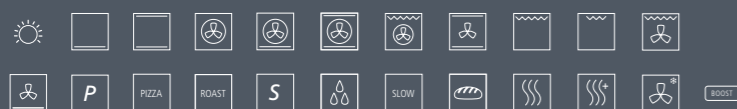

C2601BS



C2601GM



C2600SS

SENSE PREMIUM SMART TECH PYROLYTIC SINGLE OVENS

PRODUCT CODE

- sp** Black Steel C2601BS
- sp** Gunmetal C2601GM
- sp** Stainless Steel C2600SS

DIMENSIONS

w:600mm

PERFORMANCE

e Energy class A

FINISH AVAILABLE

- Black Steel
- Gunmetal with Black Glass
- Stainless Steel with Black Glass

FUNCTIONS

23 Functions

- Light
- Base heat
- Conventional heat
- Fan heat
- Fan heat and base heat
- Fan heat with top and base heat
- Fan heat and grill
- Turbo conventional heat
- Full grill
- Eco grill
- Turbo grill
- Turbo base heat
- Pyrolytic self cleaning
- Classic pizza
- Roast
- Sabbath
- Dehydrate
- Slow cook
- Proving
- Warm
- Warm+
- Defrost
- Boost [rapid preheat]
- WiFi connectivity
- Compatible with CapleHome App
- CapleTouch+ TFT Touch control
- MotionHeat+ technology
- Convert oven into an air fryer [AIRFRY2]
- Multi-stage cooking
- Favourites: Save your preferred cooking settings
- 67 Litre capacity
- Programmable timer
- Pyrolytic self-cleaning
- Easy clean enamel interior
- Two internal lights
- Child safety lock
- 5 cooking levels
- Closed door grilling
- Rotisserie cooking
- Easy to remove chrome shelf racks
- Quadruple glazed door
- Adjustable display brightness
- Night mode
- Demo mode
- Meat probe
- AutoTime [counts up]
- Full width inner door glass
- Tangential cooling fan

DESIGN

- Black square bar handle [C2601BS and C2601GM]
- Stainless Steel square bar handle [C2600SS only]
- Colour display

ACCESSORIES

- 1 Air fry tray [C2601BS and C2601GM]
- 1 Enamelled grill rack
- 1 Rotisserie
- 1 Meat probe
- 2 Safety-stop shelves
- 1 Grill pan with handle
- 2 Sets of full extension telescopic runners

OPTIONAL EXTRAS

- 1 Air fry tray [AIRFRY2]
- 1 Grill rack [ERACKPYRO]
- 1 Wire shelf [SHELF4]
- 1 Baking tray [TRAY4]
- 1 Pizza stone [PIZZASTONE]
- 1 Pizza peel [PIZZAPEEL]
- Pair of full extension telescopic runners [CAPRACK8]
- Shelf end cover [SHELF4COV/SS and SHELF4COV/BK]
- Metallic handles available [see p.190 for full range] Visit caple.co.uk for full range

INSTALLATION

- Diagram [p.216]
- Rated load 3.57kW
- Fuse rating 16A

FEATURES

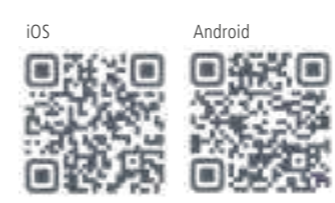

GET CONNECTED

Scan the QR Codes to access a step-by-step guide to connect your smart device to your oven.



FINAL TOUCH

See page 190 for our collection of metallic handles to add that final touch of luxury.

FUNCTIONS

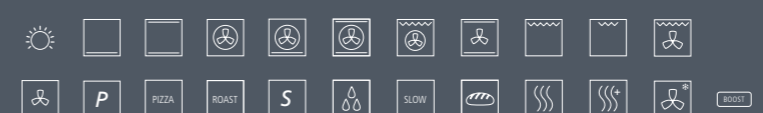



SENSE.

Choose from sultry Black Glass, subtle contemporary Gunmetal, or a modern take on traditional steel. Sense appliances have been designed to fit together effortlessly and will turn heads in any kitchen. Featuring innovative touch control technology, every Sense oven delivers outstanding results, whatever the cooking task.

S Look out for products marked with Sense flags to easily identify the range.

COMPLETELY SEAMLESS

Complete your kitchen's sleek look with shelf end covers. Seamlessly blend cabinets and appliances to create a professional and cohesive finish by adding this final detail.



MotionHeat+

MotionHeat+ technology utilises specially designed vents and fan heat to evenly distribute hot air around the oven cavity. It reaches the desired temperature rapidly with no need to preheat, saving time and energy. Perfect for multi-level cooking without the transfer of flavours, achieving even results every time.

PRECISION CONTROL AT YOUR FINGERTIPS

Our SENSE range features fully-programmable touch controls for precise and accurate cooking temperatures and times. Although, if you prefer the tactile feel of fixed dials, opt for the C2362 with solid metal controls.

TELESCOPIC RUNNERS

All SENSE ovens come with two full extension telescopic runners making it easier to check food as it cooks and reducing the risk of burning yourself on the oven interior.



ROTISSERIE

If you like perfect joints, opt for a SENSE oven that features a rotisserie rack, great for cooking succulent roasts.

PYROLYTIC OVENS

Pyrolytic technology works by heating the oven to 475°C, causing even hidden & baked-on grime to carbonise into a fine ash. It saves you vast amounts of elbow grease, and can in-fact improve oven efficiency over time.

SOFT CLOSE

Opt for a model with a clever soft close door which activates when the door is inches away from the closed position. The hinge gently moves the door into place, preventing it from coming to an abrupt close.



SENSE ELECTRIC 90CM SINGLE OVENS



C2902BG

PRODUCT CODE

- S** Black Glass C2902BG
- S** Gunmetal C2902GM
- S** Stainless Steel C2902SS

DIMENSIONS

↔ w:900mm

PERFORMANCE

e Energy class A

FINISH AVAILABLE

- Black Glass
- Gunmetal with Black Glass
- Stainless Steel with Black Glass

FUNCTIONS

13 Functions

- Light
- Base heat
- Conventional heat
- Fan heat
- Fan heat + grill
- Turbo conventional heat
- Full grill
- Eco grill
- Turbo eco grill
- Turbo grill
- Turbo base heat
- Defrost
- Boost [rapid preheat]

OVEN FEATURES

- MotionHeat+ technology
- 96 Litre XL capacity
- Full touch control
- Programmable electronic timer
- Self-cleaning catalytic liners [back and sides]
- Easy clean enamel interior
- Two internal lights
- Closed door grilling
- Rotisserie cooking
- Easy to remove chrome shelf racks
- Triple glazed door
- Full width inner door glass
- Tangential cooling fan

DESIGN

- Black square bar handle [C2902BG and C2902GM]
- Stainless Steel square bar handle [C2902SS only]
- White LED display

ACCESSORIES

- 2 Safety-stop shelves
- 1 Grill pan with handle
- 2 Sets of full extension telescopic runners
- 1 Rotisserie rack

OPTIONAL EXTRAS

- 1 Air fry tray [AIRFRY2]
- 1 Pizza stone [PIZZASTONE]
- 1 Pizza peel [PIZZAPEEL]

INSTALLATION

- Diagram [p.216]
- Rated load 3.65kW
- Fuse rating 16A

FUNCTIONS

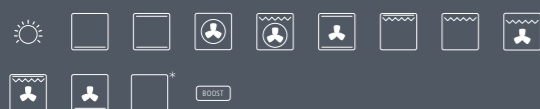

SENSE ELECTRIC PYROLYTIC SINGLE OVENS



C2403BG



C2403GM



C2402SS

PRODUCT CODE

- S** Black Glass C2403BG
- S** Gunmetal C2403GM
- S** Stainless Steel C2402SS

DIMENSIONS

↔ w:600mm

PERFORMANCE

e Energy class A

FINISH AVAILABLE

- Black Glass
- Gunmetal with Black Glass
- Stainless Steel with Black Glass

FUNCTIONS

14 Functions

- Light
- Base heat
- Conventional heat
- Fan heat
- Turbo grill plus fan heat
- Turbo conventional heat
- Full grill
- Eco grill
- Turbo grill
- Turbo base heat
- Turbo eco grill
- Pyrolytic self cleaning
- Defrost
- Boost [rapid preheat]

OVEN FEATURES

- MotionHeat+ technology
- 67 Litre capacity
- Full touch control
- Pyrolytic self-cleaning
- Easy clean enamel interior
- Two internal lights
- Closed door grilling
- Easy to remove chrome shelf racks
- Quadruple glazed door
- Full width inner door glass
- Tangential cooling fan

DESIGN

- Black square bar handle [C2403BG and C2403GM]
- Stainless Steel square bar handle [C2402SS]
- White LED display

ACCESSORIES

- 2 Safety-stop shelves
- 1 Grill pan with handle
- 2 Sets of full extension telescopic runners

OPTIONAL EXTRAS

- 1 Air fry tray [AIRFRY2]
- 1 Wire shelf [SHELF4]
- 1 Baking tray [TRAY4]
- 1 Pizza stone [PIZZASTONE]
- 1 Pizza peel [PIZZAPEEL]
- Pair of full extension telescopic runners [CAPRACK8]
- Shelf end cover [SHELFCOV/SS and SHELFCOV/BK]
- Metallic handles available [see p.190 for full range]

INSTALLATION

- Diagram [p.216]
- Rated load 3.22kW
- Fuse rating 16A

FEATURES



PYROLYTIC CLEANING

The Pyrolytic technology works by heating the oven to 475°C, causing even hidden & baked-on grime to carbonise into a fine ash. It saves you vast amounts of elbow grease, & actually improves oven efficiency over time too.



FINAL TOUCH

See page 190 for our collection of metallic handlesto add that final touch of luxury.

FUNCTIONS

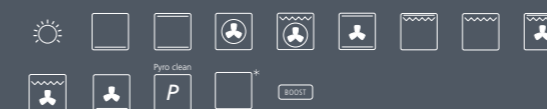

SENSE ELECTRIC SOFT CLOSE SINGLE OVENS

MotionHeat+



C2106BG

PRODUCT CODE

S	Black Glass	C2106BG
S	Gunmetal	C2106GM
S	Stainless Steel	C2105SS

DIMENSIONS

↔ w:600mm

PERFORMANCE

e Energy class A

FINISH AVAILABLE

■	Black Glass
■	Gunmetal and Black Glass
■	Stainless Steel and Black Glass

FUNCTIONS

13 Functions

- Light
- Base heat
- Conventional heat
- Fan heat
- Turbo grill plus fan heat
- Turbo conventional heat
- Full grill
- Eco grill
- Turbo grill
- Turbo eco grill
- Turbo base heat
- Defrost
- Boost [rapid preheat]

OVEN FEATURES

- MotionHeat+ technology
- 67 Litre capacity
- Full touch control
- Soft-close door

FEATURES

SOFT CLOSE

The intuitive soft close hinge prevents the door from shutting abruptly bringing it gently into position.



ROTISSERIE

Perfect joints, the rotisserie is great for cooking succulent roasts.



- Self-cleaning catalytic liners [back and sides]
- Easy clean enamel interior
- Two internal lights
- Closed door grilling
- Rotisserie cooking
- Easy to remove chrome shelf racks
- Triple glazed door
- Full width inner door glass
- Tangential cooling fan

DESIGN

- Black square bar handle [C2106BG and C2106GM]
- Stainless Steel square bar handle [C2105SS only]
- White LED display

ACCESSORIES

- 2 Safety-stop shelves
- 1 Grill pan with handle
- 2 Sets of full extension telescopic runners
- 1 Rotisserie rack

OPTIONAL EXTRAS

- 1 Air fry tray [AIRFRY2]
- 1 Wire shelf [SHELF4]
- 1 Baking tray [TRAY3]
- 1 Pizza stone [PIZZASTONE]
- 1 Pizza peel [PIZZAPEEL]
- Pair of full extension telescopic runners [CAPRACK8]
- Shelf end cover [SHELFCOV/SS and SHELFCOV/BK]
- Metallic handles available [see p.190 for full range] Visit caple.co.uk for full range

INSTALLATION

- Diagram [p.216]
- Rated load 3.22kW
- Fuse rating 16A

SENSE ELECTRIC SINGLE OVEN

MotionHeat+



PRODUCT CODE

S C2101BG

DIMENSIONS

↔ w:600mm

PERFORMANCE

e Energy class A

FINISH AVAILABLE

■ Black Glass

FUNCTIONS

10 Functions

- Light
- Base heat
- Conventional heat
- Fan heat
- Turbo conventional heat
- Full grill
- Eco grill
- Turbo grill
- Defrost
- Boost [rapid preheat]

OVEN FEATURES

- MotionHeat+ technology
- 67 Litre capacity
- Full touch control
- Self-cleaning catalytic liners [back and sides]

- Easy clean enamel interior
- Two internal lights
- Closed door grilling
- Easy to remove chrome shelf racks
- Double glazed door
- Full width inner door glass
- Tangential cooling fan

DESIGN

- Black square bar handle
- White LED display

ACCESSORIES

- 2 Safety-stop shelves
- 1 Grill pan with handle
- 2 Sets of full extension telescopic runners

OPTIONAL EXTRAS

- 1 Air fry tray [AIRFRY2]
- 1 Wire shelf [SHELF4]
- 1 Baking tray [TRAY3]
- 1 Pizza stone [PIZZASTONE]
- 1 Pizza peel [PIZZAPEEL]
- Pair of full extension telescopic runners [CAPRACK8]
- Metallic handles available [see p.190 for full range] Visit caple.co.uk for full range

INSTALLATION

- Diagram [p.216]
- Rated load 3.22kW
- Fuse rating 16A

SENSE ELECTRIC SINGLE OVEN

MotionHeat+



PRODUCT CODE

S C2362BG

DIMENSIONS

↔ w:600mm

PERFORMANCE

e Energy class A

FINISH AVAILABLE

■ Black Glass

FUNCTIONS

8 Functions

- Light
- Conventional heat
- Fan heat
- Full grill
- Eco grill
- Turbo grill
- Turbo base heat
- Defrost

OVEN FEATURES

- MotionHeat+ technology
- 67 Litre capacity
- Metal dial controls
- Self-cleaning catalytic liners [back and sides]
- Easy to clean enamel interior
- Two internal lights

- Closed door grilling
- Easy to remove chrome shelf racks
- Double glazed door
- Full width inner door glass
- Tangential cooling fan

DESIGN

- Black square bar handle
- White LED display

ACCESSORIES

- 2 Safety-stop shelves
- 1 Grill pan with handle
- 2 Sets of full extension telescopic runners

OPTIONAL EXTRAS

- 1 Air fry tray [AIRFRY2]
- 1 Wire shelf [SHELF4]
- 1 Baking tray [TRAY3]
- 1 Pizza stone [PIZZASTONE]
- 1 Pizza peel [PIZZAPEEL]
- Pair of full extension telescopic runners [CAPRACK8]
- Shelf end cover [SHELFCOV/SS and SHELFCOV/BK]
- Metallic handles available [see p.190 for full range] Visit caple.co.uk for full range

INSTALLATION

- Diagram [p.216]
- Rated load 3.22kW
- Fuse rating 16A

FUNCTIONS



FUNCTIONS



FUNCTIONS

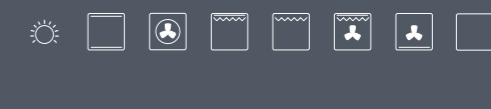

CLASSIC.

Our high-performance Classic range comes with a host of standard and optional features, designed to make cooking even more satisfying.

These ovens are classically designed, as the name suggests, in Stainless Steel and sheer Black Glass. Including features such as touch control timers, cool-touch doors plus a pyrolytic self-cleaning model.

C Look out for products marked with Classic flags to easily identify the range.

PERFECT HARMONY

The Classic range has been designed to seamlessly fit together to create a premium look. Whether you prefer a clean linear design or a practical stacked style, each model works perfectly together [see p.58 - 59].

TOUCH CONTROL OR SOLID METAL DIALS

You can preset cooking start and stop times with ease of use and precise control at your fingertips.



MotionHeat+ technology utilises specially designed vents and fan heat to evenly distribute hot air around the oven cavity. It reaches the desired temperature rapidly with no need to preheat, saving time & energy. Perfect for multi-level cooking without the transfer of flavours achieving even results every time.

LARGE VIEWING WINDOW WITH A LARGE CAPACITY TO MATCH

For more efficient cooking you can keep an eye on exactly what you're cooking without having to open the door and lose heat. Some single ovens also have a capacity as large as 67 litres, perfect for a hungriest of households.





CLASSIC ELECTRIC PYROLYTIC SINGLE OVEN



FEATURES

PYROLYTIC CLEANING

The Pyrolytic technology works by heating the oven to 475°C, causing even hidden & baked-on grime to carbonise into a fine ash. It saves you vast amounts of elbow grease, & actually improves oven efficiency over time too.

ELECTRONIC THERMOSTAT

For precise temperature control.

TELESCOPIC RUNNERS

The C2239 oven comes with two full extension telescopic runners making it easier to check food as it cooks and reducing the risk of burning yourself on the oven interior.

PRODUCT CODE

C C2239

DIMENSIONS

↔ w:600mm

PERFORMANCE

e Energy class A

FINISH AVAILABLE

Stainless Steel with Black Glass

FUNCTIONS

11 Functions

- Light
- Defrost
- Conventional heat
- Fan heat
- Eco grill
- Full grill
- Turbo grill
- Turbo base heat
- Turbo conventional heat
- Pyrolytic self-cleaning
- Boost [rapid preheat]

OVEN FEATURES

- MotionHeat+ technology
- 67 Litre capacity
- Electronic dial controls
- Easy to clean enamel interior

- Quadruple glazed door
- Door safety lock during pyrolytic function
- Internal light
- Closed door grilling
- Easy to remove chrome shelf racks
- Full width inner door glass
- Tangential cooling fan

DESIGN

- Stainless Steel square bar handle
- Green LED display

ACCESSORIES

- 1 Safety-stop shelf
- 1 Grill pan and rack with handle
- 2 Sets of full extension telescopic runners

OPTIONAL EXTRAS

- 1 Wire shelf [SHELF4]
 - 1 Baking tray [TRAY4]
 - 1 Pizza stone [PIZZASTONE]
 - 1 Pizza peel [PIZZAPEEL]
 - 1 Air fry tray [AIRFRY]
 - Pair of full extension telescopic runners [CAPRACK8]
- Visit caple.co.uk for full range

INSTALLATION

- Diagram [p.217]
- Rated load 3.57kW
- Fuse rating 16A



CLASSIC ELECTRIC SINGLE OVEN



PRODUCT CODE

C C2237

DIMENSIONS

↔ w:600mm

PERFORMANCE

e Energy class A

FINISH AVAILABLE

Stainless Steel with Black Glass

FUNCTIONS

9 Functions

- Light
- Defrost
- Conventional heat
- Fan heat
- Eco grill
- Full grill
- Turbo grill
- Turbo base heat
- Turbo conventional heat

OVEN FEATURES

- MotionHeat+ technology
- 67 Litre capacity
- Metal dial controls
- Easy to clean enamel interior
- Double glazed door

- Internal light
- Closed door grilling
- Easy to remove chrome shelf racks
- Full width inner door glass
- Tangential cooling fan

DESIGN

- Stainless Steel square bar handle
- Green LED display

ACCESSORIES

- 1 Safety-stop shelf
- 1 Grill pan and rack with handle

OPTIONAL EXTRAS

- 1 Wire shelf [SHELF4]
 - 1 Baking tray [TRAY3]
 - 1 Pizza stone [PIZZASTONE]
 - 1 Pizza peel [PIZZAPEEL]
 - 1 Air fry tray [AIRFRY]
 - Pair of full extension telescopic runners [CAPRACK8]
- Visit caple.co.uk for full range

INSTALLATION

- Diagram [p.217]
- Rated load 3.2kW
- Fuse rating 16A

FUNCTIONS



P BOOST

FUNCTIONS



CLASSIC ELECTRIC SINGLE OVENS



C2234



C2234BK

PRODUCT CODE

- C** Stainless Steel C2234
- C** Black Glass C2234BK

DIMENSIONS

w:600mm

PERFORMANCE

e Energy class A

FINISH AVAILABLE

- Stainless Steel with Black Glass
- Black Glass

FUNCTIONS

5 Functions

- Light
- Defrost
- Fan heat
- Full grill
- Turbo grill

OVEN FEATURES

- MotionHeat+ technology
- 67 Litre capacity
- Metal dial controls
- Easy to clean enamel interior
- Double glazed door
- Internal light
- Closed door grilling
- Easy to remove chrome shelf racks
- Full width inner door glass
- Tangential cooling fan

DESIGN

- Stainless Steel square bar handle
- Green LED display

ACCESSORIES

- 1 Safety-stop shelf
- 1 Grill pan and rack with handle

OPTIONAL EXTRAS

- 2 Black dials [CKNOB5BK - for C2234BK]
- 1 Wire shelf [SHELF4]
- 1 Baking tray [TRAY3]
- 1 Pizza stone [PIZZASTONE]
- 1 Pizza peel [PIZZAPEEL]
- 1 Air fry tray [AIRFRY]
- Pair of full extension telescopic runners [CAPRACK8]
Visit caple.co.uk for full range

INSTALLATION

- Diagram [p.217]
- Rated load 2.34kW
- Fuse rating 13A

FEATURES



LARGE VIEWING WINDOW WITH A LARGE CAPACITY TO MATCH

For more efficient cooking you can keep an eye on exactly what's in the oven without opening the door and losing heat.

FUNCTIONS



CLASSIC ELECTRIC SINGLE OVEN



PRODUCT CODE

C C2231

DIMENSIONS

w:600mm

PERFORMANCE

e Energy class A

FINISH AVAILABLE

- Stainless Steel with Black Glass

FUNCTIONS

5 Functions

- Light
- Defrost
- Fan heat
- Full grill
- Turbo grill

OVEN FEATURES

- MotionHeat+ technology
- 67 Litre capacity
- Audible minute minder
- Metal dial controls
- Easy to clean enamel interior
- Double glazed door
- Internal light

FUNCTIONS



CLASSIC SIDE OPENING ELECTRIC SINGLE OVEN



PRODUCT CODE

C C2220

DIMENSIONS

w:600mm

PERFORMANCE

e Energy class A

FINISH AVAILABLE

- Stainless Steel with Black Glass

FUNCTIONS

5 Functions

- Light
- Defrost
- Fan heat
- Full grill
- Turbo grill

OVEN FEATURES

- MotionHeat+ technology
- 67 Litre capacity
- Reversible door
- Metal dial controls
- Easy to clean enamel interior
- Double glazed door
- Internal light
- Closed door grilling
- Easy to remove chrome shelf racks
- Full width inner door glass
- Tangential cooling fan

FUNCTIONS



DESIGN

- Stainless Steel square bar handle
- Green LED display

ACCESSORIES

- 1 Safety-stop shelf
- 1 Grill pan and rack with handle

OPTIONAL EXTRAS

- 1 Wire shelf [SHELF4]
- 1 Baking tray [TRAY3]
- 1 Pizza stone [PIZZASTONE]
- 1 Pizza peel [PIZZAPEEL]
- 1 Air fry tray [AIRFRY]
- Pair of full extension telescopic runners [CAPRACK8]
Visit caple.co.uk for full range

INSTALLATION

- Diagram [p.217]
- Rated load 2.34kW
- Fuse rating 13A

FEATURES

SIDE OPENING DOOR

The side opening door allows for easy access inside the oven cavity without having to manoeuvre around the door. This means you can get closer to the oven which is handy when cleaning.



Double Ovens.

When mass catering is on the cards, Caple comes up trumps. Our Sense and Classic ranges offer the capacity and the functions you need to satisfy the largest appetites.

Look out for products marked with Sense and Classic flags to easily identify the ranges.

S C



SENSE ELECTRIC DOUBLE OVEN

MotionHeat+



PRODUCT CODE

S C3371BG

DIMENSIONS

↔ w:595mm

PERFORMANCE

e Top Oven A
Bottom Oven A

FINISH AVAILABLE

■ Black Glass

FUNCTIONS

4 Top Oven

- Conventional Heat
- Full Grill
- Base Heat
- Top Heat

8 Bottom Oven

- Light
- Turbo defrost
- Conventional heat
- Fan heat
- Eco grill
- Full grill
- Turbo grill
- Turbo base heat

OVEN FEATURES

Top Oven

- 40 Litre capacity

Bottom Oven

- 61 Litre capacity

GENERAL FEATURES

- MotionHeat+ technology
- Black metal dial controls
- Triple glazed doors with heat reflective glass
- Easy clean enamel interior
- Removable chrome shelf racks
- Catalytic liners in both oven cavities
- Tangential cooling fan

DESIGN

- Black square bar handle
- White LED display

ACCESSORIES

- 1 Safety stop shelf in top oven
- 1 Safety stop shelf in bottom oven
- 1 Grill pan with handle in top oven
- 1 Enamelled baking tray in bottom oven
- 2 Pairs of full extension telescopic runners

OPTIONAL EXTRAS

- 1 Air fry tray [AIRFRY2]
- 1 Wire shelf [SHELF3]
- 1 Pizza stone [PIZZASTONE]
- 1 Pizza peel [PIZZAPEEL]
- 1 set of full extension telescopic runners [CAPRACK8]

Visit caple.co.uk for full range

INSTALLATION

- Diagram [p.217]
- Rated load 5.19kW
- Fuse rating 32A

FUNCTIONS



Please note this product has not been designed to suit a quad or linear installation. See pages 58 - 59 for recommended combinations.



CLASSIC ELECTRIC DOUBLE OVEN

PRODUCT CODE

C C3249

DIMENSIONS

w:595mm

PERFORMANCE

e Top Oven A
Bottom Oven A

FINISH AVAILABLE

Stainless Steel with Black Glass

FUNCTIONS

4 Top Oven

- Conventional heat
- Full grill
- Base heat
- Top heat

8 Bottom Oven

- Light
- Turbo defrost
- Fan heat
- Turbo grill
- Conventional heat
- Turbo base heat
- Eco grill
- Full grill

OVEN FEATURES

Top Oven

- 40 Litre capacity

Bottom Oven

- 61 Litre capacity

GENERAL FEATURES

- Triple glazed doors with heat reflective glass
- Easy clean enamel interior
- Removable chrome shelf racks
- Tangential cooling fan

DESIGN

- Stainless Steel square bar handle
- Green LED display

ACCESSORIES

- 1 Safety-stop shelf in top oven
- 1 Safety-stop shelf in bottom oven
- 1 Grill pan with handle in top oven
- 1 Enamelled baking tray in bottom oven

OPTIONAL EXTRAS

- Spare shelf [SHELF3]
 - 1 Pizza stone [PIZZASTONE]
 - 1 Pizza peel [PIZZAPEEL]
 - 1 Air fry tray [AIRFRY]
 - Pair of telescopic runners [CAPRACK7]
- Visit caple.co.uk for full range

INSTALLATION

- Diagram [p.217]
- Rated load 5.19kW
- Fuse rating 32A



CLASSIC ELECTRIC DOUBLE OVEN

PRODUCT CODE

C C3246

DIMENSIONS

w:595mm

PERFORMANCE

e Top Oven A
Bottom Oven A

FINISH AVAILABLE

Stainless Steel and Black Glass

FUNCTIONS

4 Top Oven

- Conventional heat
- Full grill
- Base heat
- Top heat

4 Bottom Oven

- Light
- Turbo defrost
- Fan heat
- Turbo grill

OVEN FEATURES

Top Oven

- 40 Litre capacity

Bottom Oven

- 61 Litre capacity

GENERAL FEATURES

- Triple glazed doors with heat reflective glass
- Easy clean enamel interior
- Removable chrome shelf racks
- Tangential cooling fan

DESIGN

- Stainless Steel square bar handle
- Green LED display

ACCESSORIES

- 1 Safety-stop shelf in top oven
- 1 Safety-stop shelf in bottom oven
- 1 Grill pan with handle in top oven
- 1 Enamelled baking tray in bottom oven

OPTIONAL EXTRAS

- Spare shelf [SHELF3]
 - 1 Pizza stone [PIZZASTONE]
 - 1 Pizza peel [PIZZAPEEL]
 - 1 Air fry tray [AIRFRY]
 - Pair of telescopic runners [CAPRACK7]
- Visit caple.co.uk for full range

INSTALLATION

- Diagram [p.217]
- Rated load 5.19kW
- Fuse rating 32A

FEATURES

OVEN DOORS

The triple glazed doors with heat reflective glass and full width sealed inner door glass makes these oven doors perfect for those looking to entertain regularly.



LED TOUCH CONTROL

The C3249 intuitive control lets you swiftly access all functions, the electronic cooking timer, end time, minute minder and clock.



FUNCTIONS



FUNCTIONS



Built-under Oven.



Neat, versatile and with a host of clever design features, our built-under ovens fit perfectly beneath the worktop.

Grill in the top oven whilst fan cooking in the bottom - the ultimate tool in multi-tasking cooking.

CLASSIC ELECTRIC BUILT-UNDER OVEN



PRODUCT CODE

C C4246

DIMENSIONS

← w:595mm

PERFORMANCE

e Top Oven A
Bottom Oven A+

FINISH AVAILABLE

■ Stainless Steel and Black Glass

FUNCTIONS

4 Top Oven

- Conventional heat
- Full grill
- Base heat
- Top heat

8 Bottom Oven

- Light
- Turbo defrost
- Fan heat
- Conventional heat
- Turbo base heat
- Base heat
- Top heat
- Turbo conventional heat

OVEN FEATURES

Top Oven

- 40 Litre capacity

Bottom Oven

- 42 Litre capacity

GENERAL FEATURES

- Triple glazed doors with heat reflective glass
- Easy clean enamel interior
- Removable chrome shelf racks
- Tangential cooling fan

DESIGN

- Stainless Steel square bar handle
- Green LED display

ACCESSORIES

- 1 Safety-stop shelf in top oven
- 1 Safety-stop shelf in bottom oven
- 1 Grill pan with handle
- 1 Enamelled baking tray

OPTIONAL EXTRAS

- Spare shelf [SHELF3]
 - 1 Pizza stone [PIZZASTONE]
 - 1 Pizza peel [PIZZAPEEL]
 - 1 Air fry tray [AIRFRY]
 - Pair of telescopic runners [CAPRACK7]
- Visit caple.co.uk for full range

INSTALLATION

- Diagram [p.217]
- Rated load 4.7kW
- Fuse rating 20A

FUNCTIONS



Microwaves + Steam Ovens.

Can't choose between the two? Why not opt for a combination microwave and steam oven.

A must-have for a busy lifestyle.



Combination Microwave + Steam.

Versatility is key with our innovative combination steam microwave.

This revolutionary, built-in appliance enables you to steam, grill, bake and microwave your food simply. It combines all the health benefits of steam cooking with the power and speed of a microwave.



SENSE PREMIUM BUILT-IN COMBINATION MICROWAVE AND STEAM



CMS260BG



CMS260BS



CMS260GM



CMS260SS

PRODUCT CODE

- sp** Black Glass CMS260BG
- sp** Black Steel CMS260BS
- sp** Gunmetal CMS260GM
- sp** Stainless Steel CMS260SS

DIMENSIONS

- h:450mm

FINISH AVAILABLE

- Black Glass
- Black Steel
- Gunmetal with Black Glass
- Stainless Steel with Black Glass

FUNCTIONS

15 Functions

- Light
- Defrost
- Fan heat
- Full grill
- Turbo grill
- Microwave
- Microwave + fan heat
- Microwave + turbo grill
- Microwave + steam
- Steam
- Turbo grill + steam
- Grill + steam
- Fan heat + steam
- Descale
- Steam+

FEATURES

- WiFi connectivity
- Compatible with CapleHome App
- CapleTouch+ TFT Touch control
- Programmable timer
- Favourites: Save your preferred cooking settings
- Multi-stage cooking
- 40 litre capacity
- Double glazed door
- Turntable free design
- Internal light
- Child safety lock
- Adjustable microwave power levels
- Digital / Analogue clock
- Adjustable display brightness
- Minute minder
- Closed door grilling
- Tangential cooling fan
- Night mode
- Demo mode
- AutoTime [counts up]
- Chrome shelf racks with 3 positions

DESIGN

- Black square bar handle [CMS260BG, CMS260BS and CMS260GM]
- Stainless Steel bar handle [CMS260SS]
- Stainless Steel interior
- Colour display

ACCESSORIES

- 1 Grill rack for glass tray
- 1 Steam tray
- 1 Safety-stop shelf
- 1 Glass tray
- 1 Glass base plate

OPTIONAL EXTRAS

- Shelf end cover [SHELFCOV/SS and SHELFCOV/BK]
- Metallic handles available [see p.190 for full range]
- Visit caple.co.uk for full range

COOKING OUTPUT

- Microwave 1000W

INSTALLATION

- Diagram [p.218]
- Rated load 3.05kW
- Fuse rating 16A

Features + Functions

CAPLETOUCH+

The Sense Premium cooking range features CapleTouch+ display. Saving your family favourites, setting multi-stage cooking timers, it couldn't be easier with the intuitive interface.

STEAM +

Set the oven to inject steam at specified intervals into the oven cavity during cooking to achieve restaurant quality results in your home.

IOS



ANDROID



Scan the QR Codes to access the 'How to guides' videos.'

FEATURES



WIFI CONNECTIVITY

The Sense Premium cooking range features WiFi connectivity.



CAPLE HOME

Download the Caple Home app available on Android or iOS.

MULTI-STAGE COOKING

Some dishes require multiple functions at different stages of cooking. Multi-stage cooking does this for you without the fuss then allows you to save the setting to your favourites to ensure perfect results every time.

FAVOURITES

Save your family favourites, multi-stage cooking settings, it couldn't be easier with the intuitive interface.

FUNCTIONS





Combination Steam Cooking.

Steam cooking is especially well suited to cooking foods like seafood, bread, vegetables, pasta and rice - the sky's the limit.

Utilising the combined functions of a steam oven - fan, steam, and grill - you can be sure to beautifully capture flavour at every turn. From delicate fish and perfectly baked bread to cooking succulent joints of meat with fan and steam to lock in moisture, combination cooking has never been so easy.

TOUCH CONTROLS + LCD DISPLAY

The intuitive full touch control panel lets you swiftly access all functions, as well as the programmable electronic timer and electronic clock. You can also view the current cooking time and the actual temperature in the cavity.

DELICIOUS DESSERTS

Combining fan heat [dry heat] with steam [moisture] is the optimum environment for making perfect light pastry or cakes.

ODOURLESS COOKING

There are no food odours with steam. This means you can prepare different parts of a meal together, without the flavours mingling. You can save energy too by cooking your meat and vegetables together.

LARGE VIEWING WINDOW

From the display panel select the light function to check what is cooking without steam escaping the cavity.

SENSE BUILT-IN COMBINATION STEAM OVENS



SO111GM



SO111SS

PRODUCT CODE

S	Gunmetal	SO111GM
S	Stainless Steel	SO111SS

DIMENSIONS

h:450mm

PERFORMANCE

e	Energy class A+
---	-----------------

FINISH AVAILABLE

■	Gunmetal and Black Glass
■	Stainless Steel and Black Glass

FUNCTIONS

11 Functions

- Light
- Defrost
- Fan heat
- Full grill
- Turbo grill
- Grill and steam
- Steam
- Turbo grill and steam
- Fan heat with steam
- Descale
- Boost [rapid preheat]

OVEN FEATURES

- 40 Litre capacity
- Full touch control
- Auto water tank in control panel
- Programmable electronic timer
- Electronic clock
- Moulded shelf supports
- Internal light
- Double glazed removable door
- Descaling programme
- Steam cooking 40 - 100°C

DESIGN

- Black square bar handle [SO111GM]
- Stainless Steel square bar handle [SO111SS]
- Stainless Steel interior
- White display

ACCESSORIES

- 1 Shelf
- 1 Grill pan and handle
- 1 Steam tray

OPTIONAL EXTRAS

- 1 Descaler liquid [DESCALER]
- Visit caple.co.uk for full range

INSTALLATION

- Diagram [p.218]
- Rated load 3.05kW
- Fuse rating 16A

FEATURES

EASY CLEAN STAINLESS STEEL INTERIOR

The beautiful Stainless Steel interior means the cavity can simply be wiped clean after every use.

EASILY ACCESSIBLE WATER TANK

The water tank is conveniently located within the control panel and automatically open at the touch of a button.



FUNCTIONS



Meals in Minutes.

Minimalist design to complement any kitchen, yet big on handy features.

Depending on your cooking requirements, you can choose a microwave for its traditional uses such as warming up leftovers or defrosting food quickly. Alternatively, why not opt for a combination microwave? As well as cooking meals quickly, you can also use it as a normal oven and grill providing extra space when you are entertaining.



SENSE MICROWAVES

If you are in need of a traditional microwave to heat up your leftovers, then one of the built-in microwaves is the perfect choice. Or, if you are looking for an extension of your oven, opt for a combination microwave with a fan oven and powerful grill.

TURNTABLE FREE DESIGN

Caple microwaves have been designed to look the part. Some models have 40L capacity, removable dishwasher-friendly glass base and a turntable free design. This means you can fit large dishes into the cavity.

CLASSIC MICROWAVES

Want to create a seamless built-in look? The Classic range allows you to neatly arrange the bank of appliances in a linear or stacked formation so you can match your oven and microwave perfectly.

Look out for products marked with a Sense or Classic flag to easily identify the ranges.



SENSE BUILT-IN COMBINATION MICROWAVES



CM111BG



CM111GM



CM111SS

PRODUCT CODE

- S** Black Glass CM111BG
- S** Gunmetal CM111GM
- S** Stainless Steel CM111SS

DIMENSIONS

- h:450mm

FINISH AVAILABLE

- Black Glass
- Gunmetal and Black Glass
- Stainless Steel and Black Glass

FUNCTIONS

- 10** Functions
- Light
- Microwave [10 power levels]
- Auto Defrost
- Turbo Grill
- Fan heat
- Turbo conventional
- Microwave and fan heat
- Microwave and turbo grill
- Microwave and conventional heat
- Auto cooking

FEATURES

- 40 Litre capacity
- Full touch control
- Electronic clock
- Turntable free design
- Chrome shelf rack with 3 positions
- Internal light
- Double glazed removable door
- Child safety lock
- 8 Auto cooking programmes
- Auto-defrost

AUTO COOKING PROGRAMMES

- Milk
- Soup
- Vegetables
- Noodles
- Bread
- Fish
- Meat
- Chicken

DESIGN

- Black square bar handle [CM111BG and CM111GM]
- Stainless Steel square bar handle [CM111SS]
- Stainless Steel interior
- White LED display

ACCESSORIES

- 1 Shelf
- 1 Baking tray
- 1 Glass base plate

OPTIONAL EXTRAS

- Shelf end cover [SHELFCOV/SS and SHELFCOV/BK]

Visit caple.co.uk for full range

COOKING OUTPUT

- Microwave 1000W

INSTALLATION

- Diagram [p.218]
- Rated load 2.55kW
- Fuse rating 13A

FEATURES

CONVECTION COOKING

Bringing together a ring element and a fan to provide evenly cooked and browned results. It's quicker than conventional cooking and can be combined with the microwave to reduce cooking time even more, the grill for perfect browning or both the microwave and grill together.

TURBO GRILL

The fan cooking system and grill deliver perfect results in all kinds of meals. It even locks in meat juices for better flavour.

FUNCTIONS





SENSE BUILT-IN MICROWAVE



COMPLETELY SEAMLESS

Complete your kitchen's sleek look with shelf end covers. Seamlessly blend cabinets and appliances to create a professional and cohesive finish by adding this final detail [see above].



PRODUCT CODE

S CM1081BG

DIMENSIONS

h:450mm

FINISH AVAILABLE

Black Glass

FUNCTIONS

4 Functions

- Light
- Microwave [10 power levels]
- Auto defrost
- Auto cooking

FEATURES

- 40 Litre capacity
- Full touch control
- Programmable electronic timer
- Digital clock
- Turntable free design
- Internal light
- Double glazed door
- 10 power levels
- Child safety lock
- Auto-defrost
- 8 Auto cooking programmes

AUTO COOKING PROGRAMMES

- Milk
- Soup
- Vegetables
- Noodles
- Bread
- Fish
- Meat
- Chicken

DESIGN

- Black square bar handle
- Stainless Steel interior
- White LED display

ACCESSORIES

- 1 Glass base plate

OPTIONAL EXTRAS

- Shelf end cover [SHELFCOV/SS and SHELFCOV/BK]
- Visit caple.co.uk for full range

COOKING OUTPUT

- Microwave 1000W

INSTALLATION

- Diagram [p.218]
- Rated load 1.5kW
- Fuse rating 10A

FUNCTIONS



AUTO

CLASSIC BUILT-IN MICROWAVES



CM108SS



CM108BK

PRODUCT CODE

C Stainless Steel CM108SS

C Black Glass CM108BK

DIMENSIONS

h:450mm

FINISH AVAILABLE

Stainless Steel and Black Glass

Black Glass

FUNCTIONS

4 Functions

- Light
- Microwave [10 power levels]
- Auto Defrost
- Auto cooking

FEATURES

- 40 Litre capacity
- Full touch control
- Electronic clock
- Turntable free design
- Internal light
- Double glazed removable door
- [Microwave] 10 power levels
- Child safety lock

- 8 Auto cooking programmes
- Auto-defrost

AUTO COOKING PROGRAMMES

- Milk
- Soup
- Vegetables
- Noodles
- Bread
- Fish
- Meat
- Chicken

DESIGN

- Stainless Steel square bar handle
- Stainless Steel interior
- Green LED display

ACCESSORIES

- 1 Glass base plate

COOKING OUTPUT

- Microwave 1000W

INSTALLATION

- Diagram [p.218]
- Rated load 1.5kW
- Fuse rating 10A

CLASSIC BUILT-IN COMBINATION MICROWAVE



PRODUCT CODE

C CM126

DIMENSIONS

h:460mm [inc. built-in frame]

FINISH AVAILABLE

Fingerprint resistant Stainless Steel

FEATURES

- 25 Litre capacity
- Auto cooking
- Auto defrost
- Speed cooking
- Multi-stage cooking
- Child safety lock
- Minute minder [up to 95mins]
- End of cooking signal
- Push door

DESIGN

- Stainless Steel front and cavity
- Mark resistant finish
- Green LED display

COOKING OUTPUT

- Microwave 900W
- Grill 1000W
- Convection 2500W

INSTALLATION

- Diagram [p.218]
- Rated load 2.5kW
- Fuse rating 13A

FUNCTIONS



AUTO

CLASSIC BUILT-IN MICROWAVE AND GRILL



CM123



CM123BK

PRODUCT CODE

C CM123

C CM123BK

DIMENSIONS

 h:460mm
[inc. built-in frame]

FINISH AVAILABLE

 Fingerprint resistant
Stainless Steel

 Black Glass

FEATURES

- 25 Litre capacity
- Auto cooking
- Auto defrost
- Speed cooking
- Multi-stage cooking
- Child safety lock
- Minute minder [up to 95mins]
- End of cooking signal
- Push door

DESIGN

- Stainless Steel front and cavity
- Mark resistant finish
- Green LED display

COOKING OUTPUT

- Microwave 900W
- Grill 1000W

INSTALLATION

- Diagram [p.218]
- Rated load 1.45kW
- Fuse rating 13A

CLASSIC BUILT-IN WALL UNIT MICROWAVE AND GRILL



PRODUCT CODE

C CM121BK

DIMENSIONS

 h:382mm
[inc. built-in frame]

FINISH AVAILABLE

 Black

FEATURES

- 17 Litre capacity
- Auto cooking
- Auto defrost
- Multi-stage cooking
- Child safety lock
- Minute minder [up to 95mins]
- Closed door grilling

DESIGN

- Stainless Steel cavity
- Green LED display

ACCESSORIES

- Glass base plate
- Freestanding grill rack

COOKING OUTPUT

- Microwave 700W
- Grill 1000W

INSTALLATION

- Diagram [p.219]
- Rated load 1.1kW
- Fuse rating 13A

CLASSIC BUILT-IN MICROWAVE AND GRILL



PRODUCT CODE

C CM130

DIMENSIONS

 h:388mm
[inc. built-in frame]

FINISH AVAILABLE

 Fingerprint resistant
Stainless Steel

FEATURES

- 25 Litre capacity
- Microwave and grill combined cooking
- Auto Cooking
- Defrost by time or weight
- Speed cooking
- Multi stage cooking
- Child safety lock

- Minute minder [up to 95mins]
- End of cooking signal
- Push door
- Trim kit and unit installed in packaging

DESIGN

- Stainless Steel front and cavity
- Mark resistant finish
- Green LED display

COOKING OUTPUT

- Microwave 900W
- Grill 1000W

INSTALLATION

- Diagram [p.218]
- Rated load 2.15kW
- Fuse rating 13A

CLASSIC BUILT-IN WALL UNIT MICROWAVE AND GRILL



PRODUCT CODE

C CM120

DIMENSIONS

 h:382mm
[inc. built-in frame]

FINISH AVAILABLE

 Fingerprint resistant
Stainless Steel

FEATURES

- For building into a 300mm deep wall cabinet
- 17 Litre capacity
- Auto cooking
- Auto defrost
- Speed cooking
- Multi-stage cooking
- Child safety lock
- Minute minder [up to 95mins]
- End of cooking signal
- Push door

DESIGN

- Stainless Steel cavity
- Mark resistant finish
- Green LED display

ACCESSORIES

- Glass base plate
- Freestanding grill rack

COOKING OUTPUT

- Microwave 700W
- Grill 1000W

INSTALLATION

- Diagram [p.219]
- Rated load 1.05kW
- Fuse rating 13A

Coffee Machines.

Combining the subtle art of the barista with the very latest in coffee machine technology.

Caple gives you perfect coffee at the touch of a button.





The Secret to Great Coffee.

Fantastic coffee depends on many factors. The beans you use, the way they're ground, even what temperature it is and how it is frothed. Plus, of course, finding a coffee machine that's really up to the job.

BARISTA STYLE COFFEE

If you like milk with your coffee, you'll also need to polish up your frothing skills. The texture depends on how the air enters the milk as you steam. You need a smooth, consistent texture where the foam and milk intertwine. Look out for blobs of froth on top, and don't boil it. If the jug's base is too hot to touch, it means the milk's probably reached the right temperature.

For barista style lattes, cappuccinos and flat whites at the touch of a button.

MAKING A PERFECT ESPRESSO

What you're aiming for is a pour that starts out darkly coloured then turns into shades of caramel moving slowly, like honey. Caple coffee machines makes it effortless every time.

BUILT-IN COFFEE MACHINES



CM465BG



CM465BS



CM465GM



CM465SS

PRODUCT CODE

Black Glass	CM465BG
Black Steel	CM465BS
Gunmetal	CM465GM
Stainless Steel	CM465SS

DIMENSIONS

h:450mm

FINISH AVAILABLE

- Black Glass
- Black Steel
- Gunmetal and Black Glass
- Stainless Steel and Black Glass

FEATURES

- Fully automatic
- Full touch control with white LCD display
- Settings can be adjusted for making various hot drinks such as short espresso, long espresso, normal coffee, long coffee, warm milk, warm water or cappuccino [Milk/coffee mix can be customised]
- Coffee bean grinder
- Coffee grinder adjustment to modify how fine the coffee beans are ground [13 settings]
- Uses fresh coffee beans or pre-ground coffee
- 5 Drink volume adjustments to modify the amount of coffee dispensed [Espresso, small, medium, large, mug]. Each size can be adjusted to fit your favourite cup.

- 30 Auto programmes
- Programme machine to switch-on and warm up at set time
- Makes 2 cups at a time
- Milk jug
- Steam nozzle to heat and froth milk
- Hot water function
- 3 temperature settings
- 5 Coffee strength settings [Extra-strong, strong, medium, light, extra-light]
- 1.8 Litre water tank
- 200g coffee bean capacity
- 15 bar steam pressure
- Drip tray, to collect spillages
- Used coffee ground bin
- Stand-by energy saving
- Water hardness setting
- Cleaning warning
- Descale programme

ACCESSORIES

- Coffee spoon
- Descaling agent bottle
- Milk jug
- Hot water nozzle

OPTIONAL EXTRAS

- 1 Liquid descaler [DESCALER]
Visit caple.co.uk for full range

INSTALLATION

- Diagram [p.219]
- Rated load 1.35kW
- Fuse rating 10A

FEATURES

CAPPUCCINO, JUST THE WAY YOU LIKE IT

Using the milk dispenser you can make your perfect flat white, latte or cappuccino. For ease of use the coffee machine is set to deliver a standard cappuccino, although if you prefer more or less coffee you can adjust either to suit your preference.

SEAMLESS INTEGRATION

Our coffee machines have been designed to work with Sense or Sense Premium range, so you can create your perfect combination.

COMPLETE CONTROL

Produce your ideal beverage with ease by adjusting the settings to your preference. You can control everything from the size and strength to the fineness of your coffee grind. Perfection every time.

Warming + Storage Drawers.

There's nothing more disappointing than a hot meal served on a cool plate. Caple's warming drawers keep tableware at just the right temperature for when the food is ready to be served.

Why not add a storage drawer too? It's a convenient and stylish way to organise your coffee and wine accessories.





WD290BG



WD290GM



WD290SS

WARMING DRAWERS

PRODUCT CODE

Black Glass	WD290BG
Gunmetal	WD290GM
Stainless Steel	WD290SS

DIMENSIONS

h:290mm

FINISH AVAILABLE

- Black Glass
- Gunmetal
- Stainless Steel

FEATURES

- Fan heating
- Handle opening
- Dishes for a meal for 6 people take approx 30mins to heat up to 75°C
- Maximum capacity 25kg
- 400W heating element with tangential fan
- 30 - 75°C adjustable thermostat
- Smooth slide soft-close drawer runners
- Non-slip base cover
- On/off light

INSTALLATION

- Diagram [p.219]
- Rated load 0.46kW
- Fuse rating 3A

FEATURES



QUALITY INTERIOR

Precision engineered sliding runners give a high-quality feel. All models feature either a protective anti-slip mat or stylish Black base.

WARMING DRAWERS

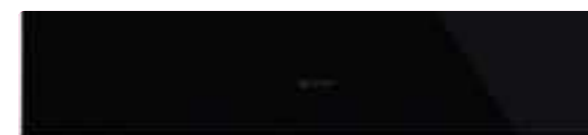

WD140BG



WD140BS



WD140GM



WD140SS

PRODUCT CODE

Black Glass	WD140BG
Black Steel	WD140BS
Gunmetal	WD140GM
Stainless Steel	WD140SS

DIMENSIONS

h:140mm

FINISH AVAILABLE

- Black Glass
- Black Steel
- Gunmetal
- Stainless Steel

FEATURES

- Fan heating
- Push/pull opening
- Dishes for a meal for 6 people take approx 30mins to heat up to 75°C
- Extremely rigid to support the weight of an appliance on top
- Maximum capacity 25kg
- 400W heating element with tangential fan
- 30 - 75°C adjustable thermostat
- Smooth slide drawer runners
- Non-slip base cover
- On/off light

INSTALLATION

- Diagram [p.219]
- Rated load 0.46kW
- Fuse rating 3A

WARMING DRAWERS

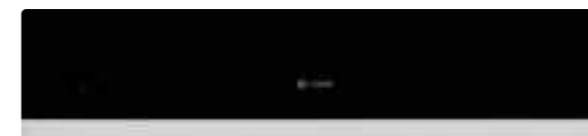

WD140CLSS

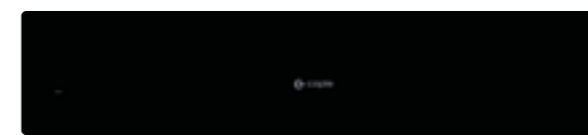

WD140CLBK

PRODUCT CODE

Black Glass & Stainless Steel	WD140CLSS
Black Glass	WD140CLBK

DIMENSIONS

h:140mm

FINISH AVAILABLE

- Black Glass and Stainless Steel
- Black Glass

FEATURES

- Fan heating
- Push/pull opening
- Dishes for a meal for 6 people take approx 30mins to heat up to 75°C
- Extremely rigid to support the weight of an appliance on top
- Maximum capacity 25kg
- 400W heating element with tangential fan
- 30 - 75°C adjustable thermostat
- Smooth slide soft-close drawer runners
- Non-slip base cover
- On/off light

INSTALLATION

- Diagram [p.219]
- Rated load 0.46kW
- Fuse rating 3A

STORAGE DRAWER



PRODUCT CODE

SD140BG

DIMENSIONS

h:140mm

FINISH AVAILABLE

- Black Glass

FEATURES

- Push/pull opening
- Extremely rigid to support the weight of an appliance on top
- Maximum capacity 25kg
- Smooth slide soft-close drawer runners
- Non-slip base cover

INSTALLATION

- Diagram [p.219]

Recommended Combinations.

All our compact appliances are designed to work with a matching oven. So when thinking about your kitchen design it is important to find the right combination for your needs.

Whether you prefer a clean linear design or a practical stacked style, each model works perfectly together. Choose from our Sense Premium, Sense or Classic range for a style to suit you.

sp SENSE PREMIUM STEEL



C2600SS ELECTRIC SINGLE PYROLYTIC OVEN | CMS260SS MICROWAVE + STEAM WD140SS WARMING DRAWER | CM465SS COFFEE MACHINE WD140SS WARMING DRAWER | WC6100SS IN-COLUMN WINE CABINET

sp SENSE PREMIUM BLACK GLASS



C2601BG ELECTRIC SINGLE PYROLYTIC OVEN | CMS260BG MICROWAVE + STEAM WD140BG WARMING DRAWER | CM465BG COFFEE MACHINE WD140BG WARMING DRAWER | WC6100BG IN-COLUMN WINE CABINET

sp SENSE PREMIUM GUNMETAL



C2601GM ELECTRIC SINGLE PYROLYTIC OVEN | CMS260GM MICROWAVE + STEAM WD140GM WARMING DRAWER | CM465GM COFFEE MACHINE WD140GM WARMING DRAWER | WC6100GM IN-COLUMN WINE CABINET

sp SENSE PREMIUM BLACK STEEL



C2601BS ELECTRIC SINGLE PYROLYTIC OVEN | CMS260BS MICROWAVE + STEAM WD140BS WARMING DRAWER | CM465BS COFFEE MACHINE WD140BS WARMING DRAWER | WC6100BS IN-COLUMN WINE CABINET

S SENSE STEEL



C2402SS ELECTRIC SINGLE PYROLYTIC OVEN | C2105SS ELECTRIC SOFT CLOSE SINGLE OVEN | CM111SS COMBI MICROWAVE WD140SS WARMING DRAWER | SO111SS STEAM OVEN WD140SS WARMING DRAWER | CM465SS COFFEE MACHINE WD140SS WARMING DRAWER | WC6100SS IN-COLUMN WINE CABINET

S SENSE GUNMETAL



C2403GM ELECTRIC SINGLE PYROLYTIC OVEN | C2106GM ELECTRIC SOFT CLOSE SINGLE OVEN | CM111GM COMBI MICROWAVE WD140GM WARMING DRAWER | SO111GM STEAM OVEN WD140GM WARMING DRAWER | CM465GM COFFEE MACHINE WD140GM WARMING DRAWER | WC6100GM IN-COLUMN WINE CABINET

S SENSE BLACK GLASS



C2403BG ELECTRIC SINGLE PYROLYTIC OVEN | C2106BG ELECTRIC SOFT CLOSE SINGLE OVEN | C2101BG ELECTRIC SINGLE OVEN | C2362BG ELECTRIC SINGLE OVEN | WC6100BG IN-COLUMN WINE CABINET



CM111BG COMBI MICROWAVE WD140BG WARMING DRAWER | CM1081BG MICROWAVE WD140BG WARMING DRAWER | CM465BG COFFEE MACHINE WD140BG WARMING DRAWER

COMPLETELY SEAMLESS

Complete your kitchen's sleek look with shelf end covers, designed to work with any Caple 60cm oven. Seamlessly blend cabinets and appliances to create a professional and cohesive finish by adding this final detail.



C CLASSIC



C2239 ELECTRIC SINGLE PYROLYTIC OVEN | C2237 ELECTRIC SINGLE OVEN | C2234 ELECTRIC SINGLE OVEN | C2234BK ELECTRIC SINGLE OVEN | CM1085S MICROWAVE WD140CLS WARMING DRAWER | CM108BK MICROWAVE WD140CLBK WARMING DRAWER



INSTALLATION TIP:

We recommend that when installing a stack or quad of products, a pair of our installation brackets [OVEN/BRACKETS2] are purchased to support the upper product ensuring a seamless fit.

Hobs.

Whether you choose gas, electric or induction, Caple's advanced technology and unswerving eye for detail means real control and stylish good looks every time.



Choosing the Right Hob.

INDUCTION

Uses leading-edge technology by creating a magnetic field between the hob and pan. They're quick, easy to use and energy efficient, vastly becoming a popular choice for professional chefs. [Find out more on p.64].



GAS

Heat is instant and the control is intuitive. You can choose either Stainless Steel or glass finishes. [Find out more on p.74].



ELECTRIC

The smooth glass finish of a electric ceramic hob makes cleaning easier. They're sleek and look very contemporary, making them ideal for more modern kitchens. [Find out more on p.71].



MIX + MATCH MODULAR HOBS

Any number of modules can be mixed together in any sequence. In fact, the options are almost endless. [Find out more on p.83].

Induction Hobs.

They're hygienic, more energy-efficient, safer and easy to use.

They work by creating a magnetic field between the hob and the pan. Heat is instant, and it's easy to control. Once you remove the pan, they cool down very quickly, which is handy if kids are about. They're more energy-efficient because they only heat the pan area itself, rather than all around it. In fact, they use around 25% less energy than some hobs.



MEMORY RECALL

After switching the hob off, it is possible to recall the last used settings with a couple of simple button presses.

AUTOMATIC PAN DETECTION

This feature detects when a suitable pan has been placed on a cooking zone, helping to eliminate the possibility of the hob being activated by a non-suitable object.

BOOSTER AND BOOSTER+

Saves time by increasing power for a quicker boiling time. Booster+ provides even further power and performance.

PAUSE FUNCTION

Temporarily stop all the active zones, then restart them with the same settings you paused it on.

BRIDGE FUNCTION

Want complete flexibility when cooking? Why not try an induction hob that can bridge two zones. If you cook regularly using oversized pans, these hobs will handle them with ease.

ANTI-OVERFLOW, BOIL CONTROL + ANTI-OVERHEAT

Anti-overflow automatically cuts-off the cooking zone if liquid boils over onto the control panel. Luckily boil control maintains a temperature of 94°C, just below boiling, whilst anti-overheat prevents the hob from overheating and damaging the elements, preserving the lifetime of your appliance.



SENSE PREMIUM FULL SURFACE ZONELESS INDUCTION HOB

PRODUCT CODE

sp C990i

DIMENSIONS

w:920mm

FINISH AVAILABLE

Black Glass

FEATURES

- 21 Total power levels [1-9 with 1/2 levels, Bake 42°C, keep warm 70°C, boil control 94°C, Booster and Booster+]
- Frameless with bevelled edge
- Touch control with full colour 7" TFT screen
- Booster function for up to 6 pans
- Heating area and delivered powers automatically adapts to the pan size
- Zoneless cooking
- 6 Programmable timers to set cooking duration and finishing time on each individual zone [up to 99 mins]
- User programmable power levels

- Memory recall function
- Pause function
- Child lock
- Residual heat indicators
- Automatic safety shut-off
- Automatic pan detection
- Automatic pan move
- Anti-overheat
- Anti-overflow
- Demo mode
- Individual zone timer
- Heating area and delivered power automatically adapts to the pan size

COOKING OUTPUT

Full Service Area Cooking

- Up to 6 Individual pans in use at once - 3.7kW

OPTIONAL EXTRAS

- Cast iron induction griddle [iGRIDDLE3]

INSTALLATION

- Diagram [p.220]
- Rated load 11.1kW
- Fuse rating 40A
- Voltage 220-240V

FEATURES



TFT TOUCH SCREEN

The TFT touch screen allows you to easily select cooking options through a seamless full colour display.



PAN MOVE

Pan move allows you to move the pan from one area to another taking all settings to the new location.



BOOSTER

Saves time by increasing power for a quicker boiling time. Available across all zones.



AUTO BRIDGE FUNCTION

Auto bridge function to link zones for larger pans.

RIBBON INDUCTION HOB



FEATURES

BOOSTER AND BOOSTER+

Saves time by increasing power for a quicker boiling time. Booster+ provides even further powers and performance.

PRODUCT CODE

C876i

DIMENSIONS

w:900mm

FINISH AVAILABLE

Black Glass

FEATURES

- Frameless
- Central slider touch control with direct access
- White display
- Can be flush mounted or inset
- 11 Level digital power display for each zone [0-9, keep warm 70°C, and Booster]
- Booster function on 2 zones
- Bridge function to create 1 large zone [from 2 zones]
- Programmable timer to set cooking duration and finishing time on each individual zone [up to 99 mins]

- Memory recall function
- Pause function
- Child lock
- Residual heat indicators
- Automatic safety shut-off
- Automatic pan detection
- Anti-overheat
- Anti-overflow

COOKING OUTPUT

4 Induction Zones

- 220mm - 3.0kW
- 190mm - 2.0kW
- 190mm - 1.4kW
- 175mm - 1.4kW

OPTIONAL EXTRAS

- Cast iron induction griddle [iGRIDDLE3]

INSTALLATION

- Diagram [p.220]
- Rated load 7.1kW
- Fuse rating 25A

INDUCTION HOB



FEATURES

BRIDGEABLE ZONES

The C897i zones provide complete flexibility in allowing either use of 5 individual zones, or the option to combine the 2 left hand zones and 2 right hand zones into larger zones for use with oversized pans or fish kettles.

PRODUCT CODE

C897i

DIMENSIONS

w:900mm

FINISH AVAILABLE

Black Glass

FEATURES

- Frameless
- Slider touch control with direct access
- 10 Level digital power display for each zone [0-9 plus Booster]
- Minute minder
- Programmable timer for each zone to set finish time [up to 99 mins]
- Child lock
- Bridgeable zones [left and right-hand side]

- Booster function on each zone
- Residual heat indicators
- Automatic safety shut-off
- Automatic pan detection
- Anti-overheat
- Anti-overflow

COOKING OUTPUT

5 Induction Zones

- 4 Dia. 180mm – 2.3kW
- 1 Dia. 280mm – 3.0kW

OPTIONAL EXTRAS

- Cast iron induction griddle [iGRIDDLE3]

INSTALLATION

- Diagram [p.220]
- Rated load 9.4kW
- Fuse rating 25A

INDUCTION HOB



FEATURES

PAN MOVE FUNCTION

Allows you to move the pan from one zone to another and it will automatically pick up the selected settings from the zone the pan has been moved from [power level and timer].

CHEF MODE

The chef mode creates three large zones, allowing you to cook with multiple pans at various temperatures all at the same time. For example, you can fry with intense heat then slide the pan over to a low temperature zone to keep it warm whilst you concentrate on other dishes.

PRODUCT CODE

C901i

DIMENSIONS

w:880mm

FINISH AVAILABLE

Black Glass

FEATURES

- Frameless
- Invisi touch control with direct access
- White display
- Can be flush mounted or inset
- 11 Level digital power display for each zone [0-9, keep warm 70°C and Booster]
- Booster function on each zone
- Programmable timer to set cooking duration and finishing time on each individual zone [up to 99 mins]
- Minute minder
- Automatic cooking duration display
- Memory recall function
- Chef mode

- Pan move function
- Pause function
- Demo mode
- Child lock
- Residual heat indicators
- Automatic safety shut-off
- Automatic pan detection
- Anti-overheat
- Anti-overflow

COOKING OUTPUT

5 Induction Zones

- 1 Dia. 160mm – 1.4kW
- 1 Dia. 180mm – 1.4kW
- 1 Dia. 180mm – 2kW
- 1 Dia. 210mm – 3kW
- 1 Dia. 280mm – 3kW

OPTIONAL EXTRAS

- Cast iron induction griddle [iGRIDDLE3]

INSTALLATION

- Diagram [p.220]
- Rated load 7.4kW
- Fuse rating 25A

INDUCTION HOB



FEATURES

BRIDGEABLE ZONES

The C858i zones provide complete flexibility in allowing either use of 4 individual zones, the option to combine zones into 2 larger zones for use with oversized pans or fish kettles.

PRODUCT CODE

C858i

DIMENSIONS

w:590mm

FINISH AVAILABLE

Black Glass

FEATURES

- Black frameless
- Touch control
- Bridgeable zones
- 10 Level digital power display for each zone [0-9 plus Booster]
- Booster function on each zone
- Programmable timer for each zone to set finish time [up to 99 mins]
- Minute minder
- Memory recall
- Pause function
- Child lock

- Residual heat indicators
- Automatic pan and small object detection
- Automatic safety shut-off
- Anti-overheat
- Anti-overflow

COOKING OUTPUT

4 Induction Zones

- 4 Dia. 220mm – 3kW

2 Alternative Dual Zones

- 2 Dia. 220 x 400mm – 4kW

OPTIONAL EXTRAS

- Cast iron induction griddle [iGRIDDLE3]

INSTALLATION

- Diagram [p.220]
- Rated load 7.2kW
- Fuse rating 25A

INDUCTION HOB

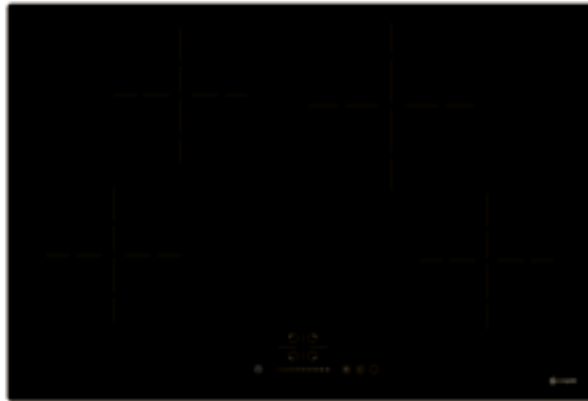

PRODUCT CODE

C8641i

DIMENSIONS

↔ w:770mm

FINISH AVAILABLE

■ Black Glass

FEATURES

- 10 Level digital power display for each zone [0-9 plus Booster]
- Frameless
- Booster function on each zone
- Minute minder
- Programmable timer on each zone to set finish time [up to 99 mins]
- Child lock
- Residual heat indicators

- Automatic safety shut off
- Automatic pan detection
- Anti-overheat
- Anti-overflow
- Slider touch control with direct access
- Red display colour

COOKING OUTPUT

4 Induction Zones

- 1 Dia. 210mm/2.6kW
- 2 Dia. 180mm/2.3kW
- 1 Dia. 160mm/1.5kW

OPTIONAL EXTRAS

- Cast iron induction griddle [iGRIDDLE3]

INSTALLATION

- Diagram [p.220]
- Rated load 8.7kW
- Fuse rating 25A

INDUCTION HOB



PRODUCT CODE

C8641iGM

DIMENSIONS

↔ w:770mm

FINISH AVAILABLE

■ Gunmetal

FEATURES

- 10 Level digital power display for each zone [0-9 plus Booster]
- Frameless
- Booster function on each zone
- Minute minder
- Programmable timer on each zone to set finish time [up to 99 mins]
- Child lock
- Residual heat indicators
- Automatic safety shut off

- Automatic pan detection
- Anti-overheat
- Anti-overflow
- Slider touch control with direct access
- Red display colour

COOKING OUTPUT

4 Induction Zones

- 2 Dia. 180mm/2.3kW
- 1 Dia. 210mm/2.6kW
- 1 Dia. 160mm/1.5kW

OPTIONAL EXTRAS

- Cast iron induction griddle [iGRIDDLE3]

INSTALLATION

- Diagram [p.220]
- Rated load 8.7kW
- Fuse rating 25A

FEATURES



GUNMETAL COLLECTION

Our Gunmetal range includes both appliances, sinks & taps so you can create a cohesive and contemporary aesthetic in your kitchen.

INDUCTION HOB



PRODUCT CODE

C8400i

DIMENSIONS

↔ w:590mm

FINISH AVAILABLE

■ Black Glass

FEATURES

- Frameless
- 10 level digital power display for each zone [0-9 plus Booster]
- Booster function on 4 zones
- Dial controls
- Red display
- Minute minder
- Programmable timer on each zone
- Child lock
- Residual heat indicators

- Automatic safety shut-off
- Automatic pan detection
- Anti-overheat
- Anti overflow

COOKING OUTPUT

4 Induction Zones

- 2 Dia. 140mm – 1.5kW with Booster
- 2 Dia. 220mm – 2.6kW with Booster

OPTIONAL EXTRAS

- Cast iron induction griddle [iGRIDDLE3]

INSTALLATION

- Diagram [p.220]
- Rated load 7kW
- Fuse rating 25A

INDUCTION HOB



PRODUCT CODE

C847i

DIMENSIONS

↔ w:590mm

FINISH AVAILABLE

■ Black Glass

FEATURES

- Frameless
- Slider touch control with direct access
- 10 Level digital power display for each zone [0-9 plus Booster]
- Booster function on each zone
- Minute minder
- Child lock
- Residual heat indicators
- Automatic safety shut-off

- Automatic pan detection
- Programmable timer for each zone to set finish time [up to 99 mins]
- Anti-overheat
- Anti overflow

COOKING OUTPUT

4 Induction Zones

- 2 Dia. 140mm – 1.5kW with Booster
- 2 Dia. 220mm – 2.6kW with Booster

OPTIONAL EXTRAS

- Cast iron induction griddle [iGRIDDLE3]

INSTALLATION

- Diagram [p.220]
- Rated load 7kW
- Fuse rating 25A



iGRIDDLE3

Griddle with ease using the iGRIDDLE3. Designed for use with all Caple induction hobs, it also gives excellent results when used with bridgeable hob zones for perfectly even cooking. Ideal for veggies, meats, and more - cleanup is a breeze, just pop it in the dishwasher.

INDUCTION HOB



PRODUCT CODE

C845i

DIMENSIONS

w:590mm

FINISH AVAILABLE

Black Glass

FEATURES

- Frameless
- Easy fit fixing clips
- Touch control

- Booster function on 4 zones
- 9 Level digital power display for each zone
- Minute minder
- Child lock

- Residual heat indicators
- Automatic safety shut-off
- Automatic pan detection
- Programmable timer for one zone to set finish time [up to 99 mins]

- Anti-overheat
- Anti overflow

COOKING OUTPUT

4 Induction Zones

- 1 Dia. 160mm - 1.5kW
- 1 Dia. 210mm - 2.6kW
- 2 Dia. 180mm - 2kW

OPTIONAL EXTRAS

- Cast iron induction griddle [iGRIDDLE3]

INSTALLATION

- Diagram [p.220]
- Rated load 7.2kW
- Fuse rating 25A

FEATURES



EASY INSTALLATION

Use the easy fit fixing clips for a simple installation.

Once the fixing clips are screwed to the hob casing, effortlessly push the hob into the worktop to secure it.

INDUCTION HOB - 13 AMP



PRODUCT CODE

C841i

DIMENSIONS

w:590mm

FINISH AVAILABLE

Black Glass

FEATURES

- Frameless
- Touch control
- 9 Level digital power display

- Minute minder
- Child lock
- Residual heat indicators
- Automatic safety shut-off
- Automatic pan detection

- Anti-overheat
- Anti-overflow
- Supplied with a 13A plug for easy installation in any kitchen
- Programmable timer for one zone to set finish time [up to 99 mins]

COOKING OUTPUT

4 Induction Zones

- 2 Dia. 180mm – 1.5kW
- 2 Dia. 180mm – 2kW

OPTIONAL EXTRAS

- Cast iron induction griddle [iGRIDDLE3]

INSTALLATION

- Diagram [p.220]
- Rated load 3kW
- Fuse rating 13A

IGRIDDLE3

Griddle with ease using the iGRIDDLE3. Designed for use with all Caple induction hobs, it also gives excellent results when used with bridgeable hob zones for perfectly even cooking. Ideal for veggies, meats, and more - cleanup is a breeze, just pop it in the dishwasher.



PLEASE NOTE: The C841i induction hob achieves a 13A connection by restricting the maximum load to 3kW, this is done by cleverly limiting the combined zones to a maximum power level sum of 12. For example if you had boiling water on power level 6 on one zone you could cook rice on power level 4 and gently warm food on level 2 on a third zone.



The Power of Electric Hobs.

Caple's electric ceramic hobs are engineered with performance, versatility and ease of use in mind.

The smooth Black Glass makes cleaning easy and thanks to minimalist styling our frameless ceramic models will fit into any type of kitchen.

Each hob has four separate zones offering different sizes, with individual lights that glow when activated. Touch control models set seamlessly into the worktop, but if you prefer more traditional operation opt for one of the dial control models.



ELECTRIC CERAMIC HOB



PRODUCT CODE

C8301C

DIMENSIONS

↔ w:900mm

FINISH AVAILABLE

■ Black Glass

FEATURES

- Frameless
- 9 power levels
- 2 extended cooking zones
- Slider touch control with direct access
- Red display
- Minute minder
- Programmable timer on each zone
- Child lock
- Residual heat indicators
- Auto safety shut off
- Anti-overheat

COOKING OUTPUT

- 5** Ceramic Plates
- 1 Dia. 200mm – 1.8kW
 - 2 Dia. 165mm – 1.2kW
 - 1 Dia. 165/270mm - 1.1kW/2.0kW
 - 1.Dia 140/230mm - 1.0kW/2.0kW

INSTALLATION

- Diagram [p.221]
- Rated load 9.2kW
- Fuse rating 25A

ELECTRIC CERAMIC HOB



PRODUCT CODE

C8241C

DIMENSIONS

↔ w:770mm

FINISH AVAILABLE

■ Black Glass

FEATURES

- Frameless
- 9 power levels
- 2 extended cooking zones
- Touch control
- Red display
- Minute minder
- Programmable timer on each zone

- Child lock
- Residual heat indicators
- Automatic safety shut-off
- Anti-overheat

COOKING OUTPUT

- 4** Ceramic Plates
- 1 Dia. 200mm/1.8kW
 - 1 Dia. 165mm/1.2kW
 - 1 dia. 165/270mm/1.1/2.0kW
 - 1 dia. 140/230mm/1.0/2.2kW

INSTALLATION

- Diagram [p.221]
- Rated load 6.3kW
- Fuse rating 25A

ELECTRIC CERAMIC HOB



PRODUCT CODE

C816C

DIMENSIONS

↔ w:590mm

FINISH AVAILABLE

■ Black Glass

FEATURES

- Frameless
- Touch control
- Red display
- 9 power levels
- Programmable timer on each zone

- Minute minder
- Residual heat indicators
- Child lock
- Automatic safety shut-off
- Anti-overheat

COOKING OUTPUT

- 4** Ceramic Plates
- 2 Dia. 200mm – 1.8kW
 - 2 Dia. 165mm – 1.2kW

INSTALLATION

- Diagram [p.221]
- Rated load 6.6kW
- Fuse rating 25A

ELECTRIC CERAMIC HOB

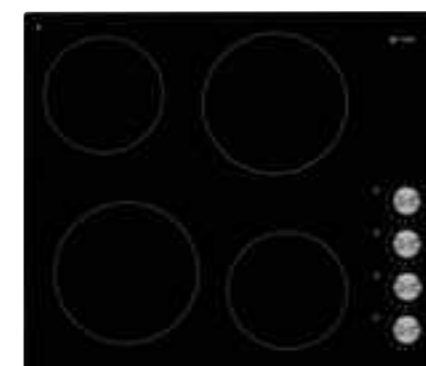

PRODUCT CODE

C809C

DIMENSIONS

↔ w:590mm

FINISH AVAILABLE

■ Black Glass

FEATURES

- Frameless
- Indicator lights for each zone
- Dial controls
- Red display
- Residual heat indicators

COOKING OUTPUT

- 4** Ceramic Plates
- 2 Dia. 200mm – 1.8kW
 - 2 Dia. 165mm – 1.2kW

OPTIONAL EXTRAS

- 2 Black dials [CKNOB5BK]

INSTALLATION

- Diagram [p.221]
- Rated load 6.6kW
- Fuse rating 25A

Gas-on-Glass Hobs.

If you're looking for a hob that combines contemporary design with power and functionality, this one ticks all the boxes.

That elegant glass surface doesn't just look stunning, it makes your hob simple to clean, while linked cast iron pan supports let you easily transfer pans across burners or away from the heat. All burners are Flame Safe, so if a flame is extinguished for any reason, the gas supply is cut straight away. Some hobs also feature a responsive triple ring burner for extra powerful cooking.



DirectHeat+

Designed with efficiency in mind, DirectHeat+ forces the heat directly towards the base of the pan via 45° inclined flame. More heat hits the base of the pan rather than escaping around the sides, therefore decreasing boiling time and bringing food to temperature more rapidly.

TOUCH PRECISION CONTROLS

Touch controls set into Black tempered glass look fabulous, but beauty is more than skin deep. Advanced digital technology gives you nine precise power levels on each burner, so they also offer an exceptional level of control.

GUNMETAL COLLECTION

At Caple, we know how important it is to co-ordinate colours in the kitchen, which is why the Gunmetal trend continues with our gas hobs. The sleek Black Glass and cool Gunmetal control work together in perfect harmony.

GAS-ON-GLASS HOB



C7591G



C7571G



C7561G

PRODUCT CODE

C7591G
C7571G
C7561G

DIMENSIONS

↔	w:860mm	C7591G
	w:760mm	C7571G
	w:591mm	C7561G

FINISH AVAILABLE

■ Black Glass

FEATURES

- Easy clean design
- Cast iron magnetic pan supports
- Flame safety device
- Auto electronic ignition
- Dial controls
- LPG jets included

COOKING OUTPUT

5 Gas Burners [C7591G and C7571G]

- 1 Triple ring burner: 4kW
- 1 Rapid burner: 3kW
- 2 Semi-rapid burners: 1.75kW
- 1 Simmer burner: 1kW

4 Gas Burners [C7561G]

- 1 Triple ring burner: 4kW
- 2 Semi-rapid burners: 1.75kW
- 1 Simmer burner: 1kW

OPTIONAL EXTRAS

- 2 Black dials [CKNOB5BK]

INSTALLATION

- Diagram [p.221]
- Fuse rating 3A

LOW PROFILE GAS HOBS



C7011G



C7091G



C7071G

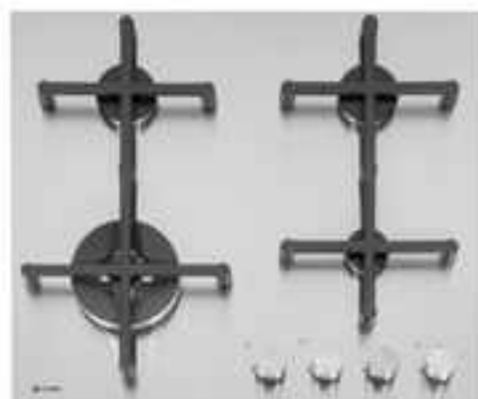

C7061G

PRODUCT CODE

C7011G

C7091G

C7071G

C7061G

DIMENSIONS

	w:1000mm	C7011G
	w:860mm	C7091G
	w:760mm	C7071G
	w:591mm	C7061G

FINISH AVAILABLE

Stainless Steel

FEATURES

- Low profile 1.2mm edge
- Cast iron magnetic pan supports
- Flame safety device
- Auto electronic ignition
- Dial controls
- LPG jets included

COOKING OUTPUT

5 Gas Burners [C7091G and C7071G]

- 1 Triple ring burner: 4kW
- 1 Rapid burner: 3kW
- 2 Semi-rapid burners: 1.75kW
- 1 Simmer burner: 1kW

4 Gas Burners [C7011G]

- 1 Triple ring burner: 4kW
- 1 Rapid burner: 3kW
- 1 Semi-rapid burners: 1.75kW
- 1 Simmer burner: 1kW

4 Gas Burners [C7061G]

- 1 Triple ring burner: 4kW
- 2 Semi-rapid burners: 1.75kW
- 1 Simmer burner: 1kW

INSTALLATION

- Diagram [p.221]
- Fuse rating 3A

GAS HOBS



C4091G



C4071G



C4061G

PRODUCT CODE

C4091G

C4071G

C4061G

DIMENSIONS

	w:860mm	C4091G
	w:760mm	C4071G
	w:580mm	C4061G

FINISH AVAILABLE

Stainless Steel

FEATURES

- Cast iron pan supports
- Flame safety device
- Auto electronic ignition
- Dial controls
- LPG jets included

COOKING OUTPUT

5 Gas Burners [C4071G and C4091G]

- 1 Triple ring burner: 4kW
- 1 rapid burner: 3kW
- 2 Semi-rapid burner: 1.75kW
- 1 Simmer burner: 1kW

4 Gas Burners [C4061G]

- 1 Triple ring burner: 4kW
- 2 Semi-rapid burner: 1.75kW
- 1 Simmer burner: 1kW

INSTALLATION

- Diagram [p.221 - 222]
- Fuse rating 3A

GAS-ON-GLASS HOBS

DirectHeat+



C789G

DirectHeat+



C787G

DirectHeat+



C786G

PRODUCT CODE

C789G

C787G

C786G

DIMENSIONS

↔	w:874mm	C789G
	w:700mm	C787G
	w:584mm	C786G

FINISH AVAILABLE

- Black Glass with Stainless Steel control panel

FEATURES

- DirectHeat+
- Flame safety device
- Cast iron pan supports
- Auto electronic ignition
- Dial controls
- LPG jets included

COOKING OUTPUT

5 Gas Burners [C789G and C787G]

- 1 Triple ring burner: 4.2kW
- 1 rapid burner: 2.7kW
- 2 semi-rapid burners: 1.75kW
- 1 simmer burner: 1.0kW

4 Gas Burners [C786G]

- 1 Triple ring burner: 3.6kW
- 2 semi-rapid burners: 1.75kW
- 1 simmer burner: 1.0kW

INSTALLATION

- Diagram [p.222]
- Fuse rating 3A



GAS-ON-GLASS HOBS



C944G



C744G

PRODUCT CODE

C944G

C744G

DIMENSIONS

↔	w:750mm	C944G
	w:580mm	C744G

FINISH AVAILABLE

- Black Glass

FEATURES

- Flame safety device
- Cast iron pan supports
- Auto electronic ignition
- Dial controls
- LPG jets included

COOKING OUTPUT

5 Gas Burners [C944G]

- 1 Triple ring burner: 3kW
- 1 Rapid burner: 2.4kW
- 2 Semi-rapid burners 1.88kW
- 1 Simmer burner: 0.9kW

4 Gas Burners [C744G]

- 1 Triple ring burner: 3kW
- 2 semi-rapid burners: 1.88kW
- 1 simmer burner: 0.9kW

OPTIONAL EXTRAS

- 2 Black dials [CKNOB5BK]

INSTALLATION

- Diagram [p.222]
- Fuse rating 3A

FEATURES

DirectHeat+

Designed with efficiency in mind, DirectHeat+ forces the heat directly towards the base of the pan via 45° inclined flame. More heat hits the base of the pan rather than escaping around the sides, therefore decreasing boiling time and bringing food to temperature more rapidly.



GAS-ON-GLASS HOBS



C889G



C887G



C886G

PRODUCT CODE

C889G

C887G

C886G

DIMENSIONS

	w:876mm	C889G
	w:700mm	C887G
	w:586mm	C886G

FINISH AVAILABLE

Gunmetal and Black Glass

FEATURES

- Black Glass, with Gunmetal front panel
- Flame safety device
- Cast iron pan supports
- Auto electronic ignition
- Dial controls
- LPG jets included

COOKING OUTPUT

5 Gas Burners [C889G + C887G]

- 1 Triple ring burner: 3kW
- 1 Rapid burner: 2.4kW
- 2 Semi-rapid burners 1.88kW
- 1 Simmer burner: 0.9kW

4 Gas Burners [C886G]

- 1 Triple ring burner: 3kW
- 2 semi-rapid burners: 1.88kW
- 1 simmer burner: 0.9kW

INSTALLATION

- Diagram [p.222 - 223]
- Fuse rating 3A

Low Profile Gas Hobs.

Those who've cooked on gas rarely go back to any other hob. Gas rings provide immediate heat, and are intuitive, reliable, and super-easy to control.

Our gas hobs come in sleek Stainless Steel or smooth finishes, and look fantastic in contemporary or classic kitchens.



Unrivalled performance and looks, coupled with ease of fitting. Caple low profile hobs are designed to sit on top of the work surface with the smallest of edges.

They give you the appearance of a professional kitchen with added Caple refinement.

FEATURES



GUNMETAL COLLECTION

Our Gunmetal range includes both appliances, sinks & taps so you can create a cohesive and contemporary aesthetic in your kitchen.

GAS HOBS



C775G

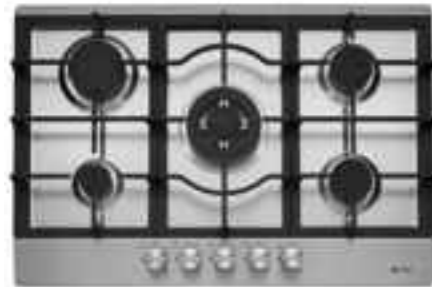

C768G



C750G

PRODUCT CODE

C775G

C768G

C750G

DIMENSIONS

↔	w:860mm	C775G
	w:750mm	C768G
	w:590mm	C750G

FINISH AVAILABLE

■ Stainless Steel

FEATURES

- Flame safety device
- Cast iron pan supports
- Auto electronic ignition
- Dial controls
- LPG jets included

COOKING OUTPUT

5 Gas Burners
[C775G + C768G]

- 1 Triple ring burner: 3.3kW
- 1 Rapid burner: 3kW
- 2 Semi-rapid burners: 1.75kW
- 1 Simmer burner: 1kW

4 Gas Burners [C750G]

- 1 Rapid burner: 3kW
- 2 Semi-rapid burners: 1.75kW
- 1 Simmer burner: 1kW

INSTALLATION

- Diagram [p.223]
- Fuse rating 3A

GAS HOB



PRODUCT CODE

C706G

DIMENSIONS

↔	w:580mm
---	---------

FINISH AVAILABLE

■ Stainless Steel

FEATURES

- Flame safety device
- Enamelled pan supports
- Auto electronic ignition
- Dial controls
- LPG jets included

COOKING OUTPUT

4 Gas Burners

- 1 Triple ring burner: 3.0kW
- 2 Semi-rapid burners: 1.88kW
- 1 Simmer burner: 0.9kW

INSTALLATION

- Diagram [p.223]
- Fuse rating 3A



Modular Hobs.

Now you can build the perfect hob for your needs. Combine electric or induction hob with a modular, flip downdraft for a truly bespoke solution that's sure to impress.

Modular hobs are ideal when space is at a premium or you want to combine two cooking functions.

INDUCTION MODULAR HOB



PRODUCT CODE

C997i

DIMENSIONS

w:288mm

FINISH AVAILABLE

Black Glass

FEATURES

- Frameless
- Touch control
- Red display
- Booster function on each zone
- 9 Level digital power display
- Minute minder
- Programmable timer set finish time [up to 99 mins]

- Child lock
- Residual heat indicators
- Automatic safety shut-off
- Automatic pan detection
- Anti-overheat
- Anti-overflow

COOKING OUTPUT

2 Induction Zones

- 1 Dia. 160mm – 1.5kW
- 1 Dia. 180mm – 2kW

OPTIONAL EXTRAS

- Cast iron induction griddle [iGRIDDLE3]

INSTALLATION

- Diagram [p.223]
- Rated load 3.5kW
- Fuse rating 16A

ELECTRIC CERAMIC MODULAR HOB



PRODUCT CODE

C894C

DIMENSIONS

w:288mm

FINISH AVAILABLE

Black Glass

FEATURES

- Frameless
- Audible touch control
- 9 Level digital power display for each zone

- Programmable timer set finish time [up to 99 mins]
- Automatic stop and temperature limiter
- Child safety lock
- Residual heat indicators

COOKING OUTPUT

2 Ceramic Plates

- 1 Dia. 165mm – 1.2kW
- 1 Dia. 200mm – 1.8kW

INSTALLATION

- Diagram [p.223]
- Rated load 3.3kW
- Fuse rating 16A

GAS MODULAR HOB



PRODUCT CODE

C890G

DIMENSIONS

w:290mm

FINISH AVAILABLE

Black Glass

FEATURES

- Cast iron pan supports
- Flame safety device
- LPG jets included
- Dial controls

COOKING OUTPUT

2 Gas Burners

- 1 rapid burners 2.4kW
- 1 semi-rapid burners 1.88kW

OPTIONAL EXTRAS

- 2 Black dials [CKNOB5BK]

INSTALLATION

- Diagram [p.223]
- Fuse rating 3A

Induction Downdraft Extractors.

SEAMLESS INTEGRATION + UNMISTAKABLE STYLING.

As the name suggests induction downdrafts combine intuitive induction hobs with the added benefit of integrated, powerful downdraft extraction.

SPACE SAVING INSTALLATION

Unique space-saving installation can be used with minimal ducting and the motor located behind the plinth which means you can still utilise the cabinets directly underneath the hob. For installation see p.224 - 226.

PLASMA TECHNOLOGY

With cutting-edge technology, our new advanced filter not only rids away odours with plasma but also tackles fine dust and contaminants. For more information, turn to page 94.

IGRIDDLE3

Griddle veggies, meats, and more, with the induction-friendly iGRIDDLE3. It works seamlessly with bridgeable hob zones for even cooking, and cleanup's a breeze too—just pop it in the dishwasher!





INDUCTION DOWNDRAFT EXTRACTOR

PRODUCT CODE

DD820BK

DIMENSIONS

↳ w:800mm

PERFORMANCE

e Energy class A
Fluid dynamic efficiency B
Grease absorption A
Annual consumption
39kWh/yr
Max. extraction 602m³/h
Max. Noise Level 66dB

FINISH AVAILABLE

■ Black Glass

FEATURES

Hob

- Black Glass with Black extractor grille
- Frameless
- Suitable for flush or inset installation
- Invisi touch control with direct access
- 10 power levels [0-9 and Booster]
- Booster function on all zones, including Auto Boost mode
- Timer function per zone / minute minder
- Bridge function
- Auto boost function
- Child lock
- Memory recall function
- Residual heat indicators
- Anti-overheat protection
- Anti Over flow
- Automatic safety shut-off
- Auto pan detection
- Preset temperature setting [keep warm 70°C]

Downdraft

- Touch control
- 10 Speeds [0-9 and Boost]
- Auto 10 - 60 minute timer, switch-off after 10mins
- Ducting spigot size 150mm
- Can be ducted or recirculated
- Plinth motor included
- Recirculation ducting kit available
- Plasma filtration available
- Recirculation kit available

COOKING OUTPUT

- 210 x 190mm 2100W/3000W
- 210 x 190mm 2100W/3000W
- 200mm 2300W/3000W
- 160mm 1400W/2100W

OPTIONAL EXTRAS

- Plasma filter [GUC1314]
 - Recirculation Kit [CAP83CF]
 - Ducting for use with Recirculation Kit [KIT/961W]
 - Replacement Charcoal Filter [CAP84CF]
 - Cast iron induction griddle [iGRIDDLE3]
- Visit caple.co.uk for full range

INSTALLATION

- Space saving installation diagram [p.224]
- Venting Kits [p.136]
- Fuse rating 32A



INDUCTION DOWNDRAFT EXTRACTOR

PRODUCT CODE

DD810BK

DIMENSIONS

↳ w:800mm

PERFORMANCE

e Energy class A+
Grease absorption A
Annual consumption
24kWh/yr
Max. extraction 570m³/h
Max. noise level 70dB

FINISH AVAILABLE

■ Black Glass

FEATURES

Hob

- Black Glass with Stainless Steel extractor grille
- Frameless
- Suitable for flush or inset installation
- Invisi touch control with direct access
- 10 power levels [0-9 and Booster]
- Booster function on each zone, including Auto Boost mode
- Timer function per zone / minute minder
- Bridge function
- Auto boost function
- Child lock
- Memory recall function
- Residual heat indicators

- Anti-overheat protection
- Anti Over flow
- Automatic safety shut-off
- Auto pan detection
- Preset temperature setting [keep warm 70°C]

Downdraft

- Touch control
- 10 Speeds [0-9 and Boost]
- Auto 10 - 60 minute timer, switch-off after 10mins
- Ducting spigot size 150mm
- Can be ducted or recirculated
- Motor included
- Plasma filtration available
- Recirculation ducting kit available
- Recirculation kit available

COOKING OUTPUT

- 4** Induction Zones
- 190mm 2100W/3000W
 - 190mm 2100W/3000W
 - 200mm 2300W/3000W
 - 160mm 1400W/2100W

OPTIONAL EXTRAS

- Plasma filter [GUC1314]
 - Recirculation Kit [CAP83CF]
 - Ducting for use with Recirculation Kit [KIT/960W]
 - Replacement Charcoal Filter [CAP84CF]
 - Cast iron induction griddle [iGRIDDLE3]
- Visit caple.co.uk for full range

INSTALLATION

- Space saving installation diagram [p.224]
- Fuse rating 32A

FEATURES



INTEGRATED MOTOR

The integrated motor situated below the induction hob provides an easy installation solution. You also have the option to recirculate the air using charcoal filter or duct to the outside world.

MULTI ZONE INDUCTION HOB

These hobs provide complete flexibility allowing either the use of individual zones or the ability to combine them to create larger cooking areas. If you cook regularly using oversized pans such as fish kettles, these hobs will handle them with ease.



INDUCTION DOWNDRAFT EXTRACTOR

PRODUCT CODE

DD780BK

DIMENSIONS

↳ w:780mm

PERFORMANCE

e Energy class A
Grease absorption C
Annual consumption 46kWh/yr
Max. extraction 648m³/h
Max. noise level 71dB

FINISH AVAILABLE

■ Black Glass

FEATURES

Hob

- Black Glass with Stainless Steel extractor grille
- Frameless
- Touch controls
- 10 power levels [0-9 and Booster]
- Booster function on each zone
- Timer function per zone
- Bridge function
- Child lock
- Residual heat indicators
- Anti-overheat protection
- Anti Over flow
- Automatic safety shut-off
- Auto pan detection

Downdraft

- Touch controls
- 4 Speeds
- Auto timer, switch-off after 15mins
- Ducting spigot size 150mm
- Plasma filtration available
- Plinth motor included
- Recirculation kit available

COOKING OUTPUT

- 4** Induction Zones
- 160mm 1400W/1800W
 - 160mm 1400W/1800W
 - 200mm 2100W/2500W
 - 200mm 2100W/2500W

OPTIONAL EXTRAS

- Plasma filter [GUC1314]
 - Replacement charcoal filter [CAP81CF]
 - Cast iron induction griddle [iGRIDDLE3]
- Visit caple.co.uk for full range

INSTALLATION

- Space saving installation diagram [p.225]
- Fuse rating 32A



IGRIDDLE3

Griddle with ease using the iGRIDDLE3. Designed for use with all Caple induction hobs, it also gives excellent results when used with bridgeable hob zones for perfectly even cooking. Ideal for veggies, meats, and more - cleanup is a breeze, just pop it in the dishwasher.



INDUCTION DOWNDRAFT EXTRACTOR

PRODUCT CODE

DD610BK

DIMENSIONS

↳ w:600mm

PERFORMANCE

e Energy class B
Fluid dynamic efficiency B
Grease absorption A
Annual consumption 35kWh/yr
Max. extraction 562m³/h
Max. Noise Level 75dB

FINISH AVAILABLE

■ Black Glass

FEATURES

Hob

- Black Glass with Black extractor grille
- Frameless
- Suitable for flush or inset installation
- Invisi touch control with direct access
- 10 power levels [0-9 and Booster]
- Booster function on all zones, including Auto Boost mode
- Timer function per zone / minute minder
- Bridge function
- Auto boost function
- Child lock
- Memory recall function
- Residual heat indicators
- Anti-overheat protection

- Anti Over flow
- Automatic safety shut-off
- Auto pan detection
- Preset temperature setting [keep warm 70°C]

Downdraft

- Touch control
- 10 Speeds [0-9 and Boost]
- Auto 10 - 60 minute timer, switch-off after 10mins
- Ducting spigot size 150mm
- Can be ducted or recirculated
- Motor included
- Recirculation ducting kit available
- Plasma filtration available
- Recirculation kit available

COOKING OUTPUT

- 210 x 190mm 2100W/3000W
- 210 x 190mm 2100W/3000W
- 210 x 190mm 2100W/3000W
- 210 x 190mm 2100W/3000W

OPTIONAL EXTRAS

- Plasma filter [GUC1314]
 - Recirculation Kit [CAP83CF]
 - Ducting for use with Recirculation Kit [KIT/960W]
 - Replacement Charcoal Filter [CAP84CF]
 - Cast iron induction griddle [iGRIDDLE3]
- Visit caple.co.uk for full range

INSTALLATION

- Space saving installation diagram [p.226]
- Venting Kits [p.136]
- Fuse rating 32A

FEATURES



INTEGRATED MOTOR

The integrated motor situated below the induction hob provides an easy installation solution. You also have the option to recirculate the air using charcoal filter or duct to the outside world.

MULTI ZONE INDUCTION HOB

These hobs provide complete flexibility allowing either the use of individual zones or the ability to combine them to create larger cooking areas.

If you cook regularly using oversized pans such as fish kettles, these hobs will handle them with ease.

Extraction.

A well-engineered extractor hood does more than just help to capture odours from your kitchen. Be bold, and use it as a visual focal point too.



Choosing the Perfect Hood.

We've designed one for every kind of kitchen. Striking colours, exceptional finishes, and plenty of functionality.

Extractors and hoods are designed to remove cooking odours, moisture and grease from the cooking environment. The extractor continually removes and filters the air when on. It then, either, returns the filtered air back in to the room or expels it through an external vent. The greater the extraction rate the more effectively this is done.

GETTING THE BEST FROM YOUR HOOD.

Try switching on the extractor or hood 15 minutes before you begin cooking. This creates kinetic air circulation within the kitchen carrying the air out more effectively. It is also advisable to keep it running for a further 15 minutes after you have finished cooking.

You can sit down and enjoy the results of your culinary skills whilst your Caple extractor or hood gets on with its job.

Once you have chosen your extractor, it is important to pair it with the correct venting. It is essential the stated ducting diameter is used, we also recommend rigid ducting to ensure you get the maximum performance. Not only will this prolong the life of your extractor, it will also improve efficiency.



If you choose to vent your extractor to the outside world, look out for the venting symbol shown to assist you in choosing the correct product. Please see p.136 - 137. for more information.



INDUCTION DOWNDRAFTS

This award-winning category of extraction is ideal for open plan living. The powerful extraction eradicates cooking odours from the room and the minimal aesthetics discreetly blends into the worktop for a seamless look. See our range of Induction downdraft hobs in the hob section, p.85.



DOWNDRAFT EXTRACTORS

This type of counter extractor is installed behind or alongside your hob. When you need it, just press the button and it glides up into position.



WALL CHIMNEY HOODS

Available in all kinds of sizes, styles and finishes. Great for a dramatic focal point.



BUILT-UNDER HOODS

Ideal for smaller kitchens. They're cleverly integrated into the underside of kitchen units.



CEILING HOODS

They're unobtrusive and they save you space too. You can choose different motors and have complete control over extraction rates.



ISLAND HOODS

Better suited to larger kitchens. You can suspend them over a central island unit to make a stunning focal point.



INTEGRATED HOODS

Discretely hidden behind kitchen furniture, and pulled out when needed.



CONVENTIONAL HOODS

This type fits neatly beneath a kitchen unit, with controls usually found on the front.

Plasma

This compact powerhouse not only rids odours with plasma but also tackles fine dust and contaminants using cutting-edge electrostatic discharge [ESD] technology all combined in one filter, making it one of a kind and worldwide patented.



An important advantage of a recirculation filter is that you save a significant amount of money on your heating costs, because the filter keeps the heated or cooled air inside.



With correct use and regular cleaning of the grease filter of the extractor hood, the filter will last up to 15 years practically maintenance free



The PlasmaMade® E-Filter has specially been developed to prevent energy wastage in your home. Our filter is 97% recyclable.



Easy plug and play installation. Simply attach the PlasmaMade® Filter to the hood and insert the plug.



WHY CHOOSE CAPLE PLASMA?

Most kitchens use outdoor extraction or carbon filters to remove cooking odours. These are solutions that can be costly and unsustainable in the long term. The PlasmaMade® E-Filter is a revolutionary plasma filter with E-technology that offers a solution to these problems. The table on the next page shows a comparison between a PlasmaMade® E-Filter, regular recirculation filters and outdoor extraction.

PLASMAMADE E-FILTER	GENERAL RECIRCULATION FILTER	OUTDOOR EXHAUST VENT
Filters fine dust	Does not filter fine dust	Blows fine dust outside
Easy installation	Easy installation	Costly and complicated installation
Active filter technique, lasts 10 to 15 years	Passive filters, lasts 1/2 to 1 year	Air duct is difficult to clean
A filter for almost every extraction unit	Available for most extraction units	Fits on nearly every extractor hood
Cheaper in the long term	Costly through recurring replacement of filters	No recurring costs
Has a noise-reducing effect on the extractor hood	Increases the sound due to the high counterpressure of the compact carbon	Complex air ducts can cause high counter- pressure and noise
Very low power consumption [8 Watt]	Increases power consumption due to the high resistance or higher energy consumption	
Fully recyclable through the PlasmaMade® return system	Not recyclable	



PLASMA COMPATIBILITY

To see whether the PlasmaMade filter is available as an optional extra for your chosen extractor, look out for the logo.



PLASMA EXPLAINED

Scan the QR code for more information and how to make the most of your Caple products.

THE TECHNOLOGY BEHIND PURE AIR.

The patented PlasmaMade® filtering technology uses four individual techniques, which include the combination of Plasma and ESD to break down unpleasant smells and substances, recirculating clean and fresh air back into the room.

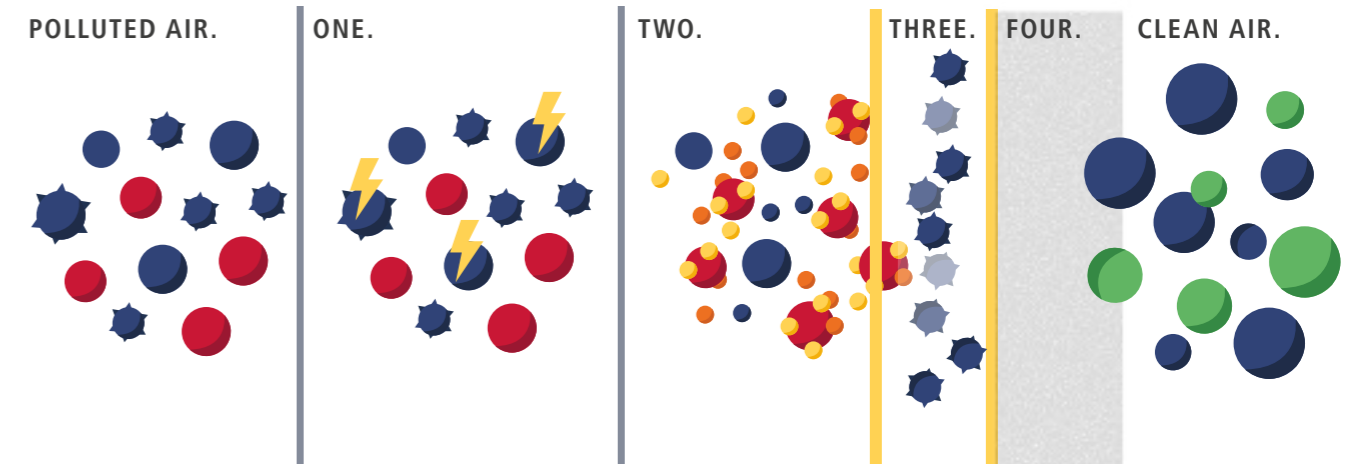

ONE.

The PlasmaMade® generator creates plasma by using a high voltage, this plasma neutralises odours and micro-organisms.

TWO.

Contaminations are caught in the electrostatically charged Nano fiberglass filter, which together with the conical inner design helps to ensure smooth air flow through the filter.

THREE.

The electrostatic discharge [ESD] filter uses a voltage of 1-4kV to break down contaminants [including grease, fine dust, pollen and bacteria].

FOUR.

The ceramic foam filter then helps to ensure everything gets caught, so only clean air is released back into the room, while also providing a sound dampening effect.



PLASMA FILTERS



PRODUCT CODE
GUC1212

FEATURES

- Plasma filter with ESD
- Helps to filter against, cooking odours, airborne viruses, bacteria, fungi, cigarette smoke, VOCs, pollen, fine dust and pet allergens
- For use in recirculation mode
- 150 Inlet diameter
- For use with wall/island hoods
- Max. Extraction 600m3/h
- Fully recyclable through the PlasmaMade return system
- Power consumption 6w/h
- 10/15 year lifespan
- Easy assembly
- Can be retrofitted
- Offset adaptor included
- Does NOT require the charcoal filter to be changed
- 2 year warranty [5 years after registering]
- UK plug included

INSTALLATION
- Diagram [p.226]



PRODUCT CODE
GUC1214

FEATURES

- Plasma filter with ESD
- Helps to filter against, cooking odours, airborne viruses, bacteria, fungi, cigarette smoke, VOCs, pollen, fine dust and pet allergens
- For use in recirculation mode
- 150 Inlet diameter
- For use with wall/island hoods
- Max. Extraction 1000m3/h
- Fully recyclable through the PlasmaMade return system
- Power consumption 8w/h
- 10/15 year lifespan
- Easy assembly
- Can be retrofitted
- Offset adaptor included
- Does NOT require the charcoal filter to be changed
- 2 year warranty [5 years after registering]
- UK plug included

INSTALLATION
- Diagram [p.226]



PRODUCT CODE
GUC1314

FEATURES

- Plasma filter with ESD
- Helps to filter against, cooking odours, airborne viruses, bacteria, fungi, cigarette smoke, VOCs, pollen, fine dust and pet allergens
- For use in recirculation mode
- 220 x 90 Inlet diameter
- For use with downdrafts/ceiling hoods
- Max. Extraction 1000m3/h
- Fully recyclable through the PlasmaMade return system
- Power consumption 8w/h
- 10/15 year lifespan
- Easy assembly
- Can be retrofitted
- Does NOT require the charcoal filter to be changed
- 2 year warranty [5 years after registering]
- UK plug included

INSTALLATION
- Diagram [p.226]

FEATURES



PLASMA EXPLAINED

Scan the QR code for more information and how to make the most of your Caple products.

Downdraft Extractors.

Caple downdraft extractors are the epitome of intelligent thinking in kitchen design. With an ingenious under-counter installation, wall space is kept clear and when integrated into an island unit, views across the kitchen remain uncluttered.

A downdraft extractor can be housed either behind or alongside a hob, in an island unit or within a base against a wall.



FLUSH FITTING

Fitting elegantly into the surface until activated, it rises out of the worktop beyond the height of the pans to extract odours directly from the cooking area.

These smart extractors deliver high extraction rates and give you a choice of motors and motor positioning options to suit your kitchen design. For example, your motor could be situated under the floor, on an external wall or in a cupboard, so noise can be virtually eliminated. With real versatility, our downdraft extractors can expel air via ducting or recirculate it using charcoal filters.

MOTOR CHOICES

Downdraft extractors will need to be purchased with a motor. For the full range please see p.108 - 109.

INVISIBLE MOTOR

The DDMEXT28 is designed to be easily and discreetly installed behind the plinth without the requirement of ducting to the outside of the building. For more details see p.108.



NOSTA DOWNDRAFT EXTRACTOR WITH LIGHT

PRODUCT CODE

DD925CO

DIMENSIONS

↔ w:880mm

PERFORMANCE

e Energy class A - C
For energy and performance see p.110 - 113.

FINISH AVAILABLE

■ Black Glass with Copper

FEATURES

- For use with gas or electric hobs
- 4 Speeds [inc. Boost function]
- Auto timer, switch-off after 10mins
- 14W white LED light
- Remote control operated
- Polished Stainless Steel grease filters
- Ducting spigot size 150mm
- Motor not included
- Recirculation kit available

MOTOR CHOICES

- Downdraft extractors will need to be purchased with a motor. For the full range please see p.108 - 109.

OPTIONAL EXTRAS

- Plasma filter [GUC1314 - only for use with motors DDMEXT11 and DDMEXT28]
 - Recirculation kit [CAP68CF - only for use with motors DDMEXT11 and DDMEXT28]
- Visit caple.co.uk for full range

INSTALLATION

- Diagram [p.227]
- Venting Kits [p.136]
- The electric box must be located at least 650mm from the hob

FEATURES

SMOOTH OPERATOR

At the touch of a button, the DD925CO rises smoothly up from its flush, retracted position.



DD925CO CLOSED

FLUSH DOWNDRAFT EXTRACTOR WITH LIGHT



OPTIONAL PLASMA

PRODUCT CODE

DD912BK

DIMENSIONS

↔ w:875mm

PERFORMANCE

e Energy class A+ - C
For energy and performance see p.110 - 113.

FINISH AVAILABLE

■ Black Glass with Stainless Steel

FEATURES

- Illuminated touch control
- 5W x LED Light
- For use with gas or electric hobs
- Perimetrical extraction for reduced noise and increased pressure resulting in improved motor performance
- 4 Speeds [inc. Boost function]
- Auto timer, switch-off after 10mins
- Aluminium grease filters
- Required ducting size 150mm
- Recirculation kit available

MOTOR CHOICES

- Downdraft extractors will need to be purchased with a motor. For the full range please see p.108 - 109.

OPTIONAL EXTRAS

- Plasma filter [GUC1314 - only for use with motors DDMEXT11 and DDMEXT28]
- Recirculation kit [CAP43CF only for use with motors DDMEXT11 and DDMEXT28]
Visit caple.co.uk for full range

INSTALLATION

- Diagram [p.227]
- Venting Kits [p.136]
- The electric box must be located at least 650mm from the hob

FLIP DOWNDRAFT



OPTIONAL PLASMA

PRODUCT CODE

DD903BK

DIMENSIONS

↔ w:845mm

PERFORMANCE

e Energy class A - C
For energy and performance see p.110 - 113.

FINISH AVAILABLE

■ Black Glass with Stainless Steel

FEATURES

- Illuminated touch control
- Motor speed indicator light
- For use with gas or electric hobs
- Perimetrical extraction for reduced noise and increased pressure resulting in improved motor performance
- 4 Speeds
- Auto timer, switch-off after 10mins
- Aluminium grease filters
- Required ducting size 150mm
- Motor not included
- Recirculation kit available

MOTOR CHOICES

- Downdraft extractors will need to be purchased with a motor. This model can be used with DDMEXT21, DDMEXT28 and DDMEXT31. For the full range please see p.108 - 109.

OPTIONAL EXTRAS

- Plasma filter [GUC1314 - only for use with motor DDMEXT28]
- Recirculation kit [2 x CAP66CF - only for use with motor DDMEXT28]
Visit caple.co.uk for full range

INSTALLATION

- Diagram [p.227]
- Venting Kits [p.136]
- The electric box must be located at least 650mm from the hob

PUSH DOWNDRAFT EXTRACTOR WITH LIGHT



OPTIONAL PLASMA

PRODUCT CODE

DD901BK

DIMENSIONS

↔ w:810mm

PERFORMANCE

e Energy class B - C
For energy and performance see p.110 - 113.

FINISH AVAILABLE

■ Black Glass with Stainless Steel

FEATURES

- Electronic push button controls
- Perimetrical extraction for reduced noise and increased pressure resulting in improved motor performance
- For use with gas or electric hobs
- 4 Speeds [inc. Boost function]
- Auto timer, switch-off after 10mins
- 2 x 3.9W white LED lights
- Stainless Steel and aluminium grease filters
- Required ducting size 150mm
- Motor not included
- Recirculation kit available

MOTOR CHOICES

- Downdraft extractors will need to be purchased with a motor. For the full range please see p.108 - 109.

OPTIONAL EXTRAS

- Plasma filter [GUC1314 - only for use with motors DDMEXT11 and DDMEXT28]
- Recirculation kit [CAP67CF - only for use with motors DDMEXT11 and DDMEXT28]
Visit caple.co.uk for full range

INSTALLATION

- Diagram [p.227]
- Venting Kits [p.136]
- The electric box must be located at least 650mm from the hob

VENTING

Ensure you purchase the correct venting for your Caple extractor. For the full range please see p.136 - 137.

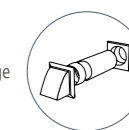



DOWNDRAFT EXTRACTOR



OPTIONAL PLASMA

PRODUCT CODE

DD523BK

DIMENSIONS

w:520mm

PERFORMANCE

e Energy class A++
 Fluid dynamic efficiency A
 Grease absorption C
 Annual consumption 32kWh/yr
 Max. extraction 680m³/h [boost]
 Max. noise level 63dB

FINISH AVAILABLE

Black Glass

FEATURES

Not only is the integrated motor situated just below the downdraft at hob level, but the extractor is designed to be installed into the same cut-out as the joining hobs, allowing for an easy installation.

FEATURES

- Motor included
- Touch control
- Can be used with gas hobs
- 4 Speeds
- Auto timer, switch-off after 10mins
- Aluminium grease filter
- Required ducting size 150mm
- Recirculation kit available

OPTIONAL EXTRAS

- Plasma filter [GUC1314]
 - Recirculation kit [CAP87CF]
 - Replacement charcoal filter [CAP88CF]
 - Plasma filter [GUC1314]
- Visit caple.co.uk for full range

INSTALLATION

- Diagram [p.227]
- Venting Kits [p.136]
- This product is designed to be installed in the same cut out as the joining hobs

MODULAR FLIP DOWNDRAFT EXTRACTOR



OPTIONAL PLASMA

PRODUCT CODE

DD522BK

DIMENSIONS

w:520mm

PERFORMANCE

e Energy class A - C
 For energy and performance see p.110 - 113.

FINISH AVAILABLE

Black Glass with Stainless Steel

FEATURES

- Illuminated touch controls
- For use with gas or electric hobs
- Perimetrical extraction for reduced noise and increased pressure resulting in improved motor performance
- Extracts from both sides, ideal for installation between modular hobs

- 4 Speeds
- Auto timer, switch-off after 10mins
- Aluminium grease filters
- Required ducting size 150mm
- Motor not included
- Recirculation kit available

MOTOR CHOICES

Downdraft extractors will need to be purchased with a motor. For the full range please see p.108 - 109.

OPTIONAL EXTRAS

- Plasma filter [GUC1314 - only for use with motor DDMEXT28]
 - Recirculation kit [CAP72CF - only for use with motor DDMEXT28]
- Visit caple.co.uk for full range

INSTALLATION

- Diagram [p.227]
- Venting Kits [p.136]
- The electric box must be located at least 650mm from the hob

VENTING

Ensure you purchase the correct venting for your Caple extractor. For the full range please see p.136 - 137.

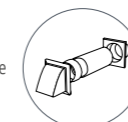

DOWNDRAFT EXTRACTOR



OPTIONAL PLASMA

PRODUCT CODE

DD606BK

DIMENSIONS

w:575mm

PERFORMANCE

e Energy class B - C
 For energy and performance see p.110 - 113.

FINISH AVAILABLE

Black Glass with Stainless Steel

FEATURES

- Electronic controls on Stainless Steel finish, touch control on Black Glass finish
- For use with gas or electric hobs
- Perimetrical extraction for reduced noise and increased pressure resulting in improved motor performance
- 4 Speeds [inc. Boost function]

- Auto timer, switch-off after 10mins
- Aluminium grease filters
- Required ducting size 150mm
- Motor not included
- Recirculation kit available

MOTOR CHOICES

Downdraft extractors will need to be purchased with a motor. For the full range please see p.108 - 109.

OPTIONAL EXTRAS

- Plasma filter [GUC1314 - only for use with motors DDMEXT11 and DDMEXT28]
 - Recirculation kit [CAP27CF - only for use with motors DDMEXT11 and DDMEXT28]
- Visit caple.co.uk for full range

INSTALLATION

- Diagram [p.228]
- Venting Kits [p.136]
- The electric box must be located at least 650mm from the hob

Ceiling Hoods.

Every Caple ceiling extractor uses our perimetric extraction system, which draws air in through narrow apertures around the full perimeter of the pan. It means higher air pressure, greater efficiency and less noise.



CREATING THE RIGHT ATMOSPHERE

You can also select just the right kind of lighting you want for your kitchen - from bright white to a soft, cosy, glow.

CONTROL AT YOUR FINGERTIPS

Our user-friendly remote control places power and lighting functions within easy reach. It also allows you to set the handy timer function, which automatically switches off the extractor after 10 minutes. When you leave your kitchen you know that any odours will be gone by the time you return.

CENTRE STAGE

We love the challenge of making functionality look stunning. Our hoods represent the epitome of contemporary design and technology. Perfectly complementing any other Caple product, our ceiling hoods provide performance and styling like no other. LED strip lighting, white glass finish and intelligent features ensure it has a place not only as a talking point in your kitchen, but an invaluable and practical addition.

CHOICES

Some models have unique built-in motors, others will need to be purchased with a motor. To get the right power for you see our full range of motors on p.108 - 109.



CEILING HOOD



OPTIONAL PLASMA

PRODUCT CODE

CE930

DIMENSIONS

↔ w:920mm

PERFORMANCE

e Energy class A+
 Fluid dynamic efficiency A
 Lighting efficiency D
 Grease absorption B
 Annual consumption 35kWh/yr
 Max. extraction 745m³/h [boost]
 Max. noise level 62dB

FINISH AVAILABLE

White
 Custom

FEATURES

- White centre panel supplied, also accepts a plaster board panel to match in with the ceiling
- Motor included
- Remote control included
- Perimetrical extraction for reduced noise and increased pressure resulting in improved motor performance
- 4 Speeds
- 1 x 11W LED light [dimmable]
- Adjustable light temperature [from cool to warm]
- Auto timer, switch-off after 10mins
- 2 x Aluminium grease filters
- Ducted only installation
- Ducting spigot size 150mm

OPTIONAL EXTRAS

- Plasma filter [GUC1314]
 Note: must be connected to ducting and requires a way to recirculate air back into room which must be created by the installer

INSTALLATION

- Diagram [p.228]
- Venting Kits [p.136]

FEATURES

STRIKING DROP-DOWN FUNCTIONALITY

Make a bold statement in your kitchen as the CE930 ceiling extractor's hood elegantly drops down, not only enhancing aesthetics but also optimising extraction performance.

CUSTOMISABLE CENTRE PANEL

Tailor the CE930 to your interior style with a white centre panel that can be effortlessly replaced with plasterboard and custom painted, ensuring a seamless blend with your décor.

ADJUSTABLE LIGHTS

Customise and coordinate the LEDs with your existing room lighting by adjusting from Warm to Cool white.

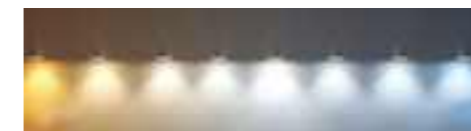

CEILING HOOD



OPTIONAL PLASMA

PRODUCT CODE

COR541SL

DIMENSIONS

w: 540mm
[light 750mm]

PERFORMANCE

Energy class B
Fluid dynamic efficiency B
Light efficiency E
Grease absorption F
Annual consumption 53kWh/yr
Max. extraction 540m³/h
Max. noise level 62dB[A]

FINISH AVAILABLE

Silver light ring
White ceiling extractor

FEATURES

ADJUSTABLE LIGHTS

The seamless integration of lighting and extraction puts the Corona in a league of it's own.

Customise and coordinate the LED's with your existing room lighting by adjusting from Warm to Cool white.

The 750mm wide, halo glow not only illuminates the hob below, it also creates the perfect ambience when entertaining.

FEATURES

- Motor included
- Remote control included
- 1 x 10W LED [dimnable and adjustable from warm to cool white 2700-6500K]
- 4 Speeds
- Stainless Steel grease filter
- Ducted only installation
- Required ducting size 150mm
- Perimetrical extraction for reduced noise and increased pressure resulting in improved motor performance
- Auto timer, switch-off after 10mins
- Integrated/hidden power cable to ring lighting
- Motor included

OPTIONAL EXTRAS

- Plasma filter [GUC1314]
Note: must be connected to ducting and requires a way to recirculate air back into room which must be created by the installer

INSTALLATION

- Diagram [p.228]

CEILING HOODS WITH BUILT-IN MOTORS



OPTIONAL PLASMA

CE1122SS



OPTIONAL PLASMA

CE1122WH

IMAGE SHOWING RECESSED FITTING OPTION

PRODUCT CODE

Stainless Steel CE1122SS
White CE1122WH

DIMENSIONS

w:1100mm

PERFORMANCE

Energy class A
Light efficiency B
Grease absorption F
Max. extraction 753m³/h [boost]
Max. noise level 62dB[A]

FINISH AVAILABLE

Stainless Steel
White Glass

FEATURES

- Motor included
- Remote control included
- Perimetrical extraction for reduced noise and increased pressure resulting in improved motor performance
- 4 Speeds
- 2 x 9W LED strip lights with dimmer function
- Auto timer, switch-off after 10mins
- Aluminium grease filters
- Ducting spigot size 150mm

OPTIONAL EXTRAS

- Plasma filter [GUC1314]
Note: must be connected to ducting and requires a way to recirculate air back into room which must be created by the installer
- Recirculation kit [CAP64CF]

INSTALLATION

- Diagram [p.228]
- Venting Kits [p.136]

CEILING HOOD



OPTIONAL PLASMA

PRODUCT CODE

CE921WH

DIMENSIONS

w:900mm

PERFORMANCE

Energy class A++ - C
For energy and performance see p.110 - 113

FINISH AVAILABLE

White Glass with
Stainless Steel

FEATURES

- Flush fit
- Slimline body for reduced installation height
- Remote control included
- Perimetrical extraction for reduced noise and increased pressure resulting in improved motor performance

VENTING

Ensure you purchase the correct venting for your Caple extractor. For the full range please see p.136 - 137.

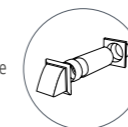

- 4 Speeds
- 3 x 2.5W LED lights [dimnable]
- Auto timer, switch-off after 10mins
- Aluminium grease filters
- Ducting spigot size 150mm
- Ducted only installation
- Motor not included

MOTOR CHOICES

- Plasma filter [GUC1314]
Note: must be connected to ducting and requires a way to recirculate air back into room which must be created by the installer
- Ceiling extractors will need to be purchased with a motor. For the full range please see p.108 - 109.

INSTALLATION

- Diagram [p.228]
- Venting Kits [p.136]

CEILING HOODS



OPTIONAL PLASMA

CE903SS



OPTIONAL PLASMA

CE903WH

PRODUCT CODE

Stainless Steel CE903SS
White CE903WH

DIMENSIONS

w:900mm

PERFORMANCE

Energy class A++ - B
For energy and performance see p.110 - 113

FINISH AVAILABLE

Stainless Steel
White Glass

FEATURES

- Top or side ducting
- Remote control included
- Perimetrical extraction for reduced noise and increased pressure resulting in improved motor performance

FEATURES

ADJUSTABLE LIGHTS

Customise and coordinate the LEDs with your existing room lighting by adjusting from Warm to Cool White.

- 4 Speeds [inc. Boost function]
- 2 x 7.5W LED's [dimnable]
- Adjustable light temperature [from warm to cool]
- Auto timer, switch-off after 10mins
- Aluminium grease filters
- Required ducting size 150mm-200mm
- Ducted only installation
- Motor not included

MOTOR CHOICES

- Plasma filter [GUC1314]
Note: must be connected to ducting and requires a way to recirculate air back into room which must be created by the installer
- Ceiling extractors will need to be purchased with a motor. For the full range please see p.108 - 109.

INSTALLATION

- Diagram [p.228]
- Venting Kits [p.136]

Extraction Motors.



PRODUCT CODE

DDMEXT11

PERFORMANCE

e For performance see p.110 - 113

FEATURES

- Motor for use with Caple downdraft extractors only [cannot be used with Caple ceiling hoods]
- For installation in cabinet fixing directly to the downdraft body
- Aluminium die-cast construction
- Required ducting size 150mm 

OPTIONAL EXTRAS

- Plasma filter [GUC1314]

INSTALLATION

- Diagram [p.229]
- Venting Kits [p.136]

OPTIONAL PLASMA

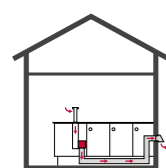

DDMEXT11 WITH DOWNDRAFT

PRODUCT CODE

DDMEXT21

PERFORMANCE

e For performance see p.110 - 113

FEATURES

- Motor for use with Caple downdraft or ceiling extractors
- For installation in ceiling cavity or floor space
- 7m long electrical connection cable [allowing motor installation up to 7m from the extractor]
- Aluminium die-cast construction
- Required ducting size 150mm 
- Rigid ducting must be used

INSTALLATION

- Diagram [p.229]
- Venting Kits [p.136]

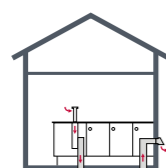

DDMEXT21 WITH DOWNDRAFT

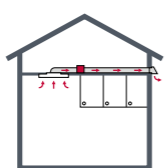

DDMEXT21 FOR CEILING

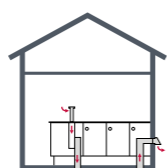

DDMEXT25 WITH DOWNDRAFT

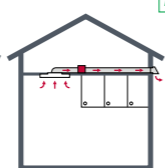

DDMEXT25 FOR CEILING

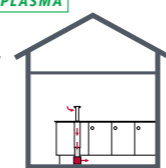

DDMEXT28 WITH DOWNDRAFT

DUE TO THE POWER AND FITMENT OF OUR EXTERNAL MOTORS, RIGID DUCTING MUST BE USED.

PRODUCT CODE

DDMEXT28

PERFORMANCE

e For performance see p.110 - 113

FEATURES

- Motor for use with Caple downdraft extractors only [cannot be used with Caple ceiling hoods]
- For easy installation behind the plinth
- Aluminium die-cast construction
- Required ducting size 150mm 
- Rigid ducting must be used
- To be used in recirculation mode only [recirculation kit required, p.136 - 137]

OPTIONAL EXTRAS

- Plasma filter [GUC1314]

INSTALLATION

- Diagram [p.229]

OPTIONAL PLASMA



PRODUCT CODE

DDMEXT31

PERFORMANCE

e For performance see p.110 - 113

FEATURES

- Motor for use with Caple downdraft or ceiling extractors
- For installation on outside wall
- 7m long electrical connection cable [allowing motor installation up to 7m from the extractor]
- Stainless Steel die-cast construction
- Required ducting size 150mm 
- Rigid ducting must be used

INSTALLATION

- Diagram [p.229]
- Venting Kits [p.136]

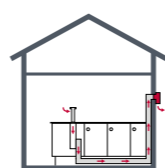

DDMEXT31 WITH DOWNDRAFT

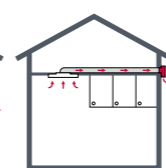

DDMEXT31 FOR CEILING



PRODUCT CODE

DDMEXT40

PERFORMANCE

e For performance see p.110 - 113

FEATURES

- Motor for use with Caple downdraft or ceiling extractors
- For installation on outside wall
- 7m long electrical connection cable [allowing motor installation up to 7m from the extractor]
- Stainless Steel die-cast construction
- Required ducting size 150/200mm 
- Rigid ducting must be used

INSTALLATION

- Diagram [p.229]
- Venting Kits [p.136]

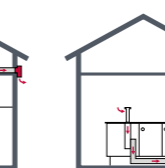

DDMEXT40 WITH DOWNDRAFT

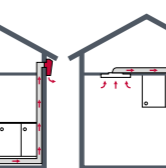

DDMEXT40 FOR CEILING

DUE TO THE POWER AND FITMENT OF OUR EXTERNAL MOTORS, RIGID DUCTING MUST BE USED.

MOTOR PERFORMANCE

You can choose from an extensive range of Caple motors to go with your extractor.

To help you decide which motor suits your needs this table shows the motor combinations and the specific associated performance levels.

If you require further information please contact us directly.

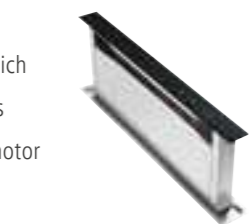

PRODUCT CODE	MOTOR CHOICE	DUCTING OUTLET SIZE [MM]
DOWNDRAFTS		
DD912BK	DDMEXT11	150
	DDMEXT21	150
	DDMEXT25	150
	DDMEXT25	200
	DDMEXT28	150
	DDMEXT31	150
	DDMEXT40	150
DD901BK	DDMEXT11	150
	DDMEXT21	150
	DDMEXT28	150
	DDMEXT31	150
DD606BK	DDMEXT11	150
	DDMEXT21	150
	DDMEXT25	150
	DDMEXT25	200
	DDMEXT28	150
	DDMEXT31	150
	DDMEXT40	150
DD522BK	DDMEXT21	150
	DDMEXT28	150
	DDMEXT31	150
	DDMEXT40	150
DD925C0	DDMEXT11	150
	DDMEXT21	150
	DDMEXT25	150
	DDMEXT28	150
	DDMEXT31	150
DD903BK	DDMEXT21	150
	DDMEXT28	150
	DDMEXT31	150

ENERGY CLASS	EXTRACTION RATE [m3/h]	FLUID DYNAMIC EFFICIENCY	LIGHT EFFICIENCY	GREASE ABSORPTION	NOISE LEVEL DB[A]	ANNUAL CONSUMPTION [kWh/yr]
e						
DOWNDRAFTS						
A	757	A	A	E	61	45
B	682	A	A	E	51	55
C	753	B	A	F	60	103
B	938	B	A	F	50	96
C	530	C	A	E	61	54
C	735	C	A	E	58	97
A+	1142	A	A	F	58	109
A+	1328	A	A	F	60	113
B	681	B	F	E	61	60
B	633	B	F	E	51	55
C	478	C	F	E	70	58
B	730	A	F	E	57	68
A	636	A	-	E	69	46
A	595	B	-	E	66	45
C	622	C	-	E	70	101
B	825	B	-	E	63	91
B	478	C	-	E	67	52
C	597	C	-	E	68	91
B	1110	A	-	E	64	130
B	1210	A	-	E	66	139
A	618	A	-	C	66	48
C	493	D	-	C	70	60
B	638	B	-	D	68	84
B	970	A	-	F	63	147
A	690	A	C	C	61	51
A	660	A	-	C	51	49
C	775	C	C	C	60	109
C	525	D	C	C	61	66
B	700	B	C	C	58	84
A	600	B	-	C	66	48
B	484	C	-	C	70	52
B	700	A	-	D	66	64

MOTOR PERFORMANCE



PRODUCT CODE	MOTOR CHOICE	DUCTING OUTLET SIZE [MM]
CEILING HOODS		
CE903SS & CE903WH	DDMEXT21	150
	DDMEXT25	150
	DDMEXT25	200
	DDMEXT31	150
	DDMEXT40	150
	DDMEXT40	200
CE921WH	DDMEXT21	150
	DDMEXT31	150
	DDMEXT40	150
	DDMEXT40	200

ENERGY CLASS	EXTRACTION RATE [m3/h]	FLUID DYNAMIC EFFICIENCY	LIGHT EFFICIENCY	GREASE ABSORPTION	NOISE LEVEL DB[A]	ANNUAL CONSUMPTION [kWh/yr]
e						
CEILING HOODS						
B	670	B	B	F	44	59
B	900	B	B	F	42	93
B	965	A	B	F	46	95
B	800	B	B	F	47	84
A+	1490	A	B	F	67	98
A++	1575	A	B	F	69	85
B	665	A	A	F	58	55
C	738	C	A	F	61	100
A+	1464	A	A	F	69	98
A++	1543	A	A	F	71	85



Island Hoods.

High quality, highly efficient and intuitive our range of island hoods offer every kind of style to suit your kitchen.

COMPLETE CONTROL

Power and lighting adjustments at your fingertips with our user-friendly remote control. The handy timer function automatically switches off the extractor after 10 minutes, so you can leave your kitchen knowing any odours will have disappeared when you return - just some of the features from our fabulous island hood range.

Vela

With an attractive halo LED light, the Vela hood collection is perfect for making a strong style statement, and is available in Black, Copper or Gold.



PRODUCT CODE

Black	VEL410BK
Copper	VEL410CO
Gold	VEL410GD

DIMENSIONS

↔ w:410mm

PERFORMANCE

e Max. Extraction 456m³/h
Max. Noise level 64dB[A]

FINISH AVAILABLE

- Black
- Copper
- Gold

FEATURES

- Touch control
- Remote control included
- LED ring light
- 3 speeds
- Aluminium grease filter
- Recirculation only
- Recirculation kit included
- Adjustable height allows for both standard and tall ceilings

OPTIONAL EXTRAS

- Replacement recirculation kit [CAP82CF]
- Visit caple.co.uk for full range

INSTALLATION

- Diagram [p.229]

FEATURES

HALO LED LIGHT



REMOTE CONTROL INCLUDED



Ceramica

The Ceramica island hood with its incredibly eye-catching handmade ceramic body, features powerful extraction and exquisite attention to detail.



CR700

CR700SL

CR700WH

PRODUCT CODE

Copper	CR700
Silver	CR700SL
White	CR700WH

DIMENSIONS

w:690mm

PERFORMANCE

Max. Extraction 550m³/h
Max. Noise level 65dB[A]

FINISH AVAILABLE

- Copper
- Silver
- White

FEATURES

- Handmade ceramic body with Stainless Steel filter
- Remote control included
- 4 Speeds
- 20W LED light
- Auto timer, switch-off after 10mins
- Stainless Steel washable grease filter
- Recirculation only installation [supplied with washable recirculation kit]

OPTIONAL EXTRAS

- Replacement washable recirculation kit [CAP58CF]
Visit caple.co.uk for full range

INSTALLATION

- Diagram [p.229]

FEATURES

REMOTE CONTROL INCLUDED



Tela

This ultra-modern Black/smoked glass cooker hood is available with or without a matching shelf. Measuring in at 900mm wide, it is the perfect finishing piece for any contemporary home.

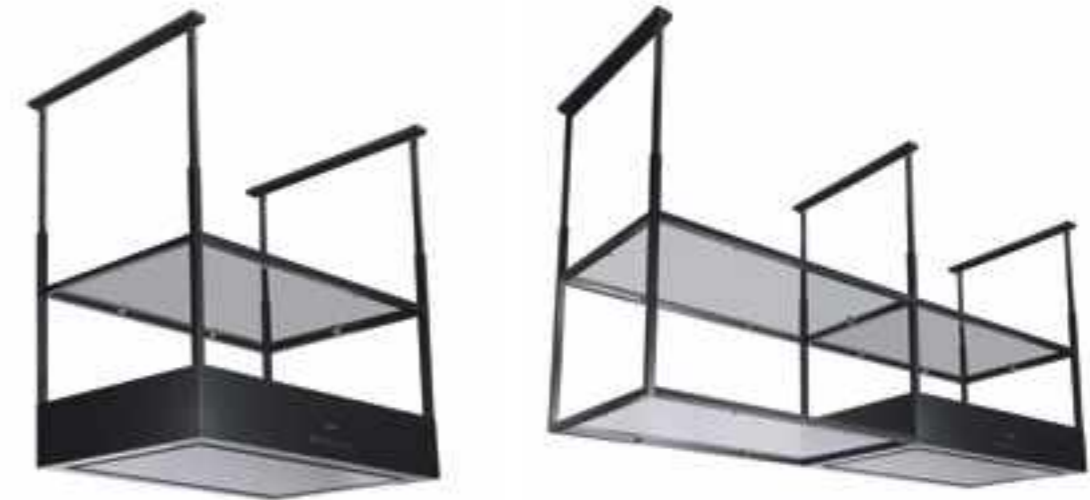

TEL900

TEL900/SHELF

PRODUCT CODE

TEL900

DIMENSIONS

w:900mm

PERFORMANCE

Max. Extraction 550m³/h
Max. Noise level 50dB[A]

FINISH AVAILABLE

- Black with smoked glass shelves

FEATURES

- Touch control
- 2 x 4W LED lights [dimnable]
- Adjustable light temperature [from warm to cool]
- 4 speeds
- Aluminium grease filter
- Recirculation only
- Perimetrical extraction
- Anti-Condensation system
- Auto timer, switch off after 10mins
- Motor included
- Regeneratable charcoal filter included

OPTIONAL EXTRAS

- Replacement recirculation kit [CAP86CF]
- TEL900/SHELF
Visit caple.co.uk for full range

INSTALLATION

- Diagram [p.230]

PRODUCT CODE

TEL900/SHELF

DIMENSIONS

w:900mm

FINISH AVAILABLE

- Black with smoked glass shelves

FEATURES

- Shelf unit designed for use with TEL900 Island Hood
- Shelf unit can be mounted left or right hand side of TEL900 extractor

INSTALLATION

- Diagram [p.230]

FEATURES

ADJUSTABLE LIGHTS

Customise and coordinate the LEDs with your existing room lighting by adjusting from Warm to Cool white.

ANTI-CONDENSATION SYSTEM

An innovative anti-condensation system based on thermal resistance inside the glass panel. By heating the surface in contact with steam coming up from the induction hob, this system helps to prevent condensation/water drops falling onto the hob below.

ISLAND HOOD



PRODUCT CODE

OI363

DIMENSIONS

↔ w:362mm

PERFORMANCE

e Energy class A
 Fluid dynamic efficiency A
 Light efficiency A
 Grease absorption D
 Annual Consumption 44kWh/yr
 Max. extraction 730m³/h [Boost]
 Max. noise level 64dB[A]

FINISH AVAILABLE

■ Stainless Steel

FEATURES

REMOTE CONTROL INCLUDED



FEATURES

- Remote control included
- 4 Speeds [inc. Boost setting]
- 1 x 4W high intensity LED light
- Auto timer, switch-off after 10mins
- Aluminium grease filter
- Required ducting size 150mm
- Recirculation kit available

OPTIONAL EXTRAS

- Recirculation kit [CAP38CF]
 Visit caple.co.uk for full range

INSTALLATION

- Diagram [p.229]
- Venting Kits [p.136]

ISLAND HOOD



OPTIONAL PLASMA

PRODUCT CODE

BXi911

DIMENSIONS

↔ w:900mm

PERFORMANCE

e Energy class D
 Fluid dynamic efficiency D
 Light efficiency D
 Grease absorption D
 Annual Consumption 96kWh/yr
 Max. extraction 605m³/h
 Max. noise level 69dB[A]

FINISH AVAILABLE

■ Stainless Steel

FEATURES

- Touch controls
- 3 Speeds
- 4 x 1.5W high intensity LED lights
- Aluminium grease filters
- Required ducting size 150mm
- Supplied with 2m length of semi-rigid ducting
- Recirculation kit available

OPTIONAL EXTRAS

- Plasma filter [GUC1212]
- Recirculation kit [CAP61CF]
 Visit caple.co.uk for full range

INSTALLATION

- Diagram [p.230]
- Venting Kits [p.136]

ISLAND HOOD



OPTIONAL PLASMA

PRODUCT CODE

Zi922

DIMENSIONS

↔ w:900mm

PERFORMANCE

e Energy class B
 Fluid dynamic efficiency B
 Light efficiency A
 Grease absorption D
 Annual Consumption 54kWh/yr
 Max. extraction 581m³/h
 Max. noise level 66dB[A]

FINISH AVAILABLE

■ Stainless Steel with a Black Glass front panel

VENTING

Ensure you purchase the correct venting for your Caple extractor. For the full range please see p.136 - 137.

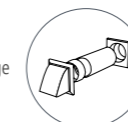

FEATURES

- Illuminated LED touch controls front and back
- 3 Speeds
- Large LED light panel
- Aluminium grease filters
- Required ducting size 150mm
- Recirculation kit available

OPTIONAL EXTRAS

- Plasma filter [GUC1212]
- Recirculation kit [CAP61CF]
 Visit caple.co.uk for full range

INSTALLATION

- Diagram [p.230]
- Venting Kits [p.136]

ISLAND HOOD/REDUCED CEILING HEIGHT ISLAND HOOD



CGi920/RED Suitable for a 2.3m ceiling height
 600-910 mm

PRODUCT CODE

CGi921
 CGi920/RED [Reduced ceiling height]

DIMENSIONS

↔ w:900mm
 h:920-1240mm CGi921
 h:600-910mm CGi920/RED

CGi921 PERFORMANCE

e Energy class A
 Fluid dynamic efficiency A
 Light efficiency C
 Grease absorption D
 Annual Consumption 42kWh/yr
 Max. extraction 617m³/h
 Max. noise level 68dB[A]

CGi920/RED PERFORMANCE

e Energy class D
 Fluid dynamic efficiency D
 Light efficiency C
 Grease absorption D
 Annual Consumption 96kWh/yr
 Max. extraction 608m³/h
 Max. noise level 69dB[A]

FINISH AVAILABLE

■ Stainless Steel with curved clear glass

FEATURES

- Touch controls [CGi921]
- Electronic controls [CGi920/RED]
- 3 Speeds
- 4 x 1.5W high intensity LED lights
- Aluminium grease filters
- Required ducting size 150mm
- Supplied with 2m length of semi-rigid ducting
- Recirculation kit available

OPTIONAL EXTRAS

- Plasma filter [GUC1214 - CGi921]
- Plasma filter [GUC1212 - CGi920/RED]
- Recirculation kit [CAP61CF]
 Visit caple.co.uk for full range

INSTALLATION

- Diagram [p.230]
- Venting Kits [p.136]



Wall Chimney Hoods.

Our practical and stylish chimney hoods are sure to make a statement. Multi-functional and great to look at extraction will be a joy when you cook.

PYRA

Experience unparalleled sophistication with the PYR600. Its striking pyramid design, meticulously crafted in ceramic, showcases precision and elegance. Elevate your style with this unique piece that stands out in any space.



PRODUCT CODE

PYR600

DIMENSIONS

↔ w:600mm

PERFORMANCE

e Energy class A
 Fluid Dynamic Efficiency A
 Light Efficiency A
 Grease Absorption C
 Annual Consumption
 48kWh/yr
 Max. extraction 610m³/h
 Max. noise level 64dB[A]

FINISH AVAILABLE

■ Black

FEATURES

- Handmade ceramic front panel
- Electronic push controls
- 4 speeds
- 2 x 3.75W LED lights
- Dimmable lights
- Adjustable light temperature [from cool to warm]
- Aluminium grease filter
- Top or back duct connection
- Ducting spigot size 150mm 
- Recirculation kit available
- Auto timer, switch off after 10mins
- Can be installed with or without the flue section

OPTIONAL EXTRAS

- Recirculation kit [CAP47CF]
 Visit caple.co.uk for full range

INSTALLATION

- Diagram [p.230]
- Venting Kits [p.136]

FEATURES

STRIKING PYRAMID DESIGN

Crafted with precision, the face of the PYR600 boasts a unique pyramid design, meticulously handmade in ceramic for a touch of elegance.

FLEXIBLE INSTALLATION OPTIONS

Adapt to your space with ease - the PYR600 can be installed with or without the flue section. Take advantage of the innovative feature allowing the hood to be extracted from either the top or rear for added convenience.

CUSTOMISABLE ILLUMINATION

Experience versatility with the dimmable and colour-changing LED light, allowing you to set the perfect ambience for any occasion.



Zella

The unique Black or Gunmetal aluminium wings frame a beautifully smooth sheet of sleek Black Glass. The minimal styling and touch control are perfect for creating an ultra-modern look.



ZEL900GM

ZEL900

PRODUCT CODE

ZEL900GM
ZEL900

DIMENSIONS

↔ w:900mm

PERFORMANCE

e Energy class A
Fluid Dynamic Efficiency A
Light Efficiency C
Grease Absorption D
Annual Consumption
43kWh/yr
Max. extraction 612m³/h
Max. noise level 66dB[A]

FINISH AVAILABLE

Gunmetal and Black Glass
 Black Glass and aluminium

FEATURES

- Illuminated LED touch control
- 3 Speeds
- 2 x 1.5W LED lights
- Aluminium grease filters
- Required ducting size 150mm
- Recirculation kit available

OPTIONAL EXTRAS

- Recirculation kit [CAP61CF]
Visit caple.co.uk for full range

INSTALLATION

- Diagram [p.231]
- Venting Kits [p.136]



VENTING

Ensure you purchase the correct venting for your Caple extractor. For the full range please see p.136 - 137.

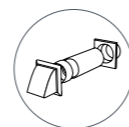

Atara

It's not just the precision engineering and powerful functionality that makes Atara such an impressive extractor. It's the considered design of Black Glass with a discreet Stainless Steel trim which complements the equally satisfying aesthetic of Sense cooking.



PRODUCT CODE

ATA901

DIMENSIONS

↔ w:900mm

PERFORMANCE

e Energy class A
Fluid Dynamic Efficiency A
Light Efficiency C
Grease Absorption D
Annual Consumption
42kWh/yr
Max. extraction 612m³/h
Max. noise level 66dB[A]

FINISH AVAILABLE

Black Glass

FEATURES

- Illuminated LED touch controls
- 3 speeds
- 2 x 1.5 LED lights
- Aluminium grease filters
- Ducting spigot size 150mm
- Supplied with 1.5m length of semi-rigid ducting
- Recirculation kit available

OPTIONAL EXTRAS

- Recirculation kit [CAP61CF]
Visit caple.co.uk for full range

INSTALLATION

- Diagram [p.231]
- Venting Kits [p.136]

Zodiac

The light box illuminates the hob below so you can see exactly what your cooking. Combine this with impressive performance and finish it off with simple touch controls, Zodiac hoods are the perfect choice.



ZC922

OPTIONAL
PLASMA

ZC622

OPTIONAL
PLASMA

PRODUCT CODE

ZC922

ZC622

DIMENSIONS

↔	w:900mm	ZC922
↔	w:600mm	ZC622

ZC922 PERFORMANCE

- Energy class B
- Fluid Dynamic Efficiency B
- Light Efficiency A
- Grease Absorption D
- Annual Consumption 45kWh/yr
- Max. extraction 587m³/h
- Max. noise level 66dB[A]

ZC622 PERFORMANCE

- Energy class B
- Fluid Dynamic Efficiency B
- Light Efficiency A
- Grease Absorption D
- Annual Consumption 50kWh/yr
- Max. extraction 570m³/h
- Max. noise level 66dB[A]

FINISH AVAILABLE

- Stainless Steel with Black glass panel

FEATURES

- Illuminated LED touch control
- 3 Speeds
- Large LED light panel
- Aluminium grease filters
- Required ducting size 150mm
- Recirculation kit available

OPTIONAL EXTRAS

- Plasma filter [GUC1212]
- Recirculation kit [CAP61CF]
- Visit caple.co.uk for full range

INSTALLATION

- Diagram [p.231]
- Venting Kits [p.136]

VENTING

Ensure you purchase the correct venting for your Caple extractor. For the full range please see p.136 - 137.

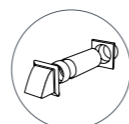

Omnis

The ultra-modern, sleek Black Glass and slanted edges is ideal if you want to create a minimal and stylish look.



OM900

OM600

PRODUCT CODE

OM900

OM600

DIMENSIONS

↔	w:900mm	OM900
↔	w:600mm	OM600

PERFORMANCE

- Energy class C
- Fluid Dynamic Efficiency D
- Light Efficiency B
- Grease Absorption B [OM900]
- C [OM600]
- Annual Consumption 51kWh/yr
- Max. extraction 456m³/h
- Max. noise level 62dB[A]

FINISH AVAILABLE

- Black Glass

FEATURES

- Illuminated LED touch controls
- 3 Speeds
- 2 x 1.5W LED lights
- Aluminium grease filters
- Ducting spigot size 150mm
- Recirculation kit available

OPTIONAL EXTRAS

- Recirculation kit [CAP61CF]
- Visit caple.co.uk for full range

INSTALLATION

- Diagram [p.231]
- Venting Kits [p.136]

VENTING

Ensure you purchase the correct venting for your Caple extractor. For the full range please see p.136 - 137.

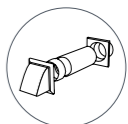

Spirit

Choose from smooth Black with smoked glass or go for stainless steel. What's more, this hood can also work in recirculation mode.



SP912SS

OPTIONAL
PLASMA



SP612SS

OPTIONAL
PLASMA



SP912BK

OPTIONAL
PLASMA



SP612BK

OPTIONAL
PLASMA

PRODUCT CODE

Stainless Steel	SP912SS
Black Glass	SP912BK
Stainless Steel	SP612SS
Black Glass	SP612BK

DIMENSIONS

↔	w:900mm	SP912SS
	w:900mm	SP912BK
	w:600mm	SP612SS
	w:600mm	SP612BK

PERFORMANCE

e	Energy class A
	Fluid Dynamic Efficiency A
	Light Efficiency C [SP912]
	Light Efficiency B [SP612]
	Grease Absorption D
	Annual Consumption 42kWh/yr
	Max. extraction 612m ³ /h
	Max. noise level 66dB[A]

FINISH AVAILABLE

- Stainless Steel with glass panels
- Black with Black glass panels

FEATURES

- Touch controls
- 3 Speeds
- 2 x 1.5W high intensity LED lights
- Aluminium grease filters
- Supplied with 2m length of semi-rigid ducting
- Required ducting size 150mm
- Recirculation kit available

OPTIONAL EXTRAS

- Plasma filter [GUC1214]
 - Recirculation kit [CAP61CF]
- Visit caple.co.uk for full range

INSTALLATION

- Diagram [p.231]
- Venting Kits [p.136]

Classic Hoods.

From understated, classic design to discreet integrated models, whatever you're looking for, we can help.

You'll find a near-endless choice of styles and functionality in the Classic range. Whichever you opt for, you can guarantee it will perform to the highest standards and keep your kitchen free from odours and grease, while powerful halogen or LED lights illuminate the cooking zone below.





WALL CHIMNEY HOODS



FGC920
OPTIONAL PLASMA

FGC720
OPTIONAL PLASMA

FGC621
OPTIONAL PLASMA

PRODUCT CODE

FGC920
FGC720
FGC621

DIMENSIONS

↔	w:895mm	FGC920
	w:695mm	FGC720
	w:595mm	FGC621

FGC920 / FGC720 PERFORMANCE

e Energy class D
Fluid Dynamic Efficiency D
Light Efficiency B
Grease Absorption C
Annual Consumption 95kWh/yr
Max. extraction 580m3/h
Max. noise level 68dB[A]

FGC621 PERFORMANCE

e Energy class B
Fluid Dynamic Efficiency C
Light Efficiency B
Grease Absorption D
Annual Consumption 65kWh/yr
Max. extraction 654m3/h
Max. noise level 67dB[A]

FINISH AVAILABLE

Stainless Steel with flat clear glass

FEATURES

- Touch control [FGC621 only]
- Push button controls [FGC920 and FGC720]
- 3 Speeds
- 2 x 1.5W high intensity LED lights
- Aluminium grease filter
- Required ducting size 150mm
- Supplied with 2m length of semi-rigid ducting
- Recirculation kit available

OPTIONAL EXTRAS

- Plasma filter [GUC1212]
- Recirculation kit [CAP61CF] Visit caple.co.uk for full range

INSTALLATION

- Diagram [p.232]
- Venting Kits [p.136]

FEATURES

Effortlessly manage your kitchen environment with intuitive touch controls on the FGC621, providing direct and precise command over the extractor's functions.

WALL CHIMNEY HOODS



PRODUCT CODE

Stainless Steel	CGC911SS
Black	CGC911BK
Stainless Steel	CGC711SS
Black	CGC711BK
Stainless Steel	CGC611SS
Black	CGC611BK

DIMENSIONS

↔	w:895mm	CGC911SS
	w:895mm	CGC911BK
	w:695mm	CGC711SS
	w:695mm	CGC711BK
	w:595mm	CGC611SS
	w:595mm	CGC611BK

PERFORMANCE

e Energy class C
Fluid Dynamic Efficiency D
Light Efficiency A
Grease Absorption B [CGC911 & CGC711]
Grease Absorption C [CGC611]
Annual Consumption 52kWh/yr
Max. extraction 456m3/h
Max. noise level 56dB[A]

FINISH AVAILABLE

- Stainless Steel with curved clear glass
- Black with curved clear glass

FEATURES

- Push button controls
- 3 Speeds
- 2 x 2W high intensity LED lights
- Aluminium grease filters
- Required ducting size 150mm
- Supplied with 2m length of semi-rigid ducting
- Recirculation kit available

OPTIONAL EXTRAS

- Plasma filter [GUC1212]
- Recirculation kit [CAP75CF] Visit caple.co.uk for full range

INSTALLATION

- Diagram [p.232]
- Venting Kits [p.136]

FEATURES

SPLASHBACK

This unique splashback has been designed to fit perfectly with the curved canopy of the Caple CGC hoods and is available in Black, pewter or Stainless Steel - see p.138.

VENTING CHOICES

Ensure you purchase the correct venting for your Caple extractor. For the full range please see p.136 - 137.

WALL CHIMNEY HOODS



BXC911

OPTIONAL
PLASMA



BXC611

OPTIONAL
PLASMA

PRODUCT CODE

BXC911

BXC611

DIMENSIONS

↔ w:900mm BXC911
↔ w:600mm BXC611

PERFORMANCE

BXC911

e Energy class C
Fluid Dynamic Efficiency D
Light Efficiency C
Grease Absorption D
Annual Consumption
86kWh/yr
Max. extraction 571m³/h
Max. noise level 76dB[A]

BXC611

e Energy class C
Fluid Dynamic Efficiency D
Light Efficiency B
Grease Absorption B
Annual Consumption
50kWh/yr
Max. extraction 456m³/h
Max. noise level 56dB[A]

FINISH AVAILABLE

■ Stainless Steel

FEATURES

- Touch controls
- 3 Speeds
- 2 x 1.5W high intensity LED lights
- Aluminium grease filters
- Required ducting size 150mm
- Recirculation kit available

OPTIONAL EXTRAS

- Plasma filter [GUC1212]
- Recirculation kit [CAP61CF]
Visit caple.co.uk for full range

INSTALLATION

- Diagram [p.232]
- Venting Kits [p.136]

FEATURES

FUNCTION + POWER

The seamlessly crafted Stainless Steel features easy-to-use touch controls to create a stylish focal point in your kitchen.

WALL CHIMNEY HOOD



PRODUCT CODE

AH600BK

DIMENSIONS

↔ w:600mm

PERFORMANCE

e Energy class C
Light Efficiency A
Grease Absorption C
Annual Consumption
38kWh/yr
Max. extraction 280m³/h
Max. noise level 62dB[A]

FINISH AVAILABLE

■ Black painted steel

FEATURES

- Push button controls
- 3 Speeds
- 2 x 2W LED lights
- Aluminium grease filters
- Required ducting size 150mm
- Recirculation kit available

OPTIONAL EXTRAS

- Recirculation kit [CAP60CF]
Visit caple.co.uk for full range

INSTALLATION

- Diagram [p.232]
- Venting Kits [p.136]

FEATURES

SMALL KITCHEN? NO PROBLEM.

AH600BK has been designed for kitchens up to 3.2m x 3.2m [based on 2.7 ceiling height].

WALL CHIMNEY HOODS



CCH101



CCH901SS



CCH901BK



CCH701



CCH601SS



CCH601BK

PRODUCT CODE

Stainless Steel CCH101

Stainless Steel CCH901SS

Black CCH901BK

Stainless Steel CCH701

Stainless Steel CCH601SS

Black CCH601BK

DIMENSIONS

↔ w:1000mm CCH101
↔ w:900mm CCH901SS
↔ w:900mm CCH901BK
↔ w:700mm CCH701
↔ w:600mm CCH601SS
↔ w:600mm CCH601BK

PERFORMANCE

e Energy class C
Fluid Dynamic Efficiency E
Light Efficiency A
Grease Absorption C
Annual Consumption
36kWh/yr [CCH601 & CCH701]
Annual Consumption
37kWh/yr [CCH901 & CCH101]
Max. extraction 305m³/h
Max. noise level 62dB[A]

FINISH AVAILABLE

■ Stainless Steel

■ Black

FEATURES

- Push button controls
- 3 Speeds
- 1 x 2W LED light
- Aluminium grease filters
- Required ducting size 150mm
- Supplied with 2m length of semi-rigid ducting
- Recirculation kit available

OPTIONAL EXTRAS

- Recirculation kit [CAP60CF]
Visit caple.co.uk for full range

INSTALLATION

- Diagram [p.233]
- Venting Kits [p.136]

FEATURES

FUNCTION + POWER

Simple in design, efficient in performance with a choice of two finishes to suit your kitchen.



VENTING CHOICES

Ensure you purchase the correct venting for your Caple extractor. For the full range please see p.136 - 137.

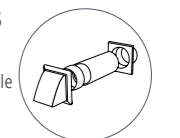

INTEGRATED HOOD



OPTIONAL PLASMA

PRODUCT CODE

INCH

DIMENSIONS

w:600mm

PERFORMANCE

Energy class C
 Fluid Dynamic Efficiency E
 Light Efficiency B
 Grease Absorption D
 Annual Consumption 37kWh/yr
 Max. extraction 329m³/h
 Max. noise level 64dB[A]

FINISH AVAILABLE

Silver Grey

FEATURES

- Slider control
- 3 Speeds
- 2 x 2W LED lights
- Aluminium grease filters
- Ducting spigot size 150mm
- Recirculation kit available

OPTIONAL EXTRAS

- Plasma filter [GUC1212]
- Recirculation kit [CAP73CF]
 Visit caple.co.uk for full range

INSTALLATION

- Diagram [p.233]
- Venting Kits [p.136]

VENTING

Ensure you purchase the correct venting for your Caple extractor. For the full range please see p.136 - 137.

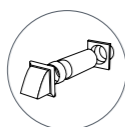

STORM BUILT-UNDER HOODS



ST854

OPTIONAL PLASMA



ST524

OPTIONAL PLASMA

PRODUCT CODE

ST854

ST524

DIMENSIONS

w:850mm	ST854
w:520mm	ST524

ST854 PERFORMANCE

Energy class A
 Fluid Dynamic Efficiency A
 Light Efficiency A
 Grease Absorption A
 Annual Consumption 46kWh/yr
 Max. extraction 743m³/h [boost]
 Max. noise level 63dB[A]

ST524 PERFORMANCE

Energy class A
 Fluid Dynamic Efficiency A
 Light Efficiency A
 Grease Absorption A
 Annual Consumption 45kWh/yr
 Max. extraction 680m³/h [boost]
 Max. noise level 63dB[A]

FINISH AVAILABLE

Stainless Steel

FEATURES

- Electronic push button controls
- ST854: 6W LED light [dimmable]
- ST524: 4W LED light [dimmable]
- Adjustable light temperature [from warm to cool]
- 4 speeds [including boost]
- Stainless Steel baffle filter
- Can be ducted
- Required ducting size 150mm
- Top or back ducting connection
- Can be recirculated
- Auto timer, switch off after 10mins
- Motor included

OPTIONAL EXTRAS

- Plasma filter [GUC1214]
- Recirculation kit for ST854 [CAP65CF - 2 required]
- Recirculation kit for ST524 [CAP54CF - 2 required]
 Visit caple.co.uk for full range

INSTALLATION

- Diagram [p.233 - 234]
- Venting Kits [p.136]

TOUCH CONTROL BUILT-UNDER HOODS



TBU851

OPTIONAL PLASMA



TBU521

OPTIONAL PLASMA

PRODUCT CODE

TBU851

TBU521

DIMENSIONS

w:850mm	TBU851
w:520mm	TBU521

TBU851 PERFORMANCE

Energy class A+
 Fluid Dynamic Efficiency A+
 Light Efficiency A
 Grease Absorption A
 Annual Consumption 42kWh/yr
 Max. extraction 772m³/h [boost]
 Max. noise level 63dB[A]

TBU521 PERFORMANCE

Energy class A
 Fluid Dynamic Efficiency A
 Light Efficiency A
 Grease Absorption A
 Annual Consumption 45kWh/yr
 Max. extraction 680m³/h [boost]
 Max. noise level 63dB[A]

FINISH AVAILABLE

Stainless Steel

FEATURES

- Touch control
- 4 speeds
- TBU851: 6W LED light
- TBU521: 4W LED light
- Adjustable light temperature [from warm to cool]
- Top or back ducting connection
- Can be recirculated
- Auto timer, switch off after 10mins
- Motor included
- Aluminium grease filters
- Required ducting size 150mm
- Recirculation kit available

OPTIONAL EXTRAS

- Plasma filter [GUC1214]
- TBU851 Recirculation kit [CAP42CF - 2 required]
- TBU521 Recirculation kit [CAP78CF]
 Visit caple.co.uk for full range

INSTALLATION

- Diagram [p.234]
- Venting Kits [p.136]

BUILT-UNDER HOOD



OPTIONAL PLASMA

PRODUCT CODE

BU521

DIMENSIONS

w:520mm

PERFORMANCE

Energy class B
 Fluid Dynamic Efficiency B
 Light Efficiency A
 Grease Absorption B
 Annual Consumption 58kWh/yr
 Max. extraction 604m³/h
 Max. noise level 70dB[A]

FINISH AVAILABLE

Stainless Steel

FEATURES

- Push button controls
- 3 Speeds
- 2 x 2.1W high intensity LED light
- Aluminium grease filter
- Required ducting size 150mm
- Recirculation kit available

OPTIONAL EXTRAS

- Plasma filter [GUC1212]
- Recirculation kit [CAP66CF]
 Visit caple.co.uk for full range

INSTALLATION

- Diagram [p.234]
- Venting Kits [p.136]

BUILT-UNDER GLASS HOODS



OPTIONAL
PLASMA



OPTIONAL
PLASMA

PRODUCT CODE

BU525BK
BU755BK

DIMENSIONS

↔ w:520mm BU525BK
↔ w:750mm BU755BK

BU525BK PERFORMANCE

e Energy class B
Fluid Dynamic Efficiency B
Light Efficiency D
Grease Absorption D
Annual Consumption
48.7kWh/yr
Max. extraction
621m³/h [boost]
Max. noise level 66dB[A]

BU755BK PERFORMANCE

e Energy class B
Fluid Dynamic Efficiency A
Light Efficiency E
Grease Absorption D
Annual Consumption
49.9kWh/yr
Max. extraction
657m³/h [boost]
Max. noise level 66dB[A]

FINISH AVAILABLE

■ Black Glass

FEATURES

- Touch control
- 2 x 1.5W LED Lights
- 4 Speeds [inc. Boost function]
- Aluminium grease filter
- Ducting spigot size 150mm
- Recirculation kit available

OPTIONAL EXTRAS

- Plasma filter [GUC1214]
- Recirculation kit [CAP61CF]
Visit caple.co.uk for full range

INSTALLATION

- Diagram [p.234]
- Venting Kits [p.136]

BUILT-UNDER HOODS



OPTIONAL
PLASMA



PRODUCT CODE

BUCH
BUCH75

DIMENSIONS

↔ w:520mm BUCH
↔ w:750mm BUCH75

BUCH PERFORMANCE

e Energy class C
Fluid Dynamic Efficiency E
Light Efficiency B
Grease Absorption D
Annual Consumption
37kWh/yr
Max. extraction 286m³/h
Max. noise level 62dB[A]

BUCH75 PERFORMANCE

e Energy class D
Fluid Dynamic Efficiency A
Light Efficiency B
Grease Absorption D
Annual Consumption
90kWh/yr
Max. extraction 426m³/h
Max. noise level 67dB[A]

FINISH AVAILABLE

■ Stainless Steel

FEATURES

- Slider controls
- 3 Speeds
- 2 x 2W LED lights
- Aluminium grease filters
- Required ducting size 150mm
- Recirculation kit available

OPTIONAL EXTRAS

- Plasma filter for BUCH [GUC1212]
- Recirculation kit for BUCH [CAP73CF]
- Recirculation kit for BUCH75 [CAP85CF]
Visit caple.co.uk for full range

INSTALLATION

- Diagram [p.235]
- Venting Kits [p.136]

BUILT-UNDER TELESCOPIC HOODS



OPTIONAL
PLASMA



OPTIONAL
PLASMA

PRODUCT CODE

TSCH601
TSCH901

DIMENSIONS

↔ w:600mm TSCH601
↔ w:900mm TSCH901

PERFORMANCE

e Energy class C
Fluid Dynamic Efficiency E
Light Efficiency A
Grease Absorption D
Annual Consumption
32kWh/yr
Max. extraction
291.3m³/h
Max. noise level 65dB[A]

FINISH AVAILABLE

■ Stainless Steel fascia with silver grey body

FEATURES

- Rocker switch
- 2 Speeds
- Required ducting size 150mm
- 2 x Aluminium grease filters
- Recirculation kit available

TSCH601 FEATURES

- 1 x 2W LED light

TSCH901 FEATURES

- 2 x 2W LED lights

OPTIONAL EXTRAS

- Plasma filter [GUC1212]
- Recirculation kit [CAP60CF]
Visit caple.co.uk for full range

INSTALLATION

- Diagram [p.235]
- Venting Kits [p.136]

CONVENTIONAL HOOD



OPTIONAL
PLASMA



OPTIONAL
PLASMA

PRODUCT CODE

FSCHSS9

DIMENSIONS

↔ w:600mm

PERFORMANCE

e Energy class B
Fluid Dynamic Efficiency E
Light Efficiency A
Grease Absorption E
Annual Consumption
30kWh/yr
Max. extraction
201.9m³/h
Max. noise level 55dB[A]

FINISH AVAILABLE

■ Stainless Steel

FEATURES

- Push button controls
- 3 Speeds
- 1 x 2W LED light
- Aluminium grease filters
- Required ducting size 120mm
- Recirculation kit available

OPTIONAL EXTRAS

- Recirculation kit [CAP80CF]
Visit caple.co.uk for full range

INSTALLATION

- Diagram [p.235]
- Venting Kits [p.136]

VENTING CHOICES

Ensure you purchase the correct venting for your Caple extractor. For the full range please see p.136 - 137.

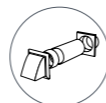

Venting.

To ensure you get the most out of your extraction we have the perfect venting solution to suit your needs.

CHOOSING THE RIGHT VENTING

To ensure you have the correct venting for your chosen hood, please refer to the hood specification where the required diameter kit is listed.

EXTERNAL MOTORS

Due to the power and fitment of Caple external motors [DDMEXT11, DDMEXT21, DDMEXT25, DDMEXT28, DDMEXT31 and DDMEXT40, see p.108 - 109] you must use rigid ducting.

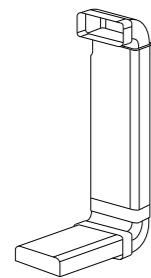

150MM VENTING KIT
[CODE KIT/960W]

Rigid Ducting
[for DD810BK]

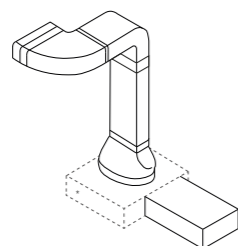

150MM VENTING KIT
[CODE KIT/961W]

Rigid Ducting
[for DD810BK & DD620BK]



150MM VENTING KIT
[CODE C202-6W]

1 Metre flexible venting kit



125MM VENTING KIT
[CODE C227W]

3 Metre venting kit
[for FSCHSS9]



125MM VENTING KIT
[CODE C202-5W]

1 Metre flexible venting kit
[for FSCHSS9]



VENTING GRILLE
[CODE CVGS]

Worktop aluminium vent

COOLING VENTING

When installing integrated refrigeration it is important to use the correct venting.

High Efficiency Venting.

Due to the profile of a duct bend, air travelling through it can become turbulent causing increased resistance and noise. As a consequence the cooker hood will need to work harder in order to meet the required airflow rates, therefore consuming more energy. This high efficiency 90° bend has been designed to allow a uniform flow of air through the section of ducting, reducing the resistance by up to 60% and lowering the air speed. All of which results in a quieter and more efficient system.

- Smoothly channels air through the duct bend in a uniform flow
- Reduced duct resistance by up to 60% to lower the systems pressure drop and overall energy usage
- Reduced air speed through the bend to reduce noise
- Performance has been tested by the Building Research Establishment [BRE]

The diagram illustrates the improvement of air flow when using C550GL or C950GL ducting:

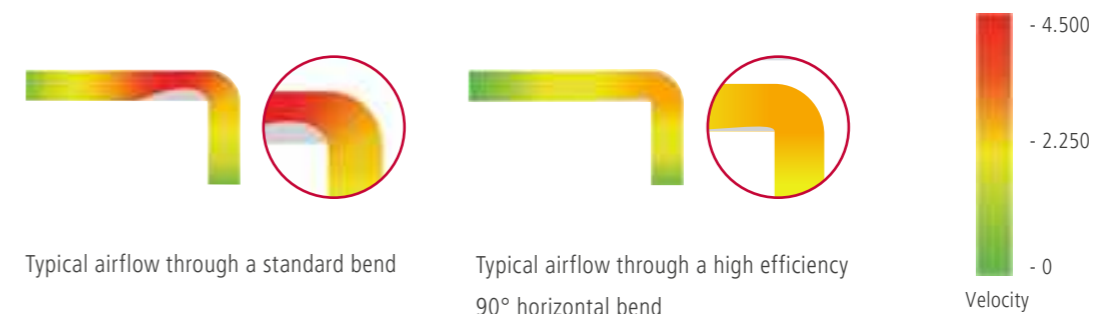

Typical airflow through a standard bend

Typical airflow through a high efficiency 90° horizontal bend

Velocity



125MM ELBOW BEND
[CODE C550GL]

- Suitable for 125mm flat channel ducting [204 x 60mm] Can be used with C227W and 515W



150MM ELBOW BEND
[CODE C950GL]

- Suitable for 150mm flat channel ducting [220 x 90mm] Can be used with C2653WGL, C2655WGL and 915W



150MM VENTING KIT
[CODE C2653WGL]

- For hoods with extraction over 500m³/h
- 3m venting kit



150MM VENTING KIT
[CODE C2655WGL]

- Suitable for use with downdraft hoods
- 3m rigid venting kit

Splashbacks.

The perfect finishing touch.



TOUGHENED GLASS SPLASHBACK



PRODUCT CODE

TSB1000**
[Available in Black and pewter only]

TSB900**

TSB600**

DIMENSIONS

h:750mm	d:5mm
TSB1000	w:1000mm
TSB900	w:900mm
TSB600	w:600mm

FEATURES

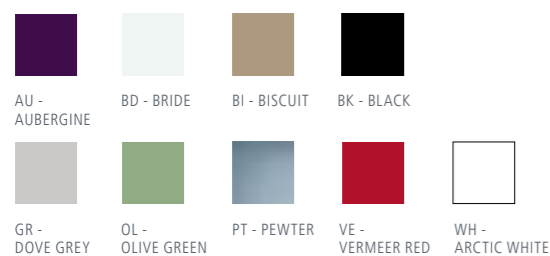

For chosen colour option, replace '' with colour code - see swatches above.

- 9 Colours available
- Will not mark with fingerprints
- Adhesive backed for quick and easy DIY installation [no unsightly fixing screws]
- Toughened glass
- Conforms to BS EN12150:1 British Safety Standards
- Hygienic
- Opaque colour finish
- Can be applied to all flat non-porous, clean surfaces

CURVED TOUGHENED GLASS SPLASHBACK



PRODUCT CODE

TSBCURVE900**

TSBCURVE700**

TSBCURVE600**

DIMENSIONS

h:750mm d:5mm

TSBCURVE900**w:895mm
[Fits CGC911 pg.129]
TSBCURVE700**w:695mm
[Fits CGC711 pg.129]
TSBCURVE600**w:595mm
[Fits CGC611 pg.129]

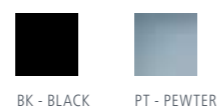

For chosen colour option, replace '' with colour code - see swatches above.

FEATURES

SAFE + EASY TO INSTALL

All Caple glass splashbacks are adhesive-backed. This stops them shattering and allows fitting to any clean, non-porous surface. All our glass products meet British Safety Standards and are made from toughened glass.



COLOURS ARE ONLY A GUIDE. GLASS SAMPLE PACKS ARE AVAILABLE TO ORDER [CODE TSB/SAMP9]

STAINLESS STEEL SPLASHBACK



PRODUCT CODE

CSB1006

CSB906

CSB706

CSB606

DIMENSIONS

h:750mm	d:10.5mm
CSB1006	w:1000mm
CSB906	w:900mm
CSB706	w:700mm
CSB606	w:600mm



STAINLESS STEEL

CURVED STAINLESS STEEL SPLASHBACK



PRODUCT CODE

CSBCURVE905

CSBCURVE705

CSBCURVE605

DIMENSIONS

h:750mm	d:10.5mm
CSBCURVE905	w:900mm [Fits CGC911 pg.129]
CSBCURVE705	w:700mm [Fits CGC711 pg.129]
CSBCURVE605	w:600mm [Fits CGC611 pg.129]



STAINLESS STEEL



Cooling.

FREESTANDING REFRIGERATION	147
INTEGRATED REFRIGERATION	152
WINE CABINETS	164

Refrigeration.

Chill it, freeze it, love it.

Whether you want a discreet space-saving under-counter fridge or something more spacious, you'll find it right here.



Whatever you want, that's cool.

We've one for every kind of kitchen, big or small. Different colours, different finishes, different sizes and plenty of functionality.



FRENCH DOOR

This large, freestanding fridge freezer has two doors on the top for the fridge and drawers or doors underneath for the freezer, great for storing large items.

70/30 FREESTANDING

This is the perfect option when space is key. This stacked refrigeration solution allows you to keep that extra floor space with the impressive styling of freestanding refrigeration.

INTEGRATED

Our fridge freezer combinations or compact under-counter and in-column products can be hidden behind furniture doors. Choose fridges and freezers in different sizes and combinations depending on the space available and where you want to put them in your kitchen.

Freestanding Refrigeration.

Discover convenience, storage, and simplicity with our freestanding fridge freezers. Ready to use without installation, they're perfect for limited spaces. Caple freestanding fridges combine spacious compartments, durable glass shelves, and well-organised freezer drawers for effortless storage.



TELESCOPIC RUNNERS

The full extension telescopic runners make it easy to quickly pack away shopping, as well as allow for effortless and smooth access to the very back of your fridge-freezer drawers.



INTERNAL LED LIGHTING + TOUCH CONTROLS

Bold, well positioned LED lighting illuminate the interior of the fridge for excellent visibility while the touch controls provide quick access to all the handy functions.



FULL ILLUMINATION

The stylish backlight takes centre stage illuminating the entire fridge from top to bottom ensuring you can see all your fridge's contents quickly and easily.



STEEL TRIMMED INTERIOR

When it comes to quality, it's the small details that can make a big difference. The steel trim adds to the premium aesthetic of our American refrigeration.



DOUBLE UP

Two freezer drawers gives you easy access to your food and with the capacity of 211L, the CAFF43 can freeze all your tasty treats until you need them.

FRENCH DOOR FRIDGE FREEZER



PRODUCT CODE

CAFF43

DIMENSIONS

h:1850mm
w:910mm
d:775mm
[inc. door - excl. handle]
d:825mm
[inc. door and handle]

PERFORMANCE

e Energy class E
Noise class C
Energy consumption
336kWh/yr
Max. noise level 39dB[A]
Freezing Capacity
13kg/24hrs

FINISH AVAILABLE

Stainless Steel

FEATURES

- Super Freeze and Super Cool functions
- Electronic touch control with LED display
- 4 Star freezer
- Frost-free
- Independent temperature control for the fridge and freezer zones
- Open door alarm
- Holiday mode
- Eco mode
- Energy saving display option
- Drink cooling mode
- Caple Cool air-flow system
- Multi-air flow design in fridge and freezer compartments
- Self closing meat chiller compartment
- Child lock
- 100% CFC / HFC free
- Enhanced energy saving LED lighting

DESIGN

- Stainless Steel doors with grey cabinet
- Metal handles
- Steel trimmed interior
- Metal back
- Telescopic runners

FRIDGE STORAGE

- 2 Spill-capture adjustable glass shelves
- 1 Spill-proof chiller cover shelf
- 2 humidity controlled drawers
- 1 Meat chiller compartment
- 2 Covered dairy compartments
- 6 Door storage racks
- 2 Egg storage trays

FREEZER STORAGE

- 3 Drawers and 2 compartments
- 2 Ice cube trays

CAPACITY

- 398 Litre fridge net capacity
- 211 Litre freezer net capacity

INSTALLATION

- Diagram [p.236]

FREESTANDING 70/30 FRIDGE FREEZER



FEATURES

CAPLE COOL

The fan positioned at the top of the fridge circulates the cool air for even distribution keeping your food at the perfect temperature. Help preserve fresh foods for longer by adjusting the humidity in the crisper compartments.

PRODUCT CODE

RFF732

DIMENSIONS

h: 1860mm
w: 595mm
d: 650mm
[inc. door - excl. handle]

PERFORMANCE

e Energy class E
Noise class C
Annual energy consumption
250kWh/yr
Max. noise level 39dB[A]
Freezing capacity
8kg/24hrs

FINISH AVAILABLE

Stainless Steel

GENERAL FEATURES

- Touch control
- Energy saving display option
- Deluxe steel trimmed interior
- Easy to use control panel
- Independent temperature control for the fridge and freezer zones
- Right hand hinged door*
- Child lock
- Holiday mode
- Eco mode
- Energy saving display option
- Caple Cool air-flow system
- Metal handles
- High temperature alarm
- Open door audible alarm
- Independent temperature control for the fridge and freezer zones

FRIDGE FEATURES

- Auto defrost
- Interior LED light
- Super Cool
- Caple Cool air-flow system
- Humidity controlled fruit and veg drawer
- Wine rack

FREEZER FEATURES

- 4 star
- Frost-free
- Super freeze
- Drink cooling mode

STORAGE

- 2 Removable glass shelves
- 1 Salad crisper
- 1 Glass crisper cover shelf
- 1 Humidity controlled drawer
- 1 Wine rack
- 3 Standard door balconies
- 1 Egg tray
- 3 Freezer drawers
- 1 ice cube tray

CAPACITY

- 101 Litre net freezer capacity
- 230 Litre net fridge capacity

INSTALLATION

- Diagram [p.237]

* The door is supplied RH hinged, it can be reversed. Please consult a qualified installation expert to reverse door configuration.

Integrated Refrigeration.

When it comes to integrated appliances, It's what's on the inside that counts. If you are looking for clean, discreet installation our refrigeration offers just that. Seamless door-on-door fitting coupled with intuitive functionality takes our integrated refrigeration to another level of cool.



STEEL DOORS

The Stainless Steel door [SSDOOR177DOD] has been designed to work alongside selected refrigeration.



DISCREET INSTALLATION

Selected integrated models feature door-on-door installation. The fridge hinges attach directly onto the furniture door, so the fridge fixings are hidden for a discreet appearance.



DON'T FORGET YOUR VENTING GRILLE

Remember, it's important to vent your cooling products. Not only does it preserve the product's life, it also improves efficiency for day-to-day usage. Choose an integrated plinth grille for a discreet solution to venting correctly.



IN-COLUMN LARDER FRIDGE



PRODUCT CODE

RiL1800

DIMENSIONS

h:1770mm

PERFORMANCE

Energy class E
Noise class C
Energy consumption
112kWh/yr
Max. noise 39dB

FINISH AVAILABLE

White

GENERAL FEATURES

- Matches RIF1801 freezer
- Door on door installation
- Eco Mode
- Reversible door
- Touch controls
- High temperature warning
- Open door audible alarm
- Top and side LED strip lights
- Super Cool
- Caple Cool air-flow system
- Caple Fresh

DESIGN

- Deluxe steel trimmed interior
- Transparent plastic drawers and compartments

STORAGE

- 4 Removable glass shelves
- 1 Easy adjustable door balcony
- 4 Standard door balconies
- 1 Egg tray
- Wine rack
- 1 Humidity controlled drawer
- 2 Crisper drawers
- 1 Crisper cover shelf

CAPACITY

- 294 Litre net capacity

INSTALLATION

- Diagram [p.238]

FEATURES

FRUIT + VEGETABLE PRESERVATION

The Caple Fresh preservation technology inside the crisper drawer, ensures that your fruit and vegetables stay fresher and tastier for longer. This innovative new system helps to eliminate the natural gases that are produced during the ripening and ageing process, preserving them for longer.

Also, the Caple Fresh preserver does not need to be replaced. It can be regenerated by exposing it to sunlight for one day a year.



COOLING TRIO

Our RiF1801 & RiL1800 in-column refrigeration models have been designed to complement our WC1801 wine cabinet, so you can create a luxurious cooling trio.



70/30 FRIDGE FREEZER - FROST-FREE



PRODUCT CODE

Ri7321

DIMENSIONS

h:1770mm

PERFORMANCE

e Energy class E
Noise class C
Energy consumption
218kWh/yr
Max. noise 41dB
3.3kg/24hr freezing
capacity

FINISH AVAILABLE

White

GENERAL FEATURES

- Reversible door
- Door on door installation
- Touch controls
- High temperature warning
- Open door audible alarm
- Eco mode
- Holiday mode
- Drink Cooling Mode

FRIDGE FEATURES

- Auto defrost
- Top and side LED strip lights
- Super Cool
- Caple Cool air-flow system
- Caple Fresh

FREEZER FEATURES

- 4 star
- Frost-free
- Super freeze
- Ice cube tray

DESIGN

- Deluxe steel trimmed interior
- Transparent plastic drawers and compartments

FRIDGE STORAGE

- 3 Removable glass shelves
- 1 Easy adjustable door balcony
- 3 Standard door balconies
- 1 Egg tray
- Wine rack
- 1 Humidity controlled drawer
- 1 Cover shelf

FREEZER STORAGE

- 2 Freezer drawers
- 1 Sliding tray

CAPACITY

- 180 Litre fridge net capacity
- 63 Litre freezer net capacity

INSTALLATION

- Diagram [p.238]

IN-COLUMN FREEZER - FROST-FREE



PRODUCT CODE

RiF1801

DIMENSIONS

h:1770mm

PERFORMANCE

e Energy class E
Noise class C
Energy consumption
231kWh/yr
Max. noise 40dB
11.5kg/24hr freezing
capacity

FINISH AVAILABLE

White

GENERAL FEATURES

- Matches RIL1800 larder fridge
- Door on door installation
- Reversible door
- Touch controls
- High temperature warning
- Open door audible alarm
- 4 star
- Frost Free
- Eco mode
- Top LED strip light
- Super freeze
- 1 Twist ice cube maker

DESIGN

- Deluxe steel trimmed interior
- Transparent plastic drawers and compartments

STORAGE

- 6 Drawers
- 2 flip down door compartments

CAPACITY

- 197 Litre net capacity

INSTALLATION

- Diagram [p.238]

FEATURES

COOLING TRIO

Our RIF1801 & RIL1800 in-column refrigeration models have been designed to complement our WC1801 wine cabinet, so you can create a luxurious cooling trio.

DOOR-ON-DOOR INSTALLATION

Refrigeration with a flawless finish. On models featuring door-on-door installation, hinges attach directly to your furniture door, keeping everything discreet and your kitchen looking seamless.

TWIST ICE CUBE MAKER

The twist ice cube maker is a convenient way to make ice, with the added benefits of easy removal for cleaning for those times when you need the extra space.

FROST-FREE

No more laborious defrosting with a scraper. Our frost-free system works by heating up an element for a short time, which melts the ice and prevents build-up. Keeping a freezer ice-free means food stays fresher for longer.

50/50 FRIDGE FREEZER – FROST-FREE



PRODUCT CODE

Ri5520

DIMENSIONS

h:1770mm

PERFORMANCE

e Energy class E
Noise class C
Energy consumption
232kWh/yr
Max. noise 41dB
3.9kg/24hr freezing
capacity

FINISH AVAILABLE

White

GENERAL FEATURES

- Reversible door
- Door on door installation
- Touch controls
- High temperature warning
- Open door audible alarm
- Eco mode
- Holiday mode
- Drink Cooling Mode

FRIDGE FEATURES

- Auto defrost
- Top LED strip light
- Super Cool
- Caple Cool air-flow system
- Caple Fresh

FREEZER FEATURES

- 4 star
- Frost-free
- Super freeze
- Ice cube tray

DESIGN

- Deluxe steel trimmed interior
- Transparent plastic drawers and compartments

FRIDGE STORAGE

- 3 Removable glass shelves
- 1 Easy adjustable door balcony
- 2 Standard door balconies
- 1 Egg tray
- 1 Humidity controlled drawer
- 1 Cover shelf

FREEZER STORAGE

- 3 Freezer drawers
- 1 Sliding tray
- 3 Removable glass shelves

CAPACITY

- 145 Litre fridge net capacity
- 85 Litre freezer net capacity

INSTALLATION

- Diagram [p.238]

FEATURES

DOOR-ON-DOOR INSTALLATION

Refrigeration with a flawless finish. On models featuring door-on-door installation, hinges attach directly to your furniture door, keeping everything discreet and your kitchen looking seamless.

FROST-FREE

No more laborious defrosting with a scraper. Our frost-free system works by heating up an element for a short time, which melts the ice and prevents build-up. Keeping a freezer ice-free means food stays fresher for longer.



Integrated Refrigeration.

FROST-FREE

No more laborious defrosting with a scraper. Our frost-free system works by heating up an element for a short time, which melts the ice and prevents build-up. Keeping a freezer ice-free means food stays fresher for longer. Freezing food is also much quicker, preserving as many nutrients as possible and freeing up much needed storage space.

FULLY ADJUSTABLE SHELF

Key features in RiL1796, Ri7308 & Ri5508 fridge include a fully adjustable shelf in the door for true flexibility in your cooling appliance.

MODERN LIVING

The RiL1796 fridge and RiF1797 freezer have been designed with modern living in mind. The matching, in-column fridge and freezer are hidden behind your cabinet doors for an ultra neat finish in a contemporary or classic kitchen.

ENHANCED LIGHTING

LED strip lighting across the top and down each side of the fridge for a stylish, practical finish.

GLASS SHELVES

Some of which have a deluxe steel trims to catch any spills.

IN-COLUMN LARDER FRIDGE



PRODUCT CODE

RiL1796

DIMENSIONS

h:1770mm

PERFORMANCE

Energy class E
Noise class C
Energy consumption
112kWh/yr
Max. noise 39dB [A]

FINISH AVAILABLE

White

FEATURES

- Matches RiF1797 freezer
- Reversible door
- Sliding door installation
- Electronic controls
- Auto defrost
- Top and side LED strip lights
- Super Cool
- Caple Cool air-flow system
- Caple Fresh

IN-COLUMN FREEZER



PRODUCT CODE

RiF1797

DIMENSIONS

h:1770mm

PERFORMANCE

Energy class E
Noise class C
Annual energy consumption
231kWh/yr
Max. noise 40dB [A]
11.5kg / 24hr freezing capacity

FINISH AVAILABLE

White

FEATURES

- Matches RiL1796 fridge
- Reversible door
- Sliding door installation
- Electronic controls
- 4 star
- Frost free
- Top LED strip light
- 1 Twist ice cube maker

DESIGN

- Deluxe steel trimmed interior
- Transparent plastic drawers and compartments

STORAGE

- 4 Removable glass shelves
- 1 Easy adjustable door balcony
- 4 Standard door balconies
- 1 Egg tray
- Wine rack
- 1 Humidity controlled drawer
- 2 Crisper drawers
- 1 Crisper cover shelf

CAPACITY

- 294 Litre total net capacity
- 303 Litre total gross capacity

INSTALLATION

- Diagram [p.238]

DESIGN

- Deluxe steel trimmed interior
- Transparent plastic drawers

STORAGE

- 6 Drawers
- 2 flip down door compartments

CAPACITY

- 197 Litre total net capacity

INSTALLATION

- Diagram [p.238]

FEATURES



TWIST ICE CUBE MAKER

The twist ice cube maker is a convenient way to make ice, with the added benefits of easy removal for cleaning for those times when you need the extra space.

70/30 FRIDGE FREEZER – FROST-FREE



PRODUCT CODE

Ri7308

DIMENSIONS

h:1770mm

PERFORMANCE

e Energy class E
Noise level C
Energy consumption
218kWh/yr
Max. noise level 38dB[A]
3.3kg/24hrs freezing
capacity

FINISH AVAILABLE

White

GENERAL FEATURES

- Reversible door
- Sliding door installation
- Electronic controls

FRIDGE FEATURES

- Auto defrost
- Top and side LED strip lights
- Super Cool
- Caple Cool air-flow system
- Caple Fresh

FREEZER FEATURES

- 4 star
- Frost-free
- Super freeze
- 1 Ice cube tray

DESIGN

- Deluxe steel trimmed interior
- Transparent plastic drawers and compartments

FRIDGE STORAGE

- 3 Removable glass shelves
- 1 Easy adjustable door balcony
- 3 Standard door balconies
- 1 Egg tray
- 1 Humidity controlled drawer
- 1 Crisper drawer
- 1 Crisper cover shelf

FREEZER STORAGE

- 2 Freezer drawers
- 1 Flip down door compartment
- 2 removable glass shelves

CAPACITY

- 180 Litre fridge net capacity
- 63 Litre freezer net capacity

INSTALLATION

- Diagram [p.238]

70/30 FRIDGE FREEZER



PRODUCT CODE

Ri7303

DIMENSIONS

h:1770mm

PERFORMANCE

e Energy class E
Noise level C
Energy consumption
217kWh/yr
Max. noise level 38dB[A]
3.3kg/24hrs freezing
capacity

FINISH AVAILABLE

White

GENERAL FEATURES

- Reversible door
- Sliding door installation
- Mechanical controls

FRIDGE FEATURES

- Auto defrost
- Top LED strip light

FREEZER FEATURES

- 4 star
- Manual defrost [low frost]
- Super freeze
- 1 Ice cube tray
- 1 Plastic ice scraper
- 1 Sliding tray

DESIGN

- Transparent plastic drawers and compartments

FRIDGE STORAGE

- 3 Removable glass shelves
- 4 Door balconies
- 1 Humidity controlled drawer
- 1 Egg tray
- 1 Crisper drawer
- 1 Crisper cover shelf

FREEZER STORAGE

- 2 Freezer drawers
- 1 Sliding tray

CAPACITY

- 181 Litre fridge net capacity
- 70 Litre freezer net capacity

INSTALLATION

- Diagram [p.238]

50/50 FRIDGE FREEZER – FROST-FREE



PRODUCT CODE

Ri5508

DIMENSIONS

h:1770mm

PERFORMANCE

e Energy class E
Noise class C
Energy consumption
232kWh/yr
Max. noise level 41dB[A]
3.9kg/24hrs freezing
capacity

FINISH AVAILABLE

White

GENERAL FEATURES

- Reversible door
- Sliding door installation
- Electronic controls

FRIDGE FEATURES

- Auto defrost
- Top LED strip light
- Super Cool
- Caple Cool air-flow system
- Caple Fresh

FREEZER FEATURES

- 4 star
- Frost-free
- Super freeze
- Ice cube tray

DESIGN

- Deluxe steel trimmed interior
- Transparent plastic drawers and compartments

FRIDGE STORAGE

- 3 Removable glass shelves
- 1 Easy adjustable door balcony
- 2 Standard door balconies
- 1 Egg tray
- 1 Humidity controlled drawer
- 1 Crisper drawer
- 1 Crisper cover shelf

FREEZER STORAGE

- 3 Freezer drawers
- 1 Sliding tray
- 3 Glass support shelves for freezer drawers

CAPACITY

- 145 Litre fridge net capacity
- 85 Litre freezer net capacity

INSTALLATION

- Diagram [p.239]

50/50 FRIDGE FREEZER



PRODUCT CODE

Ri5501

DIMENSIONS

h:1770mm

PERFORMANCE

e Energy class F
Noise class C
Energy consumption
279kWh/yr
Max. noise level 38dB[A]
5.5kg/24hrs freezing
capacity

FINISH AVAILABLE

White

GENERAL FEATURES

- Reversible door
- Sliding door installation
- Mechanical controls

FRIDGE FEATURES

- Auto defrost
- Top LED strip light

FREEZER FEATURES

- 4 star
- Manual defrost
- Super freeze
- Ice cube tray
- 1 Plastic ice scraper

DESIGN

- Transparent plastic drawers and compartments

FRIDGE STORAGE

- 3 Removable glass shelves
- 1 Egg tray
- 1 Crisper drawer
- 3 door balconies
- 1 Humidity controlled drawer
- 1 Crisper cover shelf

FREEZER STORAGE

- 3 Freezer drawers
- 1 Flip down door compartment

CAPACITY

- 146 Litre fridge net capacity
- 94 Litre freezer net capacity

INSTALLATION

- Diagram [p.239]

IN-COLUMN LARDER FRIDGE



PRODUCT CODE

RiL126

DIMENSIONS

h:1220mm

PERFORMANCE

e Energy class E
Noise level B
Energy consumption
100kWh/yr
Max. noise level 35dB[A]

FINISH AVAILABLE

White

FEATURES

- Matches RiF126 freezer
- Reversible door
- Sliding door installation
- Mechanically controlled
- Auto defrost
- LED light

DESIGN

- Deluxe steel trimmed interior
- Transparent plastic drawer and compartments

STORAGE

- 4 Removable glass shelves
- 3 Standard door balconies
- 1 Egg tray
- 1 Crisper drawer
- 1 Crisper cover shelf

CAPACITY

- 197 Litre total net capacity

INSTALLATION

- Diagram [p.239]

IN-COLUMN FREEZER



PRODUCT CODE

RiF126

DIMENSIONS

h:1220mm

PERFORMANCE

e Energy class E
Noise level C
Energy consumption
186kWh/yr
Max. noise level 39dB[A]
6kg/24hrs freezing
capacity

FINISH AVAILABLE

White

FEATURES

- Matches RiL126 larder fridge
- Reversible door
- Sliding door installation
- Electronic controls
- 4 Star
- Manual defrost
- 1 Ice cube tray

DESIGN

- Deluxe steel trimmed interior
- Transparent blue plastic drawers

STORAGE

- 5 Drawers

CAPACITY

- 127 Litre total net capacity

INSTALLATION

- Diagram [p.239]

IN-COLUMN LARDER FRIDGE



PRODUCT CODE

RiL893

DIMENSIONS

h:880mm

PERFORMANCE

e Energy class E
Noise level B
Energy consumption
92kWh/yr
Max. noise level
35dB[A]

FINISH AVAILABLE

White

FEATURES

- Matches RiF893 freezer
- Reversible door
- Sliding door installation
- Electronic controls
- LED Light
- Open door audible alarm

DESIGN

- Transparent plastic drawer and compartments
- Deluxe steel trimmed interior

STORAGE

- 3 Removable glass shelves
- 3 Standard door balconies
- 1 Egg tray
- 1 Crisper drawer
- 2 half size crisper drawers

CAPACITY

- 135 Litre total net capacity

INSTALLATION

- Diagram [p.239]

IN-COLUMN FREEZER



PRODUCT CODE

RiF893

DIMENSIONS

h:880mm

PERFORMANCE

e Energy class E
Noise level C
Energy consumption
170kWh/yr
Max. noise level 38dB[A]
3kg/24hrs freezing
capacity

FINISH AVAILABLE

White

FEATURES

- Matches RiL893 larder fridge
- Reversible door
- Sliding door installation
- Mechanically controlled
- 4 Star
- Manual defrost
- Ice cub tray

DESIGN

- Deluxe steel trimmed interior
- Transparent blue plastic drawers

STORAGE

- 4 Drawers

CAPACITY

- 77 Litre total net capacity

INSTALLATION

- Diagram [p.239]

LARDER FRIDGE WITH ICE BOX



PRODUCT CODE

RIR125

DIMENSIONS

 h:1221

PERFORMANCE

e Energy class E
 Noise level C
 Energy consumption
 148kWh/yr
 Freezing capacity
 2.6kg/24hr
 Max. noise level 39dB[A]

FINISH AVAILABLE

 White

GENERAL FEATURES

- Reversible door
- Sliding door installation
- Electronic controls
- LED Lights

FRIDGE FEATURES

- Auto defrost
- Matches RIF126 freezer
- Deluxe steel trim

FREEZER FEATURES

- 4 Star
- Manual defrost

FRIDGE STORAGE

- 3 Removable glass shelves
- 1 Egg tray
- 3 Door balconies
- 1 Crisper drawer
- 1 Crisper cover shelf

FREEZER STORAGE

- 1 Ice cube tray

CAPACITY

- 163 Litre fridge net capacity
- 16 Litre freezer net capacity

INSTALLATION

- Diagram [p.239]

BUILT-UNDER LARDER FRIDGE



PRODUCT CODE

RBL6

DIMENSIONS

 w:595mm

PERFORMANCE

e Energy class E
 Energy consumption
 93kWh/yr
 Max. noise level 39dB[A]

FINISH AVAILABLE

 White

FEATURES

- Matches RBF6 freezer
- Mechanically controlled
- Auto defrost
- Adjustable thermostat
- 100% CFC/HFC free
- Door on door installation
- Reversible door
- Interior LED light

DESIGN

- Deluxe silver trimmed door balconies
- Transparent glass shelves and plastic compartments

STORAGE

- 2 Adjustable glass shelves
- 1 Crisper cover shelf
- 1 Crisper drawer
- 2 Door balconies
- 1 Egg tray

CAPACITY

- 134 Litre total net capacity

INSTALLATION

- Diagram [p.239]

BUILT-UNDER FREEZER



PRODUCT CODE

RBF6

DIMENSIONS

 w:595mm

PERFORMANCE

e Energy class E
 Energy consumption
 176kWh/yr
 Max. noise level 39dB[A]
 5kg/24hrs freezing capacity

FINISH AVAILABLE

 White

FEATURES

- Matches RBL6 larder fridge
- Mechanically controlled
- 4 Star
- Manual defrost
- Adjustable thermostat
- 100% CFC/HFC free
- Reversible door
- Fixed door installation

DESIGN

- Transparent plastic drawers

STORAGE

- 3 Drawers
- 1 Ice cube tray

CAPACITY

- 96 Litre total net capacity

INSTALLATION

- Diagram [p.239]

BUILT-UNDER LARDER FRIDGE WITH ICE BOX



PRODUCT CODE

RBR8

DIMENSIONS

 w:595mm

PERFORMANCE

e Energy class E
 Energy consumption
 149kWh/yr
 Max. noise level 39dB[A]
 2.6kg/24hrs freezing capacity

FINISH AVAILABLE

 White

FEATURES

- Matches RBF6 freezer
- Mechanically controlled
- Adjustable thermostat
- 100% CFC/HFC free
- Fixed door installation
- Reversible door
- Ice box open/closed indicator

Fridge

- Auto defrost
- Interior LED light

Ice Box

- 4 Star
- Super Freeze
- Manual defrost

DESIGN

- Deluxe silver trimmed door balconies
- Transparent glass shelves and plastic compartments

STORAGE

- 1 Glass shelf
- 1 Glass crisper cover shelf
- 1 Salad crisper
- 2 Plastic door storage compartments
- 1 Egg tray
- 1 Ice cube tray

CAPACITY

- 98 Litre fridge net capacity
- 17 Litre ice box net capacity

INSTALLATION

- Diagram [p.239]

Wine Cabinets.

Caple's wine cabinets create the optimum storage conditions for your wine; the correct temperature, humidity and air circulation. They even use low vibration technology to minimise disturbance.

And of course, they look great.



Care For Your Collection.



TO STORE

All wine should be stored at 12-14°C whether red or white. Our cabinets simulate cellar conditions - dark, still, humid and a constant temperature.

TO SERVE

For rosés and whites it's 8-14°C, for sparkling wines it's 6-10°C. Full reds need 16-18°C, whereas lighter ones are best at 13-16°C. For some wine cabinets this temperature variation is a problem. However, Caple cabinets can offer multiple zones that keep all your wines at the perfect temperature for storing or better still, serving.

COMPRESSOR COOLING

When choosing a wine cabinet it's important to consider the type of cooling system it uses. Many conventional cabinets use thermo electric technology, which is only capable of cooling to 15°C below the room's ambient temperature. So on a warm day of 25°C the contents will only cool to a minimum of 10°C, leaving your wine exposed to potentially damaging temperatures.

Caple's wine cabinets use a compressor cooling system, which maintains precisely the right temperature, regardless of the ambient room temperature.

THE IMPORTANCE OF LIGHTING + STACKING

Ultraviolet light causes lightstrike, which makes wine age prematurely. So it's important to avoid exposing bottles to sunlight or fluorescent light. Our white LEDs not only look great, they are also UV-free with no heat output either.

Bottles should usually be stored on their side so the wine stays in contact with the cork. This keeps the cork moist and ensures a good air seal for the bottle, which prevents oxidation and immediate ageing.

Wine benefits best from side storage if the level of the wine reaches at least the upper shoulder of the bottle when upright. Caple's wine cabinets provide sufficient shelves to allow for bottles to be stored either on a single level for easy reach, or stacked for longer storage.

FINER WINE

Vibration and humidity during storage will influence how your wine will taste when it's finally poured. That's why Caple's wine cabinets come with anti-vibration gaskets and low vibration compressors to prevent disturbance to the wine's sediment balance. Our cabinets also create an ideal atmosphere of above 65% humidity, to preserve cork quality and prevent mould and odours. You can be confident your wine is in good hands.



Sense Premium Wine Cabinets.

TELESCOPIC SHELVES

The beech and Stainless Steel fronted telescopic wire shelves are gentle on the bottles, reducing any accidental scratches on the label and allowing you to easily view your collection. Perfect for Burgundy, Bordeaux and Champagne bottles.

AIR PURIFYING TECHNOLOGY

Charcoal filters eliminate odours and impurities in the air, preventing them from penetrating the cork, to ensure your collection is at its best when it comes to serving.

PREMIUM FUNCTIONALITY

Four light settings and four functions means you can find the right storage environment to suit your wine.

FULLY INTEGRATED

The Wi6161 & WC1801 integrated wine cabinets are perfect for creating a seamless aesthetic. Simply make a frame for the cabinet to match your kitchen furniture to create a seamlessly discreet and truly unique, luxurious style.

sp Look out for products marked with Sense Premium flags to easily identify the range.



NORMAL MODE

The wine cabinet will operate with the temperatures you select.



DOOR OPENING LIGHT

Internal light will switch on when the door is opened, and off when the door is closed.



ON/OFF

Internal light is continuously on. Three minutes after closing the door the light will dim for a more subtle look.



INTELLIGENT MODE

The fan speed adjusts according to the ambient temperature so the cabinet doesn't have to work as hard and also saves energy.



BRIGHTNESS

Once a light function is selected you can adjust the brightness of the internal lighting.



ECO MODE

Lighting and control panel turns off and the compressor is delayed. Perfect for saving energy.



TIMER

This function keeps the lights on for 10 minutes once the door is closed and then switches off.



DEMO MODE

Primarily for Retail use. In this mode the compressor and heater are disabled and the fan input is reduced.



SENSE PREMIUM FULLY INTEGRATED IN-COLUMN TRIPLE ZONE WINE CABINET

PRODUCT CODE

sp WC1801

DIMENSIONS

h:1744mm

PERFORMANCE

e Energy class G
Noise class C
Energy consumption
158kWh/yr
Ambient temperature
16°C - 32°C
Temperature range
upper zone 5°C - 18°C
middle zone 5°C - 10°C
lower zone 10°C - 18°C
Humidity range >65%RH
Quiet operation 38dB[A]

FUNCTIONS

4 Light Functions

- On/Off
- Door opening light
- Timer
- Brightness

4 Programme Settings

- Normal
- Eco
- Intelligent
- Demo

GENERAL FEATURES

- Bespoke furniture door to match your kitchen cabinets required
- Full furniture door with no window can be fitted
- Soft close door
- Shelves can accommodate 750ml Bordeaux, Burgundy and Champagne bottles
- No-frost compressor cooling technology maintains a consistent temperature
- Touch controls and white LED display

- Converts into a can chiller using optional glass shelving
- Charcoal filters [x3]
- UV/heat-free white LED lighting [switchable]
- Vibration free
- Telescopic beech fronted wire shelves with steel trim
- Fan circulated cool air for even temperature distribution

- Reversible door
- 2 heaters raise internal temperature when external temperature drops
- High temperature and open door alarm
- Upper zone has 2 telescopic shelves and 1 display shelf
- Middle zone has 3 telescopic shelves and 1 display shelf
- Lower zone has 3 telescopic shelves and 1 base shelf
- 100% CFC/HFC free

- Toughened UV protected glass door
- Black cabinet interior and Stainless Steel back panel
- Wine labels and holders included

- Air ventilation through plinth grille
- Supplied with Stainless Steel universal plinth grille w:525mm

CAPACITY

- Stores max.70 Bordeaux style wine bottles 750ml
- Bottle Stacking diagrams available at caple.co.uk

OPTIONAL EXTRAS

- 6 Wine labels and holders [WINELABEL]
- Metallic handles available [see p.190 for full range]
- Metallic grilles available [see p.191 for full range]
- 1 Glass shelf [GSHELF4]
- Replacement carbon filter [WC1CF]
- Visit caple.co.uk for full range

INSTALLATION

- Diagram [p.241]



SENSE PREMIUM FULLY INTEGRATED UNDERCOUNTER DUAL ZONE WINE CABINET

PRODUCT CODE

sp Wi6161

DIMENSIONS

w:595mm

PERFORMANCE

e Energy class F
Noise class C
Energy consumption
103kWh/yr
Ambient temperature
16°C - 32°C
Temperature range
upper zone 5°C-10°C,
lower zone 10°C - 18°C
Humidity range >65%RH
Quiet operation 38dB[A]

FUNCTIONS

4 Light Functions

- On/Off
- Door opening Light
- Timer
- Brightness

4 Programme Settings

- Normal
- Eco
- Intelligent
- Demo

GENERAL FEATURES

- Bespoke furniture door to match your kitchen cabinets required
- Soft close door
- Full furniture door with no window can be fitted
- Shelves can accommodate 750ml Bordeaux, Burgundy and Champagne bottles
- No frost compressor cooling technology maintains a consistent temperature
- Dual stacked temperature zones, independently controlled [upper zone for serving, lower zone for storage]

- Touch controls and white LED display
- Converts into a can chiller using optional glass shelving
- Charcoal filter
- UV/heat-free white LED lighting [switchable]
- Vibration free
- Adjustable height to fit 100-150mm plinth

- Telescopic beech fronted wire shelves with steel trim
- Fan circulated cool air for even temperature distribution
- Reversible door
- Heater raises internal temperature when external temperature drops
- High temperature and open door alarm
- Upper zone has 2 telescopic shelves

- Lower zone has 2 telescopic shelves and 1 base shelf
- 100% CFC/HFC free
- Toughened UV protected glass door
- Black cabinet interior and exterior
- Recessed for fitting furniture plinth

- Air ventilation through plinth grille
- Supplied with Stainless Steel universal plinth grille w:525mm

CAPACITY

- Stores max. 35 Bordeaux style wine bottles 750ml
- Bottle stacking diagrams available at caple.co.uk

OPTIONAL EXTRAS

- 6 Wine labels [WINELABEL]
- Metallic handles available [see p.190 for full range]
- Metallic grilles available [see p.191 for full range]
- 1 Glass shelf [GSHELF3]
- Filler panel [FP600SS]
- Replacement carbon filter [WC1CF]
- Visit caple.co.uk for full range

INSTALLATION

- Diagram [p.239]

SENSE PREMIUM UNDERCOUNTER DUAL ZONE WINE CABINETS



WI6155BG



WI6150

PRODUCT CODE

- sp** Black Glass Wi6155BG
- sp** Stainless Steel Wi6150

DIMENSIONS

- ↔ w:595mm

PERFORMANCE

- e** Energy class F
- Noise class C
- Energy consumption 103kWh/yr
- Ambient temperature 16°C - 32°C
- Temperature range upper zone 5°C-10°C, lower zone 10°C - 18°C
- Humidity range >65%RH
- Quiet operation 38dB[A]

FINISH AVAILABLE

- Black Glass
- Stainless Steel

FUNCTIONS

- 4** Light Functions
 - On/Off
 - Door opening Light
 - Timer
 - Brightness

4 Programme Settings

- Normal
- Eco
- Intelligent
- Demo

GENERAL FEATURES

- Shelves can accommodate 750ml Bordeaux, Burgundy and Champagne bottles
- No frost compressor cooling technology maintains a consistent temperature
- Dual stacked temperature zones, independently controlled [upper zone for serving, lower zone for storage]
- Touch controls and white LED display
- Converts into a can chiller using optional glass shelving
- Charcoal filter

- UV/heat-free white LED lighting [switchable]
- Vibration free
- Adjustable height to fit 100-150mm plinth
- Telescopic beech fronted wire shelves with steel trim
- Fan circulated cool air for even temperature distribution
- Reversible door
- Heater raises internal temperature when external temperature drops
- High temperature and open door alarm
- Upper zone has 2 telescopic shelves
- Lower zone has 2 telescopic shelves and 1 base shelf
- 100% CFC/HFC free
- Toughened UV protected glass door
- Recessed for fitting furniture plinth
- Air ventilation through plinth grille

- Reversible door
- Heater raises internal temperature when external temperature drops
- High temperature and open door alarm
- Upper zone has 2 telescopic shelves
- Lower zone has 2 telescopic shelves and 1 base shelf
- 100% CFC/HFC free
- Toughened UV protected glass door
- Recessed for fitting furniture plinth
- Air ventilation through plinth grille

WI6155BG UNIQUE FEATURES

- One piece Black glass door
- Black square handle
- Supplied with Black Steel universal plinth grille w:525mm

WI6150 UNIQUE FEATURES

- One piece Stainless Steel door
- Stainless Steel handle
- Supplied with Stainless Steel universal plinth grille w:525mm and full width grille

CAPACITY

- Stores max. 44 Bordeaux style wine bottles 750ml
- Bottle stacking diagrams available at caple.co.uk

OPTIONAL EXTRAS

- 6 Wine labels [WINELABEL]
- Replacement carbon filter [WC1CF]
- 1 Glass shelf [GSHELF2]
- Filler panel [FP600BK] Wi6155BG only
- Filler panel [FP600SS] Wi6150 only
- Metallic handles available [see p.190 for full range]
- Metallic grilles available [see p.191 for full range]
- Visit caple.co.uk for full range

INSTALLATION

- Diagram [p.240]

SENSE PREMIUM UNDERCOUNTER SINGLE ZONE WINE CABINETS



WI3155BG



WI3150

PRODUCT CODE

- sp** Wi3155BG
- sp** Wi3150

DIMENSIONS

- ↔ w:295mm

PERFORMANCE

- e** Energy class F
- Noise level C
- Energy consumption 98kWh/yr
- Ambient temperature 16°C - 32°C
- Temperature range 5°C - 18°C
- Humidity range >65%RH
- Quiet operation 39dB[A]

FINISH AVAILABLE

- Black Glass
- Stainless Steel

FUNCTIONS

- 4** Light Functions
 - On/Off
 - Door opening Light
 - Timer
 - Brightness

4 Programme Settings

- Normal
- Eco
- Intelligent
- Demo

GENERAL FEATURES

- Shelves can accommodate 750ml Bordeaux, Burgundy and Champagne bottles
- No-frost compressor cooling technology maintains a consistent temperature
- Single temperature zone, stores either red, white or sparkling wine
- Touch controls and white LED display
- Converts into a can chiller using optional glass shelving
- Charcoal filter
- UV/heat-free white LED lighting [switchable]

- Vibration free
- Adjustable height to fit 100 - 150mm plinth
- Fan circulated cool air for even temperature distribution
- Reversible door
- Heater raises internal temperature when external temperature drops
- High temperature and open door alarm
- Telescopic beech fronted wire shelves with steel trim
- 5 Telescopic shelves and 1 base shelf
- 100% CFC/HFC free
- Toughened UV protected glass door
- Recessed for fitting furniture plinth
- Air ventilation through plinth grille

- Reversible door
- Heater raises internal temperature when external temperature drops
- High temperature and open door alarm
- Telescopic beech fronted wire shelves with steel trim
- 5 Telescopic shelves and 1 base shelf
- 100% CFC/HFC free
- Toughened UV protected glass door
- Recessed for fitting furniture plinth
- Air ventilation through plinth grille

WI3155BG UNIQUE FEATURES

- One piece Black glass door
- Black square handle
- Supplied with Black Steel universal plinth grille w:230mm

WI3150 UNIQUE FEATURES

- One piece Stainless Steel door
- Stainless Steel handle
- Supplied with Stainless Steel universal plinth grille w:230mm and full width grille

CAPACITY

- Stores max. 20 Bordeaux style wine bottles 750ml
- Bottle stacking diagrams available at caple.co.uk

OPTIONAL EXTRAS

- 6 Wine labels and holders [WINELABEL]
- 1 Glass shelf [GSHELF1]
- Replacement carbon filter [WC1CF]
- Filler panel [FP300BK] Wi3155BG only
- Filler panel [FP300SS] Wi3150 only
- Metallic handles available [see p.190 for full range]
- Metallic grilles available [see p.191 for full range]
- Visit caple.co.uk for full range

INSTALLATION

- Diagram [p.240]



Undercounter Wine Cabinets.

UNDERCOUNTER DUAL ZONE WINE CABINETS



Wi6136BG



Wi6135BS



Wi6135GM



Wi6135

PRODUCT CODE

Black Glass	Wi6136BG
Black Steel	Wi6135BS
Gunmetal	Wi6135GM
Stainless Steel	Wi6135

DIMENSIONS

← w:595mm

PERFORMANCE

e Energy class G
 Noise level C
 Energy consumption 145kWh/yr
 Ambient temperature 16°C - 32°C
 Temperature range upper zone 5°C - 10°C, lower zone 10°C - 18°C
 Humidity range >65%RH
 Quiet operation 39dB[A]

FINISH AVAILABLE

- Black Glass
- Black Steel
- Gunmetal
- Stainless Steel

GENERAL FEATURES

- Shelves can accommodate 750ml Bordeaux, Burgundy and Champagne bottles
- No-frost compressor cooling technology maintains a consistent temperature
- Dual stacked temperature zones, independently controlled [upper zone serving, lower zone storage]
- Touch control and white LED display
- UV/heat-free white LED lighting [switchable]
- Vibration free
- Adjustable height to fit 100 - 150mm plinth
- Beech shelves
- Fan circulated cool air for even temperature distribution
- Reversible door
- Heater raises internal temperature when external temperature drops

- Upper zone has 2 sliding shelves
- Lower zone has 3 sliding shelves and 1 base shelf
- 100% CFC/HFC free
- 2 Humidity control water tanks
- Toughened UV protected glass door
- Recessed for fitting furniture plinth
- Air ventilation through plinth grille

Wi6136BG UNIQUE FEATURES

- One piece Black Glass door
- Black square handle
- Supplied with Black Steel universal plinth grille w:525mm

Wi6135BS UNIQUE FEATURES

- One piece Stainless Steel door with Black Steel finish
- Black square handle
- Supplied with Black Steel universal plinth grille w:525mm

Wi6135GM UNIQUE FEATURES

- One piece Stainless Steel door with Gunmetal finish
- Black square handle
- Supplied with both Gunmetal universal plinth grille w:525mm and full width grille

Wi6135 UNIQUE FEATURES

- One piece Stainless Steel door
- Stainless Steel square handle
- Supplied with both universal plinth grille w:525mm and full width grille

CAPACITY

- Stores max. 46 Bordeaux style wine bottles 750ml [16 upper zone and 30 lower zone]
- Bottle stacking diagrams available at caple.co.uk

OPTIONAL EXTRAS

- 6 Wine labels [WINELABEL]
- Filler panel [FP600BK] for Wi6136BG and Wi6135BS only
- Filler panel [FP600GM] for Wi6135GM only
- Filler panel [FP600SS]
- Metallic handles available [see p.190 for full range]
- Metallic grilles available [see p.191 for full range]
- Visit caple.co.uk for full range

INSTALLATION

- Diagram [p.240]

UNDERCOUNTER DUAL ZONE WINE CABINETS



Wi6235BG

PRODUCT CODE

Black Glass	Wi6235BG
Stainless Steel	Wi6234

DIMENSIONS

↔ w:595mm

PERFORMANCE

- e** Energy class G
- Noise class C
- Energy consumption 142kWh/yr
- Ambient temperature 10°C - 32°C
- Temperature range 5°C - 18°C [both zones]
- Humidity range >65%RH
- Quiet operation 39dB[A]

FINISH AVAILABLE

- Black Glass
- Stainless Steel

GENERAL FEATURES

- Shelves can accommodate 750ml Bordeaux, Burgundy and Champagne bottles
- No-frost compressor cooling technology maintains a consistent temperature
- Dual side-by-side temperature zones, independently controlled [both zones suitable for either serving or storage]
- Touch controls and white LED display
- Converts into a can chiller using optional glass shelving
- UV/heat-free white LED lighting [switchable]
- Vibration free
- Adjustable height to fit 100-150mm plinth
- Beech shelves
- Fan circulated cool air for even temperature distribution
- 5 Sliding shelves and 1 base shelf per zone

- 100% CFC/HFC free
- Toughened UV protected glass door
- 2 Humidity control water tanks
- Recessed for fitting furniture plinth
- Air ventilation through plinth grille

WI6235BG UNIQUE FEATURES

- Black Glass doors
- Black square handles
- Supplied with Black Steel universal plinth grille w:525mm

WI6234 UNIQUE FEATURES

- Stainless Steel doors
- Stainless Steel square handles
- Supplied with both Stainless Steel universal plinth grille w:525mm and full width grille

CAPACITY

- Stores max. 38 Bordeaux style wine bottles 750ml [19 bottles per zone]
- Bottle stacking diagrams available at caple.co.uk

OPTIONAL EXTRAS

- 6 Wine labels [WINELABEL]
- 3 Frosted glass shelves with Black plastic trim [GSHELFPACK/300]
- Full height Black Steel grille with fixing brackets [GRILL/CLASS6/BS] for Wi6235BG
- Metallic handles available [see p.190 for full range]
- Metallic grilles available [see p.191 for full range]
- Visit caple.co.uk for full range

INSTALLATION

- Diagram [p.240]



Wi6234

UNDERCOUNTER SINGLE ZONE WINE CABINETS



Wi6143BG



Wi6142

PRODUCT CODE

Black Glass	Wi6143BG
Stainless Steel	Wi6142

DIMENSIONS

↔ w:595mm

PERFORMANCE

- e** Energy class G
- Noise level C
- Energy consumption 130kWh/yr
- Ambient temperature 16°C - 32°C
- Temperature range 5°C - 18°C
- Humidity range >65%RH
- Quiet operation 39dB[A]

FINISH AVAILABLE

- Black Glass
- Stainless Steel

GENERAL FEATURES

- Shelves can accommodate 750ml Bordeaux, Burgundy and Champagne bottles
- No-frost compressor cooling technology maintains a consistent temperature
- Single temperature zone stores red, white or sparkling wine
- Touch controls and white LED display
- Converts into a can chiller using optional glass shelving
- UV/heat-free white LED lighting [switchable]
- Vibration free
- Adjustable height to fit 100-150mm plinth
- Beech shelves
- Fan circulated cool air for even temperature distribution
- Reversible door
- 5 Sliding shelves and 1 base shelf
- 100% CFC/HFC free
- Toughened UV protected glass door
- Humidity control water tank
- Recessed for fitting furniture plinth
- Air ventilation through plinth grille

WI6143BG UNIQUE FEATURES

- One piece Black Glass door
- Black square handle
- Supplied with Black universal plinth grille w:525mm

WI6142 UNIQUE FEATURES

- One piece Stainless Steel door
- Stainless Steel square handle
- Supplied with both Stainless Steel universal plinth grille w:525mm and full width grille

CAPACITY

- Stores max. 52 Bordeaux style wine bottles 750ml [8 bottles per sliding shelf, 6 bottles on base shelf, 14 on top shelf]
- Bottle stacking diagrams available at caple.co.uk

OPTIONAL EXTRAS

- 6 Wine labels [WINELABEL]
- 3 Frosted glass shelves with Black plastic trim [GSHELFPACK/600]
- Full height Black Steel grille with fixing brackets [GRILL/CLASS6/BS] for Wi6143BG
- Filler panel [FP600BK] for Wi6143BG only
- Filler panel [FP600SS] for Wi6142 only
- Metallic handles available [see p.190 for full range]
- Metallic grilles available [see p.191 for full range]
- Visit caple.co.uk for full range

INSTALLATION

- Diagram [p.240]

UNDERCOUNTER SINGLE ZONE WINE CABINETS



Wi3126BG



Wi3125BS



Wi3125GM



Wi3125

PRODUCT CODE

Black Glass	Wi3126BG
Black Steel	Wi3125BS
Gunmetal	Wi3125GM
Stainless Steel	Wi3125

DIMENSIONS

↔ w:295mm

PERFORMANCE

e Energy class F
 Noise level C
 Energy consumption 98kWh/yr
 Ambient temperature 16°C - 32°C
 Temperature range 5°C - 18°C
 Humidity range >65%RH
 Quiet operation 39dB[A]

FINISH AVAILABLE

- Black Glass
- Black Steel
- Gunmetal
- Stainless Steel

GENERAL FEATURES

- Shelves can accommodate 750ml Bordeaux, Burgundy and Champagne bottles
- No-frost compressor cooling technology maintains a consistent temperature
- Single temperature zone stores red, white or sparkling wine
- Touch controls and white LED display
- Converts into a can chiller using optional glass shelving
- UV/heat-free white LED lighting [switchable]
- Vibration free
- Adjustable height to fit 100-150mm plinth
- Beech shelves
- Fan circulated cool air for even temperature distribution
- Reversible door
- 5 Sliding shelves and 1 base shelf
- 100% CFC/HFC free

- Toughened UV protected glass door
- Humidity control water tank
- Recessed for fitting furniture plinth

Wi3126BG + Wi3125BS UNIQUE FEATURES

- One piece Black Glass door
- Black square handle
- Supplied with Black Steel universal plinth grille w:230mm

Wi3125GM UNIQUE FEATURES

- One piece Stainless Steel door with Gunmetal finish
- Black square handle
- Supplied with both Gunmetal universal plinth grille w:230mm and full width grille

Wi3125 UNIQUE FEATURES

- One piece Stainless Steel door
- Stainless Steel square handle
- Supplied with both universal plinth grille w:230mm and full width grille

CAPACITY

- Stores max.19 Bordeaux style wine bottles 750ml
- Bottle stacking diagrams available at caple.co.uk

OPTIONAL EXTRAS

- 6 Wine labels [WINELABEL]
- 3 Frosted glass shelves with Black plastic trim [GSHELFPACK/300]
- Filler panel [FP300BK] for Wi3126BG and Wi3125BS only
- Filler panel [FP300GM] for Wi3125GM only
- Filler panel [FP300SS]
- Metallic handles available [see p.190 for full range]
- Metallic grilles available [see p.191 for full range]
- Visit caple.co.uk for full range

INSTALLATION

- Diagram [p.240]

UNDERCOUNTER SINGLE ZONE WINE CABINETS



Wi158BG



Wi159

PRODUCT CODE

Black Glass	Wi158BG
Stainless Steel	Wi159

DIMENSIONS

↔ w:145mm

PERFORMANCE

e Energy class G
 Noise class C
 Energy consumption 133kWh/yr
 Ambient temperature 16°C - 32°C
 Temperature range 5°C - 18°C
 Humidity range >65%RH
 Quiet operation 39dB[A]

FINISH AVAILABLE

- Black Glass
- Stainless Steel

FEATURES

- No-frost compressor cooling technology maintains a consistent temperature
- Single temperature zone stores red, white or sparkling wine
- Touch controls and white LED display
- UV/heat-free white LED lighting [switchable]
- Vibration free
- Adjustable height to fit 100 - 150mm plinth
- Wooden bottle rack
- Stainless Steel square handle
- Fan circulated cool air for even temperature distribution
- Reversible door
- 6 Wooden rack slots and 1 base shelf
- 100% CFC/HFC free
- Toughened UV protected glass door
- Black cabinet interior and exterior
- Air ventilation through plinth grille

Wi158BG UNIQUE FEATURES

- One piece Black Glass door
- Supplied with Black Steel universal plinth grille w:144mm

Wi159 UNIQUE FEATURES

- One piece Stainless Steel door
- Supplied with both Stainless Steel universal plinth grille w:144mm and full width grille

CAPACITY

- Stores max. 8 Bordeaux style wine bottles 750ml
- Not suitable for champagne bottles
- Bottle stacking diagrams available at caple.co.uk

OPTIONAL EXTRAS

- Metallic handles available [see p.190 for full range]
- Metallic grilles available [see p.191 for full range]
- Full height Stainless Steel grille with fixing brackets [GRILL/CLASS150] for Wi158BG only
- Visit caple.co.uk for full range

INSTALLATION

- Diagram [p.240]

In-column Wine Cabinets.



Fully Integrated



SEAMLESSLY INTEGRATED

Simply make a frame for our WC6530 and WC6130 to match your kitchen furniture, to create a seamlessly discreet and truly unique, luxurious style, with all the premium functionality that you expect with a Caple wine cabinet.



EFFICIENT VENTILATION

Enjoy hassle-free installation with the self-ventilating feature of the WC6530 and WC6130 wine cooler, eliminating the need for a plinth grille as air is efficiently drawn beneath the appliance and expelled above the door back into the room.



LED LIGHTING

Illuminate your wine collection in style with the LED side strip lights, providing improved visibility and showcasing your beautiful assortment with elegance.

FULLY INTEGRATED IN-COLUMN WINE CABINETS



WC6530



WC6130

PRODUCT CODE

WC6530
WC6130

DIMENSIONS

h:886mm [WC6530]
h:600mm [WC6130]

PERFORMANCE

Energy class G
Noise level B
Energy consumption
143kWh/yr [WC6530]
131kWh/yr [WC6130]
Ambient temperature
16°C - 32°C
Temperature range
5°C - 20°C
Humidity range >65%RH
Quiet operation 36dB[A]
[WC6530]
Quiet operation 35dB[A]
[WC6130]

FUNCTIONS

4 Programme Settings
Sabbath Mode
Demo
Eco
Fan

FEATURES

- Adjustable sound controls
- Dimmable internal lights
- Adjustable display brightness
- Bespoke furniture door to match your kitchen cabinets required
- Soft close door
- Self ventilation
- Can be fitted with full furniture door without a window
- Shelves can accommodate 750ml Bordeaux, Burgundy and Champagne bottles
- Dual stacked temperature zones, independently controlled [upper zone to serve, lower zone storage]
- Touch control and white LED display
- Charcoal filter

- UV/heat-free white LED lighting [switchable]
- Vibration free
- Beech shelves
- Fan circulated cool air for even temperature distribution
- Reversible door
- High temperature and open door alarm
- Upper zone has 2 sliding shelves
- Moulded shelf supports
- 100% CFC/HFC free
- Toughened UV protected glass door
- Humidity control water tank
- Self ventilating [no need for plinth ventilation]

WC6530 UNIQUE FEATURES

- Lower zone features 2 sliding shelves & 1 display shelf

WC6130 UNIQUE FEATURES

- Installation either in-column or undercounter
- Lower zone has 1 sliding shelf and 1 display shelf

WC6530 CAPACITY

- Stores max. 45 Bordeaux style wine bottles 750ml

WC6130 CAPACITY

- Stores max. 23 Bordeaux style wine bottles 750ml
- Bottle stacking diagrams available at caple.co.uk

OPTIONAL EXTRA

- Replacement carbon filter [WC1CF]
 - Metallic handles available [see p.190 for full range]
- Visit caple.co.uk for full range

INSTALLATION

- Diagram [p.240]

IN-COLUMN TRIPLE ZONE WINE CABINETS



WC1796BG

PRODUCT CODE

Black Glass	WC1796BG
Stainless Steel	WC1792

DIMENSIONS

h:1788mm

PERFORMANCE

e Energy class G
Noise level C
Energy consumption 162kWh/yr
Ambient temperature 16°C - 32°C
Temperature range upper zone 5°C - 18°C
middle zone 5°C - 10°C
lower zone 10°C - 18°C
Humidity range >65%RH
Quiet operation 38dB[A]

FINISH AVAILABLE

	Black Glass
	Stainless Steel

FEATURES

- Shelves can accommodate 750ml Bordeaux, Burgundy and Champagne bottles
- No-frost compressor cooling technology maintains a consistent temperature
- Triple stacked temperature zones, independently controlled for storage or serving
- Touch control and white LED display
- UV/heat-free white LED lighting [switchable]
- Vibration free
- Telescopic beech shelves
- Fan circulated cool air for even temperature distribution
- Reversible door
- High temperature and open door alarm
- 2 Heaters raise internal temperature when external temperature drops
- Upper zone has 2 sliding shelves and 1 display shelf
- Middle zone has 3 sliding shelves and 1 display shelf
- Lower zone has 3 sliding shelves and 1 base shelf
- Double stacked shelves



WC1792

FEATURES

- 100% CFC/HFC free
- Toughened UV protected glass door
- 3 Humidity control water tanks
- Black cabinet interior and Stainless Steel back panel
- Air ventilation through plinth grille

WC1796BG UNIQUE FEATURES

- One piece Black Glass door
- Black square handle
- Supplied with Black Steel universal plinth grille w:525mm

WC1792 UNIQUE FEATURES

- One piece Stainless Steel door
- Square Stainless Steel handle
- Supplied with Stainless Steel universal plinth grille w:525mm

FEATURES

STAINLESS STEEL DOOR

*Matching Stainless Steel doors available suitable for our larder fridge and freezer for a more professional aesthetic.



CAPACITY

- Stores max. 89 Bordeaux style wine bottles 750ml [29 bottles on upper zone, 25 bottles on middle zone and 35 bottles on lower zone]
Bottle stacking diagrams available at caple.co.uk

OPTIONAL EXTRAS

- 6 Wine labels [WINELABEL]
 - Metallic handles available [see p.186 for full range]
 - Furniture doors [SSDOOR177] for WC1792 cooling trio *see below
- Visit caple.co.uk for full range

INSTALLATION

- Diagram [p.241]

SENSE IN-COLUMN SINGLE ZONE WINE CABINETS



WC6100BG



WC6100BS



WC6100GM



WC6100SS

PRODUCT CODE

Black Glass	WC6100BG
Black Steel	WC6100BS
Gunmetal	WC6100GM
Stainless Steel	WC6100SS

DIMENSIONS

h:600mm

PERFORMANCE

e Energy class G
Noise class D
Energy consumption 124kWh/y
Ambient temperature 16°C - 32°C
Temperature range 5°C - 18°C
Humidity range >60%RH
Quiet operation 43dB[A]

FINISH AVAILABLE

	Black Glass
	Black Steel
	Gunmetal
	Stainless Steel

GENERAL FEATURES

- Soft-open and close door
- Shelves can accommodate 750ml Bordeaux, Burgundy and Champagne bottles
- No-frost compressor cooling technology maintains a consistent temperature

FEATURES

SEAMLESS INTEGRATION

Our WC6100 wine cabinets have been designed to work with Sense or Sense Premium range, so you can create your perfect combination. See page 58 - 59.



SOFT OPEN + CLOSE DOOR

The hinge activates when the door is inches away from the open or closed position, allowing you to easily & silently shut the cabinet without disturbing the wine.



FINAL TOUCH

See page 190 for our collection of metallic handlesto add that final touch of luxury.



- Single temperature zone stores red, white or sparkling wine
- Touch controls and white LED display
- Electronic temperature control
- UV/heat-free white LED lighting [switchable]
- Vibration free
- Fan circulated cool air for even temperature distribution
- 4 Telescopic shelves and 1 base shelf
- 100% CFC/HFC free
- Toughened UV protected glass door
- Telescopic beech shelves

WC6100BG + WC6100BS UNIQUE FEATURES

- Black Glass door
- Black square handle

WC6100GM UNIQUE FEATURES

- Gunmetal door
- Square Black handle

WC6100SS UNIQUE FEATURES

- Stainless Steel door
- Square Stainless Steel handle

CAPACITY

- Stores max.30 Bordeaux style wine bottles 750ml
Bottle stacking diagrams available at caple.co.uk

OPTIONAL EXTRA

- Metallic handles available [see p.190 for full range]

INSTALLATION

- Diagram [p.241]

IN-COLUMN DUAL ZONE WINE CABINETS



WC6521BG



WC6511

PRODUCT CODE

Black Glass	WC6521BG
Stainless Steel	WC6511

DIMENSIONS

h:886mm

PERFORMANCE

e Energy class G
Noise level C
Energy consumption 140kWh/yr
Ambient temperature 16°C - 32°C
Temperature range upper zone 5°C - 10°C, lower zone 10°C - 18°C
Humidity range >65%RH
Quiet operation 39dB[A]

FINISH AVAILABLE

	Black Glass
	Stainless Steel

FEATURES

- Shelves can accommodate 750ml Bordeaux, Burgundy and Champagne bottles
- No-frost compressor cooling technology maintains a consistent temperature
- Dual stacked temperature zones, independently controlled [upper zone to serve, lower zone storage]
- Touch controls and white LED display
- UV/heat-free white LED lighting [switchable]
- Vibration free
- Beech shelves
- Fan circulated cool air for even temperature distribution
- Reversible door
- Heater raises internal temperature when external temperature drops
- High temperature and open door alarm
- Upper zone has 3 sliding shelves

- Lower zone has 3 sliding shelves and 1 sliding base shelf
- 100% CFC/HFC free
- Toughened UV protected glass door
- 2 Humidity control water tanks

WC6521BG UNIQUE FEATURE

- One piece Black Glass door
- Black square handle

WC6511 UNIQUE FEATURES

- One piece Stainless Steel door
- Stainless Steel square handle

CAPACITY

- Stores max. 41 Bordeaux style wine bottles 750ml [18 bottles on upper zone, and 23 bottles on lower zone]
- Bottle stacking diagrams available at caple.co.uk

OPTIONAL EXTRAS

- 6 Wine labels [WINELABEL]
 - Metallic handles available [see p.190 for full range]
 - Metallic grilles available [see p.191 for full range]
- Visit caple.co.uk for full range

INSTALLATION

- Diagram [p.241]

IN-COLUMN SINGLE ZONE WINE CABINETS



WC6411BG



WC6401

PRODUCT CODE

Black Glass	WC6411BG
Stainless Steel	WC6401

DIMENSIONS

h:455mm

PERFORMANCE

e Energy class F
Noise level C
Energy consumption 100kWh/yr
Ambient temperature 16°C - 32°C
Temperature range 5°C - 18°C
Humidity range >65%RH
Quiet operation 37dB[A]

FINISH AVAILABLE

	Black Glass
	Stainless Steel

FEATURES

- Shelves can accommodate 750ml Bordeaux and Burgundy bottles
- No-frost compressor cooling technology maintains a consistent temperature
- Single temperature zone for red, white or sparkling wine
- Touch control and white LED display
- UV/heat-free white LED lighting [switchable]
- Vibration free
- Beech shelves
- Fan circulated cool air for even temperature distribution
- Reversible door
- High temperature and open door alarm
- 3 Sliding shelves and 1 base shelf
- 100% CFC/HFC free
- Toughened UV protected glass door
- Humidity control water tank

WC6411BG UNIQUE FEATURES

- One piece Black Glass door
- Black square handle

WC6401 UNIQUE FEATURES

- One piece Stainless Steel door
- Stainless Steel square handle

CAPACITY

- Stores max. 21 Bordeaux style wine bottles 750ml
- Bottle stacking diagrams available at caple.co.uk

OPTIONAL EXTRAS

- 6 Wine labels [WINELABEL]
 - Metallic handles available [see p.190 for full range]
 - Metallic grilles available [see p.191 for full range]
- Visit caple.co.uk for full range

INSTALLATION

- Diagram [p.241]



Freestanding Wine Cabinets.

FLEXIBILITY

Freestanding wine cabinets offer great installation flexibility. You can either house them in units to give them the appearance of being built-in, or you can have them as a stand alone feature.

TRIPLE ZONE

The WF1552 & WF1553BG triple zones are independently controlled allowing you to keep your collection at the perfect temperature for storing and drinking.

WINE GLASS RACK

The WF1552 & WF1553BG also feature a wine glass rack. The glass rack allows you to convert some of your wine cabinet into storage for wine glasses or flutes, giving you the perfect chilled glass.

MAXIMUM STORAGE

With storage for 111 Bordeaux style bottles, the WF1552 & WF1553BG boast the largest storage capacity in our extensive collection.



FREESTANDING WINE CABINET

PRODUCT CODE

WF1553BG

DIMENSIONS

h:1766mm

PERFORMANCE

e Energy class G
 Noise class C
 Energy consumption 175kWh/yr
 Ambient temperature 16°C - 32°C
 Temperature range:
 Upper 5°C - 18°C
 Middle 5°C - 10°C
 Lower 10°C - 18°C
 Humidity range >65%RH
 Quiet operation 40dB[A]

FINISH AVAILABLE

Black Glass

FEATURES

- Freestanding or built-in installation with correct ventilation
- Shelves can accommodate 750ml Bordeaux, Burgundy and Champagne bottles
- Charcoal filter [x3]
- No-frost compressor cooling technology maintains a consistent temperature
- Easy glide beech shelves
- Touch controls and white LED display
- UV/heat-free white LED lighting [switchable]
- Fan circulated cool air for even temperature distribution
- 3 Humidity control water tanks
- Vibration free
- Reversible door
- 2 heaters raise internal temperature when external temperature drops
- High temperature and open door alarm
- Upper zone has 1 wine glass rack and 2 sliding shelves
- Middle zone has 2 sliding shelves and 1 display shelf

- Lower zone has 3 sliding shelves and 1 base shelf
- 100% CFC/HFC free
- Toughened UV protected glass door
- Black handle
- Wine labels and holders included
- Door lock
- Air ventilation through plinth grille

CAPACITY

- Stores max.111 Bordeaux style wine bottles 750ml [22 bottles in upper zone, 45 bottles in middle zone and 44 bottles in lower zone] If wine glass rack is replaced by WSHELF1, upper zone capacity increases to 44 bottles.
 Bottle stacking diagrams available at caple.co.uk

OPTIONAL EXTRAS

- 6 Wine labels [WINELABEL]
- 2 beech shelves [WSHELF1]
- Stainless Steel handle [HANDLE7]
- Replacement charcoal filter [WC1CF]

INSTALLATION

- Diagram [p.242]

FEATURES

WINE GLASS RACK

The top compartment includes an innovative wooden rack, allowing you to store glasses ready for the perfect chilled glass.





FREESTANDING WINE CABINET

PRODUCT CODE

WF1552

DIMENSIONS

h:1766mm

PERFORMANCE

Energy class G
Noise class C
Energy consumption
175kWh/yr
Ambient temperature
16°C - 32°C
Temperature range:
Upper: 5°C - 18°C
Middle: 5°C - 10°C
Lower: 10°C - 18°C
Humidity range >65%RH
Quiet operation 40dB[A]

FINISH AVAILABLE

Stainless Steel

FEATURES

- Freestanding or built-in installation with correct ventilation
- Shelves can accommodate 750ml Bordeaux, Burgundy and Champagne bottles
- Charcoal filter [x3]
- One piece Stainless Steel door
- No-frost compressor cooling technology maintains a consistent temperature
- Easy glide beech shelves
- Touch controls and white LED display
- UV/heat-free white LED lighting [switchable]
- Fan circulated cool air for even temperature distribution
- 3 Humidity control water tanks
- Vibration free
- Reversible door
- 2 heaters raise internal temperature when external temperature drops
- High temperature and open door alarm
- Upper zone has 1 wine glass rack and 2 sliding shelves

- Middle zone has 2 sliding shelves and 1 display shelf
- Lower zone has 3 sliding shelves and 1 base shelf
- 100% CFC/HFC free
- Toughened UV protected glass door
- Stainless Steel handle
- Wine labels and holders included
- Door lock
- Air ventilation through plinth grille

CAPACITY

- Stores max.111 Bordeaux style wine bottles 750ml [22 bottles in upper zone, 45 bottles in middle zone and 44 bottles in lower zone] If wine glass rack is replaced by WSHELF1, upper zone capacity increases to 44 bottles.
- Bottle stacking diagrams available at caple.co.uk

OPTIONAL EXTRAS

- 6 Wine label and holders [WINELABEL]
 - 2 beech shelves [WSHELF1]
 - Replacement charcoal filter [WC1CF]
- Visit caple.co.uk for full range

INSTALLATION

- Diagram [p.242]

FEATURES

WINE GLASS RACK

The top compartment includes an innovative wooden rack, allowing you to store glasses ready for the perfect chilled glass.



FREESTANDING WINE CABINET

PRODUCT CODE

WF334

DIMENSIONS

h:840mm

PERFORMANCE

Energy class G
Noise class C
Energy consumption
118kWh/yr
Temperature range
5°C - 18°C
Ambient temperature
16°C - 32°C
Humidity range >65%RH
Quiet operation 39dB[A]

FINISH AVAILABLE

Stainless Steel

FEATURES

- Moulded shelf supports
- Shelves can accommodate 750ml Bordeaux, Burgundy and Champagne bottles
- Fan circulated cool air for even temperature distribution
- No-frost compressor cooling technology maintains a consistent temperature
- Single temperature zone for red or white wine
- Electronic temperature control
- UV/heat-free white LED lighting [switchable]
- Stainless Steel square handle
- One piece Stainless Steel door
- Vibration free
- Reversible door
- Interior light
- Beech shelves

- 3 Double stacked shelves and 1 half shelf
- 100% CFC/HFC free
- Toughened UV protected glass door
- Humidity control water tank
- Black cabinet interior and exterior
- Top and side heat dispersion

CAPACITY

- Stores max. 35 Bordeaux style wine bottles 750ml [6 bottles on top shelf, 10 bottles double stacked on middle two shelves and 9 bottles double stacked on the bottom shelf]

OPTIONAL EXTRA

- 6 wine labels and holders [WINELABEL]
- Visit caple.co.uk for full range

INSTALLATION

- Diagram [p.242]

Handles + Accessories.



HANDLES

HANDLE7	[Stainless Steel]
HANDLE7BK	[Black]
HANDLE7CO	[Copper]
HANDLE7GD	[Gold]

- Square handle for wine cabinets [excluding WC6401 and WC6411BG]
- Width: 525mm
- Depth: 39mm



HANDLES

HANDLE9BK	[Black]
HANDLE9CO	[Copper]
HANDLE7GD	[Gold]

- Square handle for WC6401 and WC6411BG
- Width: 347mm
- Depth: 39mm



HANDLES

HANDLE10BK	[Black]
HANDLE10CO	[Copper]
HANDLE10GD	[Gold]

- Square handle for WC6100's, 60cm ovens + 45cm wine cabinets
- Width: 525mm
- Depth: 46mm

PLINTH GRILLES + VENTS



- FP300BK**
- Black Glass
 - W:300mm H:78mm
 - Suitable for 300mm wine cabinets

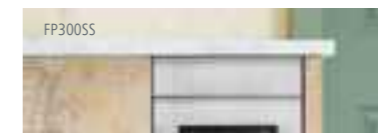

- FP300SS**
- Stainless Steel [Shown]
 - W:300mm H:78mm
 - Suitable for 300mm wine cabinets



- FP300GM**
- Gunmetal [Shown]
 - W:300mm H:78mm
 - Suitable for 300mm wine cabinets



- FP600BK**
- Black Glass [Shown]
 - W:600mm H:78mm
 - Suitable for 600mm wine cabinets



- FP600SS**
- Stainless Steel
 - W:600mm H:78mm
 - Suitable for 600mm wine cabinets

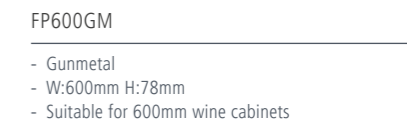

- FP600GM**
- Gunmetal
 - W:600mm H:78mm
 - Suitable for 600mm wine cabinets



- GRILL/SENSE600**
- Stainless Steel integrated plinth grille
 - W:525mm H:60mm D:18mm
 - Suitable for 600mm wine cabinets



- GRILL/CLASS601**
- Stainless Steel full height plinth grille and brackets
 - W:597mm H:140mm D:55mm
 - Suitable for 600mm wine cabinets



- GRILL/SENSE300**
- Stainless Steel integrated plinth grille
 - W:230mm H:80mm D:18mm
 - Suitable for 300mm wine cabinets



- GRILL/CLASS301**
- Stainless Steel full height plinth grille and brackets
 - W:297mm H:140mm D:55mm
 - Suitable for 300mm wine cabinets



- GRILL/SENSE6/GM**
- Gunmetal integrated plinth grille
 - W:525mm H:60mm D:18mm
 - Suitable for 600mm wine cabinets



- GRILL/CLASS6/GM**
- Gunmetal Steel full height plinth grille and brackets
 - W:597mm H:140mm D:55mm
 - Suitable for 600mm wine cabinets



- GRILL/SENSE3/GM**
- Gunmetal integrated plinth grill
 - W:230mm H:80mm D:18mm
 - Suitable for 300mm wine cabinets



- GRILL/CLASS3/GM**
- Gunmetal full height plinth grille and brackets
 - W:297mm H:140mm D:55mm
 - Suitable for 300mm wine cabinets



- GRILL/SENSE6/BS**
- Black Steel integrated plinth grille
 - W:525mm H:60mm D:18mm
 - Suitable for 600mm wine cabinets



- GRILL/CLASS6/BS**
- Black Steel full height plinth grille and brackets
 - W:597mm H:140mm D:55mm
 - Suitable for 600mm wine cabinets



- GRILL/SENSE3/BS**
- Black Steel integrated plinth grill
 - W:230mm H:80mm D:18mm
 - Suitable for 300mm wine cabinets



- GRILL/CLASS3/BS**
- Black Steel full height plinth grille and brackets
 - W:297mm H:140mm D:55mm
 - Suitable for 300mm wine cabinets



- GRILL/SENSE3/GD**
- Gold full height integrated plinth grille
 - W:230mm H:80mm D:18mm
 - Suitable for 300mm wine cabinets



- GRILL/SENSE6/GD**
- Gold plinth integrated plinth grille
 - W:525mm H:60mm D:18mm
 - Suitable for 600mm wine cabinets



- GRILL/CLASS150**
- Stainless Steel full height plinth grille and brackets
 - W:150mm H:140mm D:70mm
 - Suitable for 150mm wine cabinets

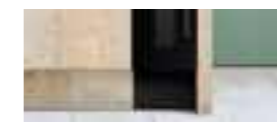

- GRILL/CLASS15BS**
- Black Steel full height plinth grille and brackets
 - W:150mm H:140mm D:70mm
 - Suitable for 150mm wine cabinets



- GRILL/SENSE15BS**
- Black Steel plinth grille and brackets
 - W:145mm H:85mm D:18mm
 - Suitable for 150mm wine cabinets



WINE LABELS

WINELABEL

- Six wine label holders
- Supplied with 6 pieces of white card
- Not suitable for 150mm wine cabinets



STAINLESS STEEL DOOR

SSDOOR177DOD

- Stainless Steel furniture door
- 1788mm x 595mm x 20mm
- Suitable for RiL1800 and RIF1801



STAINLESS STEEL DOOR

SSDOOR177

- Stainless Steel furniture door
- 1788mm x 595mm x 20mm
- Suitable for RiL1796 and RIF1797



Washing

DISHWASHERS	196
WASHING MACHINES	204
WASHER DRYER	208
TUMBLE DRYERS	210



Taking the Chore out of Washing.

Who says that functional objects can't look fantastic? That's why we've designed our dishwasher and laundry appliances with an eagle eye on performance and style.

Caple is renowned for ultra stylish looks, hi-tech and all-round ease of use. With fast, efficient clothes washing and drying and sparkling clean dishes, our appliances will always get the job done beautifully with minimal effort.

WASH HOWEVER YOU WISH

Our range of washing appliances gives you all the options you need to fit in with your kitchen and your budget. What's on your wish list?

An appliance that makes the most of minimal space? One that can cope with a large family? Or super stylish looks? We tick all your boxes.

Our dishwashers are exceptionally versatile, using clever technology to deal with any type of load. Our washing machines and washer dryers make light work of all your laundry needs with features like allergy care, stain reduction and extra large doors. What's more, Caple tumble dryers can be kept neatly behind furniture doors for a flawless finish.



Dishwashers.

Ask many people to name a household item they wouldn't want to live without, and many will answer "dishwasher".

Our reliable dishwashers will give you load after load of squeaky-clean pans and glassware that sparkles like new.



Performance with Shine.

Whether it's a quick wash or something more heavy-duty, every Cuple dishwasher is designed to perform well. All models are fully integrated to tuck away behind your kitchen doors.

AUTO DOOR OPEN

The door automatically opens at the end of a cycle releasing steam to improve drying.

INTERNAL LED LIGHT

Activated when the door is opened, it illuminates the inside.

REDUCE YOUR WATER + ENERGY USAGE

The Half Load function on our models is ideally suited to small loads, unlike traditional Half Load programmes [which usually only use one basket] reducing energy and water use.

DELAY TIMER

Allows you to delay the start time for between 1-24 hours.

AQUASTOP

Automatically cuts off the water at the first sign of a leak, helping to avoid costly water damage.

AUTO WASH

Auto wash on Di654 has sensors checking the level of cleanliness of the load, saving you time, energy and water.

WATER CONSUMPTION

The entire range has low water consumption figures, which is not only great for the environment but your pocket also. The Auto Wash programme on the Di482 uses an astonishingly low 9 litres of water.

ALTERNATIVE WASH

Available on a selection of models the alternative wash allows you to select either the upper or lower baskets for the load. You'll save water and energy with smaller loads.

SLIDING FURNITURE DOOR SYSTEM

The Di654's sliding door mechanism, allows a full height or reduced height plinth to be fitted without cutting.

ADJUSTABLE UPPER BASKET

Look out of for models with adjustable upper basket. You can change the height of the upper basket [even with full loads] with the simple release of two conveniently placed levers.

POWER WASH

Power Wash, exclusive to the Di654, when used with either intensive, normal, economy, glass and one hour express programmes, helps break through heavily soiled loads by increasing washing temperature and duration.

FEATURES

FLEXIBLE CUTLERY TRAY

Why not opt for an adjustable cutlery tray. The tray sits at the top of the dishwasher freeing up more space in the lower basket. On the 600mm

models you can choose from four set-up options, [shown below] depending on what is in the basket below.



FULLY INTEGRATED SLIDING DOOR DISHWASHER



FEATURES

EXPRESS WASH

Save time with the Express Wash feature, reducing programme duration for selected programmes and ensuring efficient dishwashing.

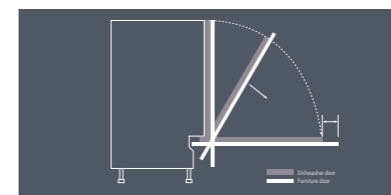

SLIDING FURNITURE DOOR SYSTEM

The Di654's sliding door mechanism, allows a full height or reduced height plinth to be fitted without cutting.



INNOWASH SPRAY ARM

Experience advanced cleaning with a 360° revolving spray arm designed to effectively eliminate stubborn, baked-on food from your dishes.



WINE RACK

Safely place your wine glasses in the upper and lower racks or the freestanding holder, utilising a specialised design to secure them at the perfect angle for thorough cleaning.

PRODUCT CODE

Di654

DIMENSIONS

w:600mm

PERFORMANCE

e Energy class B
Noise class B
Max. noise level 42dB[A]
Energy consumption per 100 cycles 65kWh
Water consumption per cycle [economy] 9.8 Litres

FINISH AVAILABLE

Stainless Steel control panel with LCD display

PROGRAMMES

8 Programmes
Universal/45-55°C
Eco/40-50°C
90min/50-60°C
Auto/45-55°C
Hygiene/72°C
Party/35°C
Glass/50°C
Self cleaning/60°C

FUNCTIONS

- Alternative wash
- Express Wash
- Extra Drying
- Power Wash
- Auto Open [switchable On/Off]
- Delayed timer 1-24hr

FEATURES

- Sliding furniture door system
- Auto opening door to assist drying
- 14 Place settings
- Turbo Dry
- Max. plate diameter 30cm
- Stainless Steel inner door and interior
- Stainless Steel touch control panel
- Programme status light
- Internal light
- Top cutlery tray
- Deluxe Titanium grey baskets
- Electronic salt and rinse aid warning light
- Cold water connection
- 3 spray levels
- 360° spray arm
- Hidden heating element
- Easy adjustable upper basket
- Sliding door dispenser
- Wine glass holder
- Anti-bacterial filter system
- 6 Level water softening system
- Water overflow protection system
- Aquastop
- Brushless Motor
- Upper and lower wine glass racks with rubber grips [built into the baskets]
- Oven tray holder

OPTIONAL EXTRAS

- Cutlery basket [CBASKET1]

INSTALLATION

- Diagram [p.242]
- Voltage 220-240V
- Rated load 2.1kW
- Fuse rating 13A

FULLY INTEGRATED DISHWASHER



PRODUCT CODE

Di632

DIMENSIONS

w:600mm

PERFORMANCE

e Energy class D
Noise class C
Max. noise level 49dB
Energy consumption per 100 cycles 82kWh
Water consumption per cycle [economy] 11 Litre

FINISH AVAILABLE

Black gloss door top control panel

PROGRAMMES

6 Programmes

Universal/55°C
Intensive/65°C
Eco/50°C
90min/55°C
Glass/50°C
Rapid 30min/40°C

FUNCTIONS

- Delay timer 3, 6 or 9hrs
- Half load

FEATURES

- 12 Place settings
- Auto opening door to assist drying
- Max. plate diameter 30cm
- Stainless Steel inner door and interior
- Plastic tub base
- Cutlery basket
- Electronic salt and rinse aid warning light
- Upper wine glass rack
- Titanium grey baskets
- Cold water connection
- Hidden heating element
- Adjustable upper basket
- Anti-bacterial filter system
- 6 Level water softening system
- Water overflow protection system

OPTIONAL EXTRAS

- Wine glass holder [DI/WINERACK]

INSTALLATION

- Diagram [p.242]
- Voltage 230V
- Rated load 1.93kW
- Fuse rating 13A

FULLY INTEGRATED DISHWASHER



PRODUCT CODE

Di642

DIMENSIONS

w:600mm

PERFORMANCE

e Energy class D
Noise class C
Max. noise level 47dB
Energy consumption per 100 cycles 85kWh
Water consumption per cycle [economy] 11 Litres

FINISH AVAILABLE

Stainless Steel control panel with electronic display

PROGRAMMES

7 Programmes

Universal/55°C
Intensive/65°C
Eco/50°C
90min/55°C
Glass/50°C
Rapid/40°C
Pre-Wash

FEATURES

AUTO DOOR OPEN

The door automatically opens at the end of a cycle releasing steam to improve drying.



FUNCTIONS

- Delayed timer 1-24hr
- Half load

FEATURES

- 14 Place settings
- Auto opening door to assist drying
- Max. plate diameter 30cm
- Stainless Steel inner door and interior
- Top cutlery tray
- 3 spray levels
- Upper wine glass rack
- Titanium grey baskets
- Cold water connection
- Hidden heating element
- Easy adjustable upper basket
- Anti-bacterial filter system
- Electronic salt and rinse aid warning light
- 6 Level water softening system
- Water overflow protection system

OPTIONAL EXTRAS

- Wine glass holder [DI/WINERACK]

INSTALLATION

- Diagram [p.242]
- Voltage 230V
- Rated load 1.93kW
- Fuse rating 13A



FULLY INTEGRATED DISHWASHER



PRODUCT CODE

Di482

DIMENSIONS

w:450mm

PERFORMANCE

e Energy class D
Noise class C
Max. noise level 49dB
Energy consumption per 100 cycles 63kWh
Water consumption per cycle [economy] 9 Litres

FINISH AVAILABLE

Black gloss door top control panel

PROGRAMMES

5 Programmes

Universal/55°C
Intensive/65°C
Eco/45°C
90min/55°C
Rapid/40°C

FUNCTIONS

- Delayed timer 3, 6 or 9hrs

FEATURES

- 9 Place settings
- Auto opening door to assist drying
- Max. plate diameter 30cm
- Stainless Steel inner door and interior
- Cutlery basket
- Titanium grey baskets
- Salt and rinse aid warning light
- Cold water connection
- Hidden heating element
- Adjustable upper basket
- Sliding door dispenser
- Anti-bacterial filter system
- Upper wine glass rack
- Upper basket cutlery rack
- Water overflow protection system

INSTALLATION

- Diagram [p.242]
- Voltage 230V
- Rated load 1.93kW
- Fuse rating 13A

FEATURES

AUTO DOOR OPEN

The door automatically opens at the end of a cycle releasing steam to improve drying.



Laundry.

A reliable washing machine and tumble dryer is an absolute must for any family. We've taken things further, with a range that's packed with features, good looks and performance.





Washing Machines.

Choose from a selection of integrated machines that tuck neatly away. Whichever you opt for, you can be sure it will do the job in style. All our machines use the most advanced technology to make laundry day just that bit easier.



DIGITAL DISPLAY

Included on all models. Shows the programme phase, spin speed and any extra functions selected.



15-MINUTE RAPID WASH

A super-speedy programme designed for small, everyday loads—perfect for when you're in a hurry.



BRUSHLESS MOTOR

Enjoy a quieter laundry experience. The brushless motor significantly reduces noise compared to standard motors, making every wash more peaceful.



EXTRA LARGE DOORS

Makes loading and unloading much easier.

INTEGRATED 9KG WASHING MACHINE



PRODUCT CODE

WMI4001

DIMENSIONS

w:600mm

CAPACITY

9kg washing capacity

PERFORMANCE

e Energy class A
Spin efficiency B
Max. spin speed 1400rpm
Noise class B
Energy consumption
49kWh/100 cycles
Water consumption
46litres/cycle
Max. noise level 75dB

FINISH AVAILABLE

 White

PROGRAMMES

15 Programmes

Cotton 20°C
Jeans
Rapid 14/30/44 mins.
Eco 40°C - 60°C
Rinse & spin
Shirts
Synthetic
Dark colours
Delicate
Whites

Silk
Wool
Hand wash
Drain
Spin

8 Options

Delay timer
[up to 24hrs]
Speed
Temperature
Extra rinse
Hygiene+
Stain
Rapid
Start/Pause

FEATURES

- Cold fill
- Prewashing
- Speed washing
- Easy iron
- Extra rinse
- Anti-overflow protection
- Foam control
- Programme time remaining
- Door safety lock
- Low noise brushless motor
- Child lock
- Red LED display

INSTALLATION

- Diagram [p.243]
- Rated load 1.6kW
- Fuse rating 13A

INTEGRATED 8KG WASHING MACHINE



PRODUCT CODE

WMI3007

DIMENSIONS

w:600mm

CAPACITY

8kg washing capacity

PERFORMANCE

e Energy class A
Spin efficiency B
Max. spin speed 1400rpm
Noise Class A
Energy consumption
47kWh/100cycles
Water consumption
48Litres/cycle
Max. noise level 72dB

FINISH AVAILABLE

 White

PROGRAMMES

16 Programmes

15min quick wash
Rapid 45
20°C
Jeans
Eco 40-60
Steam Wash
Rinse & spin
Spin Only
Baby Care
Wool

Delicate
Mixed
Synthetics
Sports
Cotton
My cycle

6 Options

Delay timer [up to 24hrs]
Pause
Spin speed selection
Temperature selection
Pre wash
Extra rinse

FEATURES

- Child lock
- Alarm On/Off
- Memory function
- Cold fill
- 15mins fast wash
- Digital display
- 300mm large door
- Door safety lock
- Programme time remaining
- Variable spin speed
- Stainless Steel
Diamond+ drum
- Anti-overflow protection

INSTALLATION

- Diagram [p.243]
- Rated load 1.95kW
- Fuse rating 10A



INTEGRATED 8KG WASHING MACHINE



PRODUCT CODE

WMI3100

DIMENSIONS

w:600mm

CAPACITY

8kg washing capacity

PERFORMANCE

e Energy class A
Noise Class B
Spin efficiency B
Max. spin speed
1400rpm
Water consumption
per cycle 48Litres
Energy consumption
per 100cycles 47kWh
Max. noise level 74dB

FINISH AVAILABLE

 White

PROGRAMMES

15 Programmes

Rapid 15min
Jeans
Fast 60min
Eco 40-60°

Rinse
Spin / Drain
Wool
Mixed
Colours
Cotton
Cotton 20°C
Cotton Prewash
Allergy safe
Outdoor
Hand wash

6 Option

Delay timer [up to
23hrs]
Spin Speed selection
Temperature selection
Rapid
Easy iron
Start / Pause

FEATURES

- Child lock
- Cold fill
- Speed washing
- Easy iron
- Touch control
- Door safety lock
- Programme time remaining
- End of programme
tone

- Variable spin speed
- Low noise brushless motor
- Foam control
- Unbalance control
- Anti-overflow protection
- Appliance door LH hinged
- Furniture door LH or
RH hinged

INSTALLATION

- Diagram [p.243]
- Rated load 2.1kW
- Fuse rating 10A

FEATURES

TOUCH CONTROL
LED DISPLAY

The touch screen allows you to easily select wash options through a seamless white LED display.

BRUSHLESS MOTOR

Enjoy a quieter laundry experience. The brushless motor significantly reduces noise compared to standard motors, making every wash more peaceful.

15-MINUTE
RAPID WASH

A super-speedy programme designed for small, everyday loads—perfect for when you're in a hurry.



Washer Dryer.

Our integrated washer dryer offers multiple programmes that are easy to operate, meeting all your laundry needs with minimal fuss.

Caple's washer dryer use advanced technology to make every task effortless.

TOUCH CONTROL LED DISPLAY

The touch screen allows you to easily select wash options through a seamless white LED display.

DOOR SAFETY LOCK

Our machine operates at high temperatures during mid-cycle. The door will remain locked until the cycle has ended.

STAIN REDUCTION

Uses advanced technology to maximise cleaning action, keeping your whites looking fresher for longer.

INTEGRATED 8/5KG WASHER DRYER



PRODUCT CODE

WDI3310

DIMENSIONS

↔ w:600mm

CAPACITY

8kg washing, 5kg drying

PERFORMANCE

e Wash class A
Wash and dry class E
Spin efficiency class B
Max. spin speed 1400rpm
Noise class B
Energy consumption per 100 wash cycles 47kWh
Energy consumption per 100 wash and dry cycles 326kWh
Water consumption of wash cycle 48litres
Water consumption of wash and dry cycle 80litres
Max. noise level 75dB

FINISH AVAILABLE

White

PROGRAMMES

15 Programmes

Rapid 15min
ECO 40-60
Fast 60min
Cotton
Cotton Dry
Cotton 20°C
Allergy safe
Synthetic
Quick wash & dry
Cotton wash & dry
Rinse
Spin & Drain
Wool & Silk
Duvet
Gentle Dry

6 Options

Delay timer [23hrs]
Pause
Spin speed selection
Temperature selection
Time Dry
Dry level

FEATURES

- Child lock
- Cold fill
- Low noise brushless motor
- Touch control
- Door safety lock
- Programme time remaining
- End of programme tone
- Variable spin speed
- Automatic variable load
- Anti-overflow protection
- Appliance door LH hinged
- Furniture door LH or RH hinged

INSTALLATION

- Diagram [p.243]
- Rated load 1.85kW
- Fuse rating 10A

FEATURES

15-MINUTE RAPID WASH

A super-speedy programme designed for small, everyday loads—perfect for when you're in a hurry.



Tumble Dryer.

We want your lives to be easier. Caple's intelligent tumble dryer makes sure you always have a pile of soft, freshly-laundered garments ready when you need them.

VENTILATION

Ensure your tumble dryer is well vented and the plinth is notched correctly. For a discreet and seamless finish, use an integrated plinth grilles to cover the aperture.

It has all the functionality of a freestanding model but with the seamless integration of a built in tumble dryer. Caple are one of the few brands to have a tumble dryer with Heat Pump Technology that can also be built in.

INTEGRATED 7KG HEAT PUMP TUMBLE DRYER



PRODUCT CODE

TDi4001

DIMENSIONS

↔ w:600mm

CAPACITY

7kg dryer capacity

PERFORMANCE

e Energy class A+
 Condensation efficiency class B
 Annual energy consumption 269kWh/yr
 Max. noise level 67dB

FINISH AVAILABLE

White

FUNCTIONS

- Delay [Up to 24 hr]
- Memory
- 4 Dry levels
- Anti-crease
- Timer selection
- Lock
- Start/pause

OPTIONS

15 Programmes

- Cotton
- Whites
- Synthetics
- Small load
- Mix & dry
- Jeans
- Sport
- Feather
- Coloured
- Shirts
- Delicates
- Wool
- Anti-allergy
- Pre iron
- Refresh

FEATURES

- Heat pump tumble dryer
- Sensor drying
- Reverse tumble action
- Red LED display
- In door water container

OPTIONAL EXTRA

- Stainless Steel universal inset plinth grille [GRILL/SENSE300]

INSTALLATION

- Diagram [p.243]
- Voltage 220-240V
- Rated load 0.9kW
- Fuse rating 13A

FEATURES

HEAT PUMP DRYER

Conventional tumble dryers work by releasing the hot air used to dry clothes, whereas heat pump technology conserves and reuses it. This is one of the many reasons heat pump technology has been used in Switzerland and Germany for about 13 years.

WHAT ARE THE BENEFITS?

Heat pump tumble dryers are much better for the environment and cheaper to run, with heat pump technology using almost 50% of the energy used by conventional models [C-rated]. Moreover, since it uses an energy efficient heat exchange system, the air temperature inside the drum is considerably lower than conventional dryers, which provides a better protection for clothes.

HOW DOES IT WORK?

Heat pump tumble dryers have a condenser that separates water from the warm air that passes over the wet clothes and puts it in a water tank. The remaining dry warm air is then pumped back through the drum, re-using it to help the clothes dry faster. This makes them by far the most energy efficient of all the tumble dryer types available.

Plinth Heaters.

Choose from hydronic or electric models [which are plumbed into the central heating or stand-alone, respectively] and Stainless Steel or white grills.

Look out for plinth heaters that can also blow out cool air on warm days [or when you can't stand the heat but have to stay in the kitchen!]. A neat way of warming your kitchen.



PLINTH HEATERS



PRODUCT CODE

PH500H

DIMENSIONS

↔ Grille: 495 x 100mm
 Heater: 322 x 380mm
 [including pipe work]
 Plinth cut out: 360 x 96mm

FUNCTIONS

- 500mm hydronic plinth heater [central heating]
- Stainless Steel grille
- 2 speed fan
- Summer setting [fan circulates air round the room]
- Up to 24% more efficient than standard radiators
- Auto switch on
- Easy install
- Low noise

CONNECTIONS

- Fuse rating: 3amp
- Voltage: 220-240 / 50hz
- Heat output: 3057 - 3979 Btu [0.9 - 1.17kW]
- Maximum working pressure: 8bar [1Mpa]

OPTIONAL EXTRAS

- White plinth grille available [PHHGRILL/WH]
- Visit caple.co.uk for full range

INSTALLATION

- Diagram [p.243]



PRODUCT CODE

PH501E

DIMENSIONS

↔ Grille: 495 x 100mm
 Heater: 323 x 202mm
 Plinth cut out:
 360 x 96mm

FUNCTIONS

- 500mm electric plinth heater
- Stainless Steel grille
- 2 speed fan
- Easy install
- Low noise

FEATURES

- Wall thermostat included

CONNECTIONS

- Fuse rating: 10amp
- Voltage: 220-240 / 50hz
- Heat output: 940 -1990w

OPTIONAL EXTRAS

- White plinth grille available [PHHGRILL/WH]
- Visit caple.co.uk for full range

INSTALLATION

- Diagram [p.243]

FEATURES

WHITE GRILLES

Optional extra plinth grille finished in white.
 PHEGRILL/WH
 PHHGRILL/WH



Food Waste Disposal.



A waste disposer hidden away under the sink can help you recycle your food scraps and leftovers like potato peelings, chicken bones, egg shells and tea bags. It's clean, it's green and it leaves less to clutter up your bin. It also reduces any decomposing food odours.

It couldn't be easier or more convenient to use. Simply turn on the cold tap and the disposer then empty everything into the sink. The disposer grinds the food waste into fine particles and flushes the waste away down the drain.

Since more than 25% of household refuse is food, that means much less rubbish to take away and clog up our landfill sites. It also means a reduction in the amount of greenhouse gases emitted.

Waste from your disposer can actually be recycled into a soil conditioner once it reaches the water treatment plant, so you will be making a positive contribution to your environment.

All models carry a lifetime corrosion proof guarantee, this warranty covers against failure due to corrosion.

PREMIUM FEATURES

The lightweight and compact design of the WDU125 features easy mount installation and 1.25hp motor and grinding system with a superior torque grind speed for a long system life and maximum power.

BIO SHIELD

The Bio Shield odour protection is treated with antimicrobial agent to provide ultimate protection against the growth of bacteria and subsequent odours.

All models carry a lifetime corrosion proof guarantee, this warranty covers against failure due to corrosion.

FOOD WASTE DISPOSAL UNITS



PRODUCT CODE
WDU050

DIMENSIONS
 w:175mm
 d:175mm
 h:372mm

FEATURES



- 0.5hp waste disposal unit
- Continuous feed
- High speed magnet motor
- Overload protection
- Corrosion resistant 3 stage grinding system
- Easy mount installation
- Sound insulation
- 2 Year guarantee
- Fits standard 90mm waste outlets

OPTIONAL EXTRAS

- Basket strainer waste decorative cover [CWC2]
Visit caple.co.uk for full range



PRODUCT CODE
WDU060

DIMENSIONS
 w:132mm
 d:132mm
 h:354mm

FEATURES



- 0.5hp waste disposal unit
- Continuous feed
- High speed magnet motor
- Overload protection
- Corrosion resistant 3 stage grinding system
- Bio Shield odour protection
- Easy mount installation
- 2 Year guarantee
- Fits standard 90mm waste outlets
- Fits sinks up to a thickness of 23mm [an extended flange is available for sinks up to 45mm thick]
- Air switch included

OPTIONAL EXTRAS

- Extended flange [EX/WDU125]
- Basket strainer waste decorative cover [CWC2]
Visit caple.co.uk for full range



PRODUCT CODE
WDU080

DIMENSIONS
 w:219mm
 d:219mm
 h:404mm

FEATURES

- 0.75hp waste disposal unit
- Continuous feed
- High speed magnet motor
- Overload protection
- Corrosion resistant 3 stage grinding system
- Bio Shield odour protection
- Easy mount installation
- 2 Year guarantee
- Fits standard 90mm waste outlets
- Fits sinks up to a thickness of 23mm [an extended flange is available for sinks up to 45mm thick]
- Stainless Steel stopper
- Air switch included

OPTIONAL EXTRAS

- Extended flange [EX/WDU125]
- Basket strainer waste decorative cover [CWC2]
Visit caple.co.uk for full range



PRODUCT CODE
WDU125

DIMENSIONS
 w:220mm
 d:220mm
 h:439mm

FEATURES

- Premium 1.25hp waste disposal unit
- Continuous feed
- High speed permanent magnet motor
- Overload protection
- Corrosion resistant 3 stage grinding system
- Bio Shield odour protection
- Easy mount installation
- Sound insulation
- 3 Year guarantee
- Fits standard 90mm waste outlets
- Fits sinks up to a thickness of 23mm [an extended flange is available for sinks up to 45mm thick]
- Stainless Steel stopper
- Air switch included

OPTIONAL EXTRAS

- Extended flange [EX/WDU125]
- Basket strainer waste decorative cover [CWC2]
Visit caple.co.uk for full range

Installation Diagrams.

SINGLE OVENS

C2601 / C2600 / C2403 / C2402 / C2106 / C2105 / C2101 / C2362

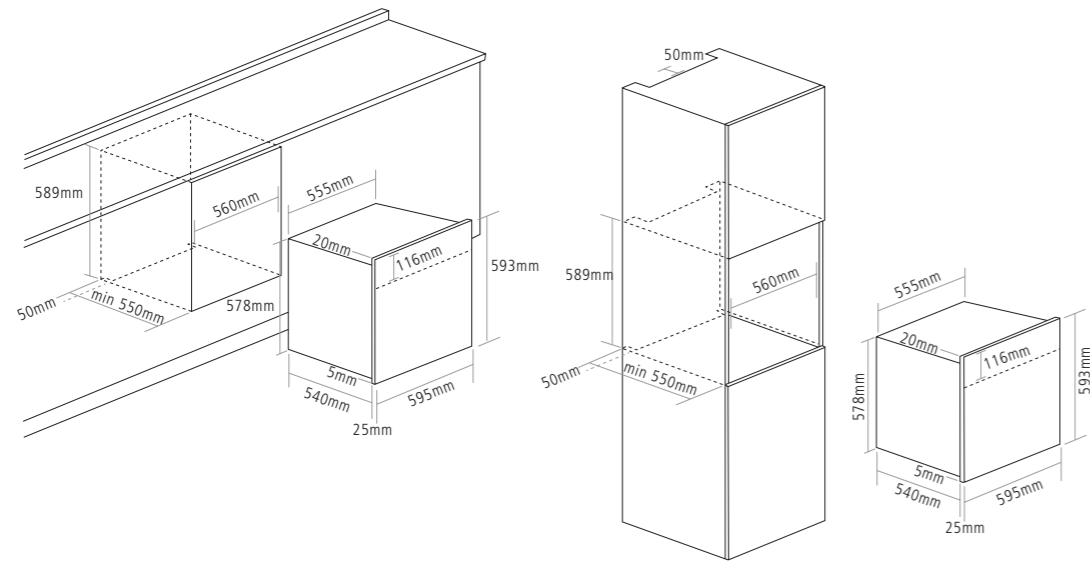

C2902

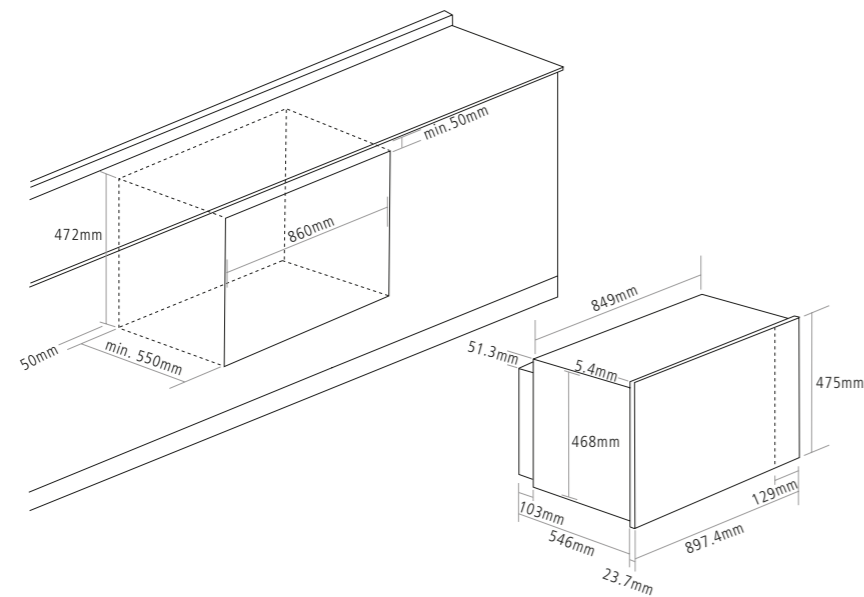

We recommend that when installing a stack or quad of products, a pair of our installation brackets [OVEN/BRACKETS2] are purchased to support the upper product ensuring a seamless fit for each appliance when one is on top of the other.

SINGLE OVENS

C2239 / C2237 / C2234 / C2234BK / C2231 / C2220

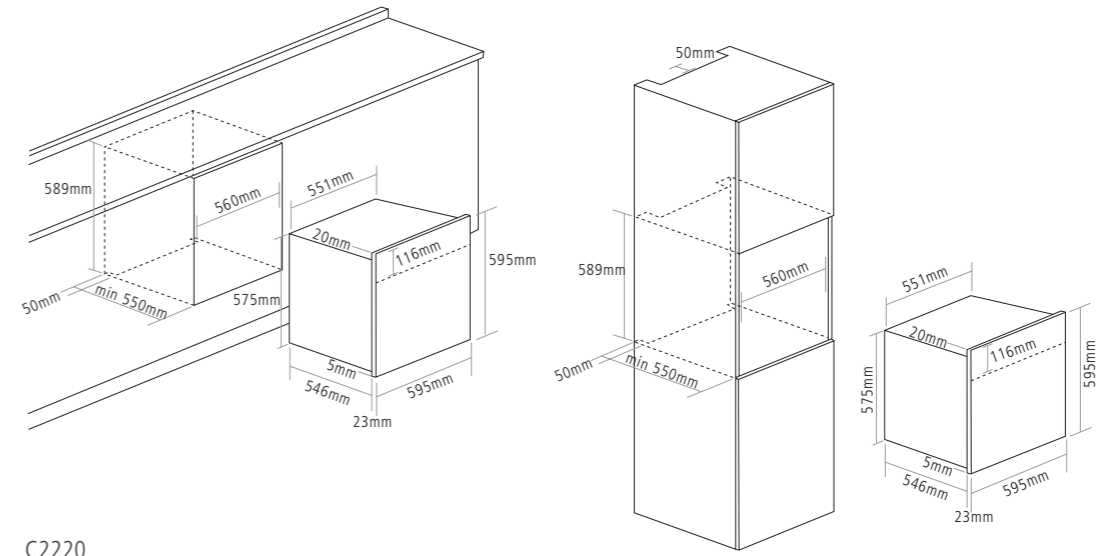

C2220

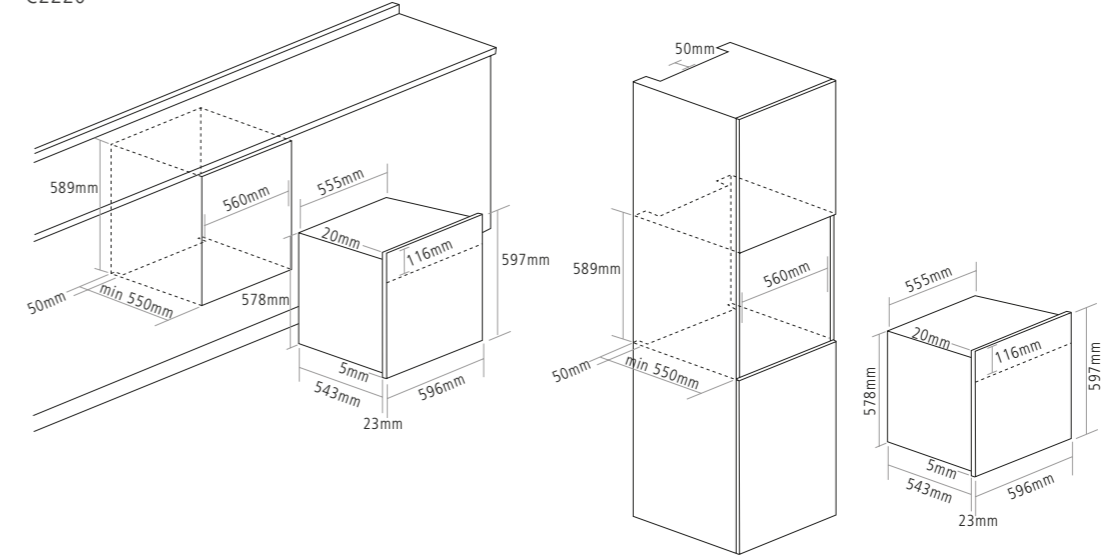

DOUBLE OVENS

C3371 / C3249 / C3246

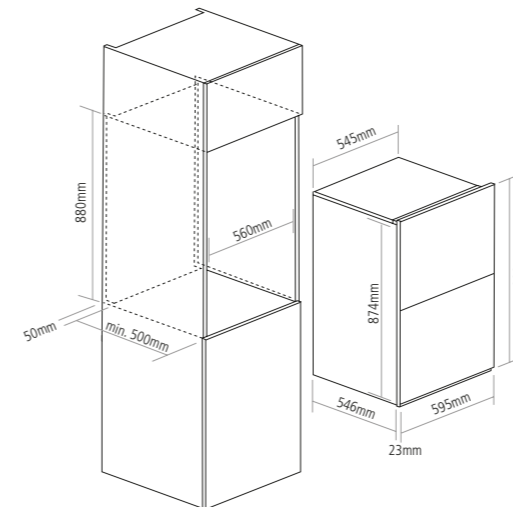

We recommend that when installing a stack or quad of products, a pair of our installation brackets [OVEN/BRACKETS2] are purchased to support the upper product ensuring a seamless fit for each appliance when one is on top of the other.

BUILT-UNDER DOUBLE OVEN

C4246

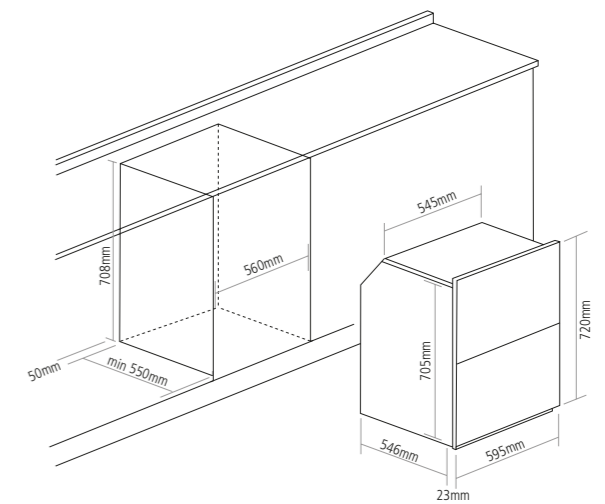

STEAM OVENS

SO111

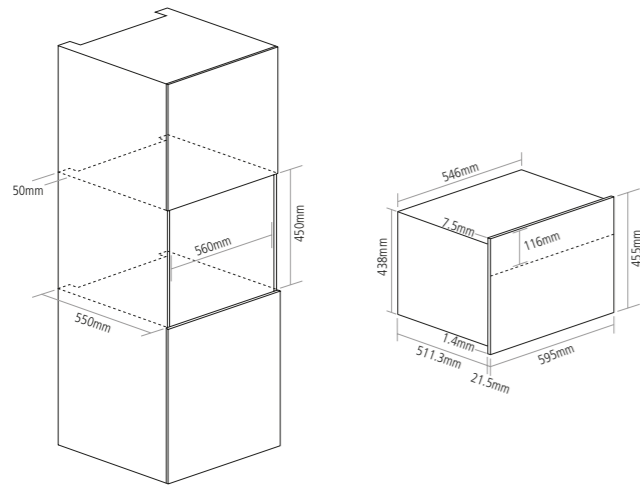

MICROWAVES

CMS260 / CM111 / CM1081BG

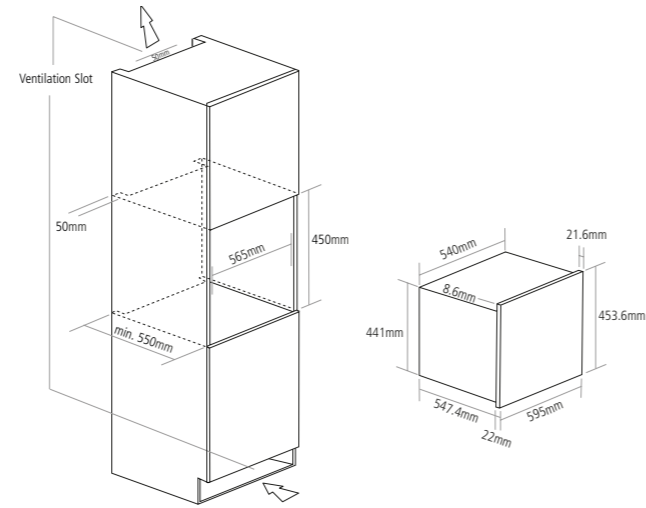

CM126

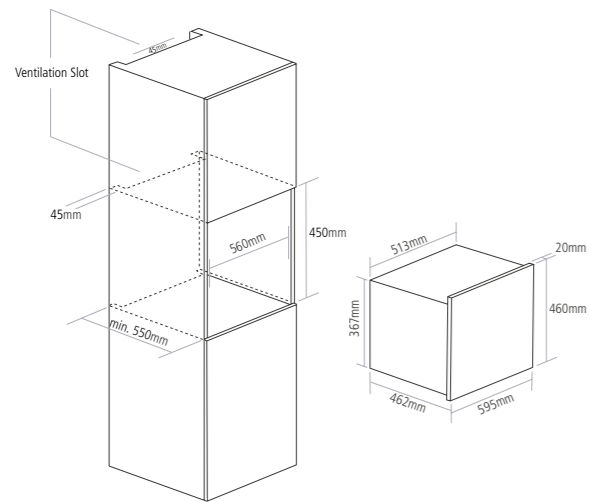

CM108SS / CM108BK

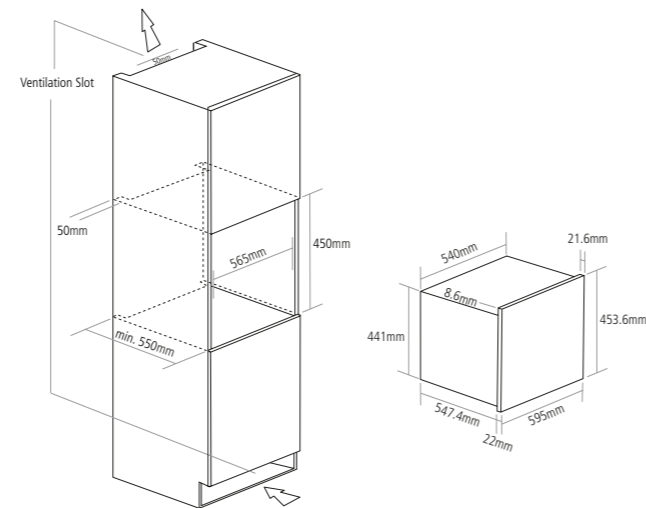

CM123 / CM123BK

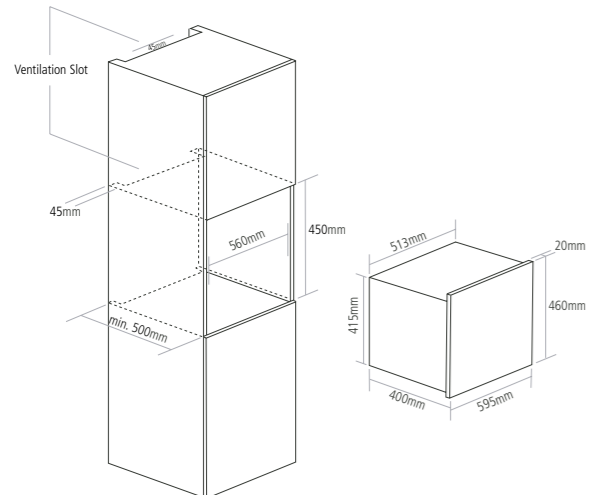

CM130

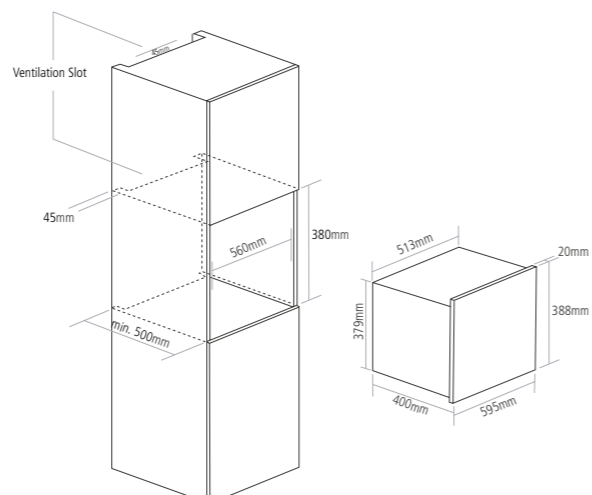

We recommend that when installing a stack or quad of products, a pair of our installation brackets [OVEN/BRACKETS2] are purchased to support the upper product ensuring a seamless fit for each appliance when one is on top of the other.

MICROWAVES

CM120

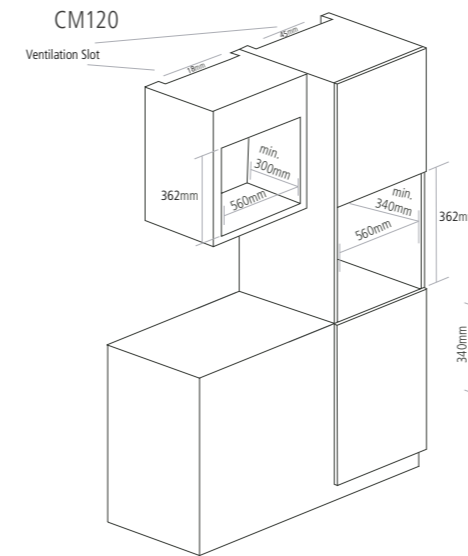

CM121BK

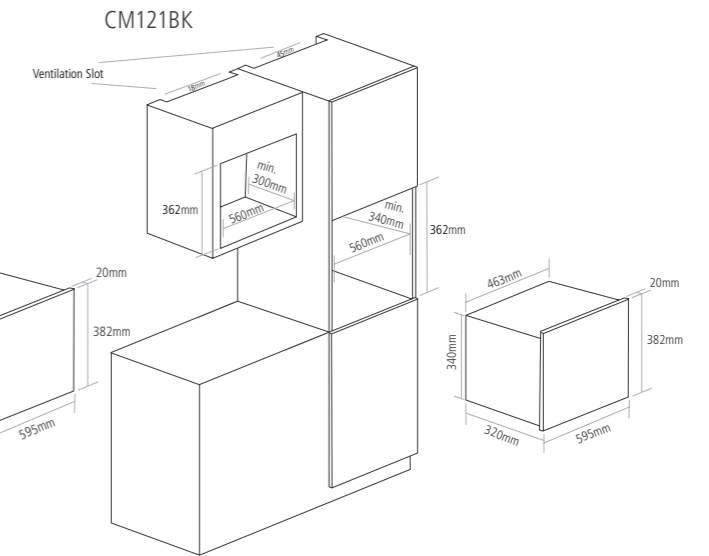

COFFEE MACHINES

CM465

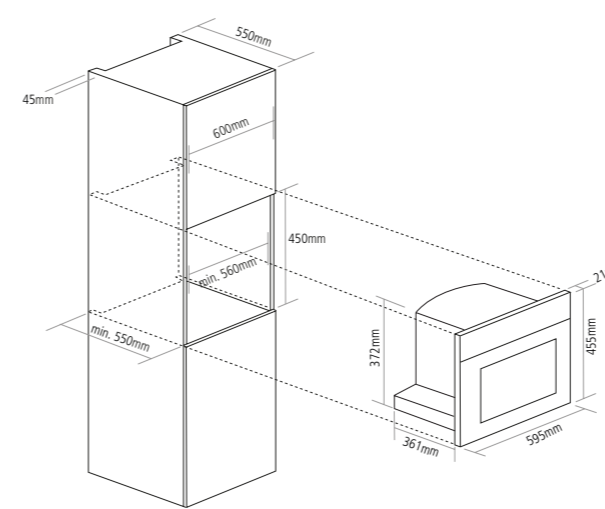

WARMING DRAWERS

WD290

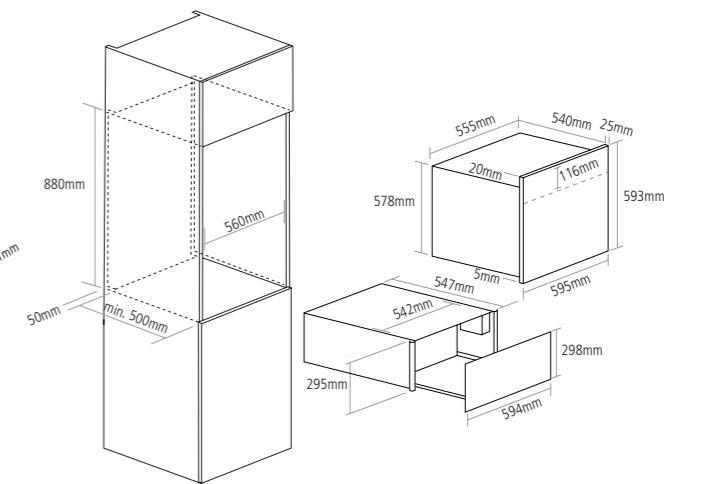

WD140

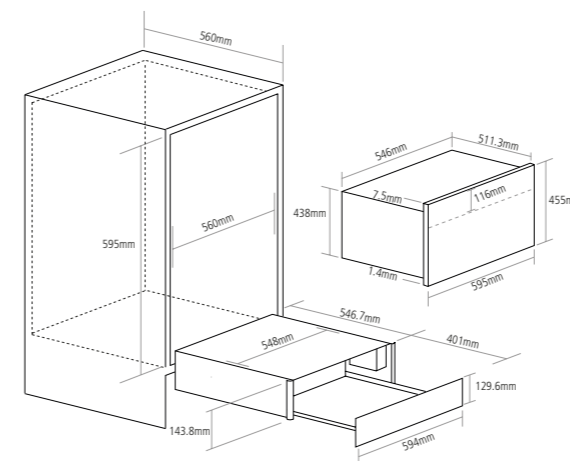

STORAGE DRAWER

SD140

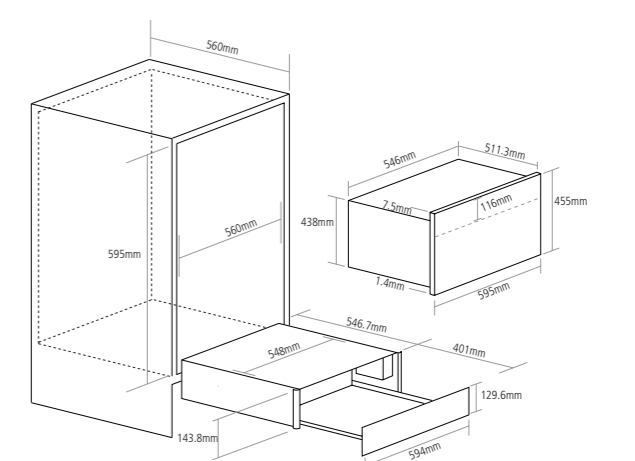

We recommend that when installing a stack or quad of products, a pair of our installation brackets [OVEN/BRACKETS2] are purchased to support the upper product ensuring a seamless fit for each appliance when one is on top of the other.

INDUCTION HOBS

C990i

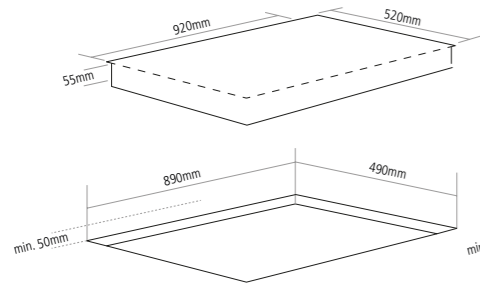

C876i

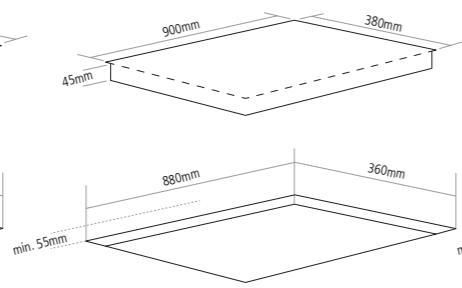

C901i

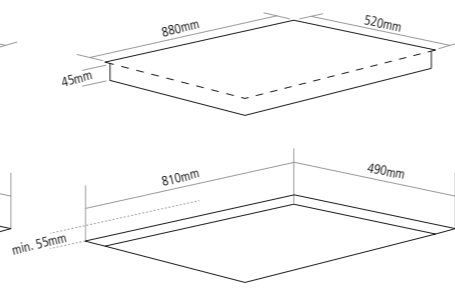

C897i

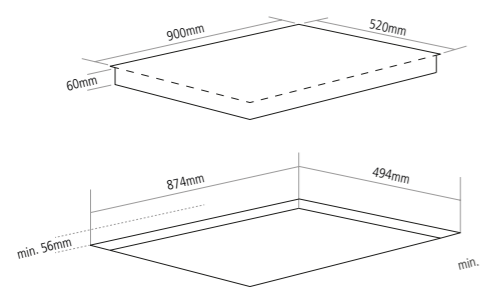

C858i

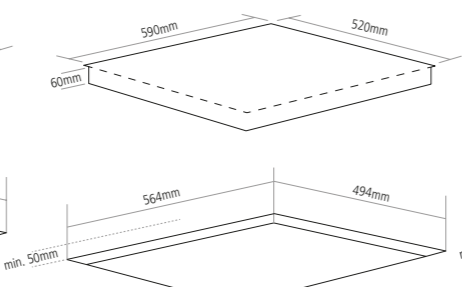

C8641i / C8641iGM

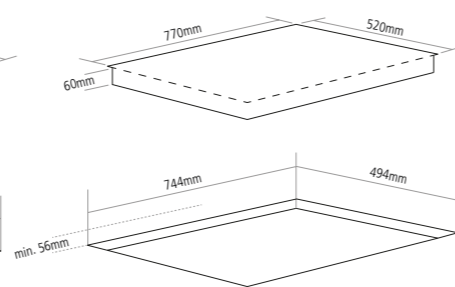

C8400i

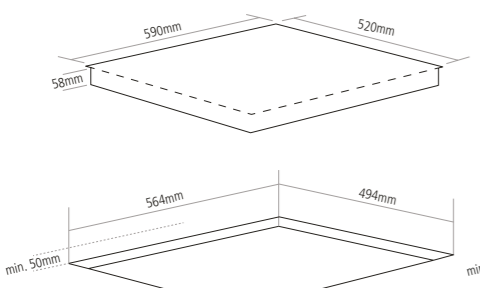

C847i

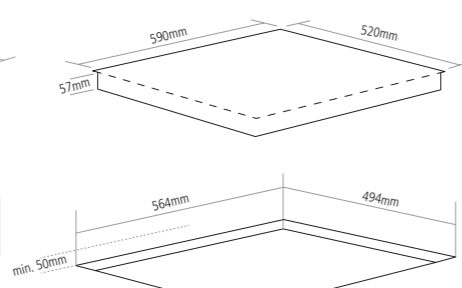

C845i

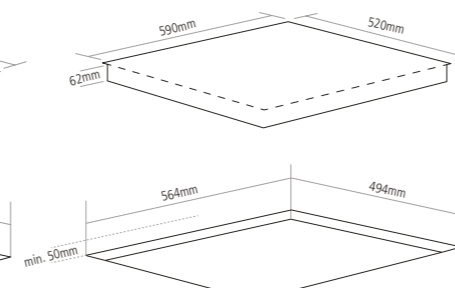

C841i

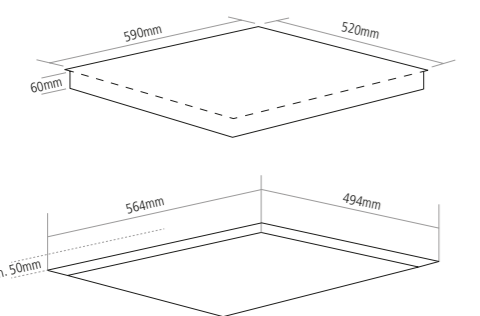

ELECTRIC HOBS

C8301C

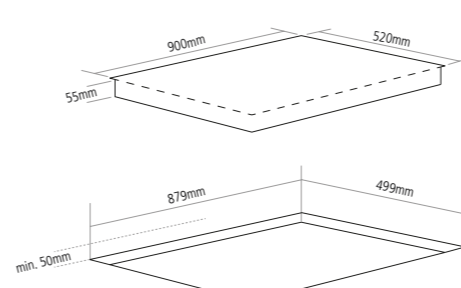

C8241C

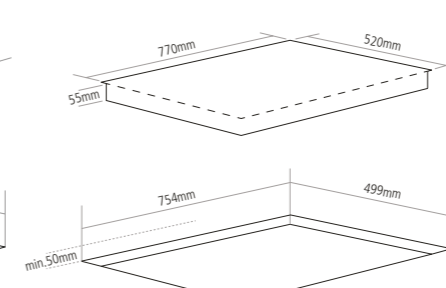

C816C / C809C

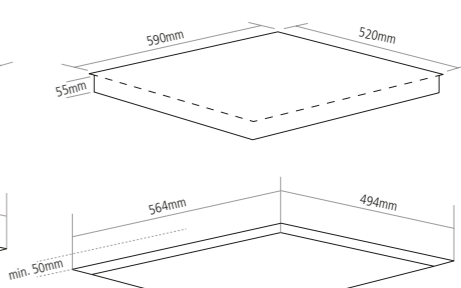

GAS HOBS

C7591G

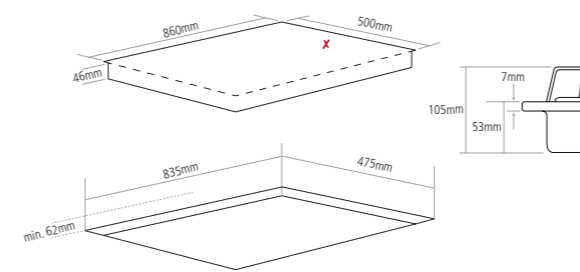

C7571G

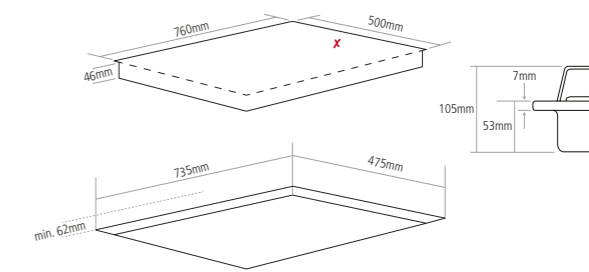

C7561G

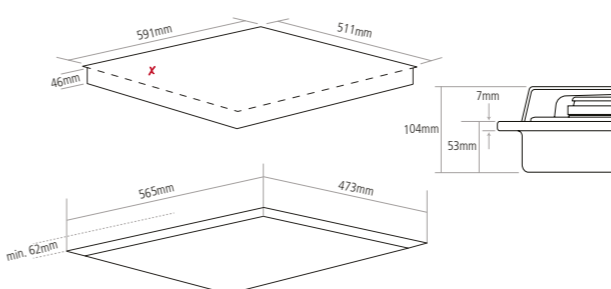

C7011G.....

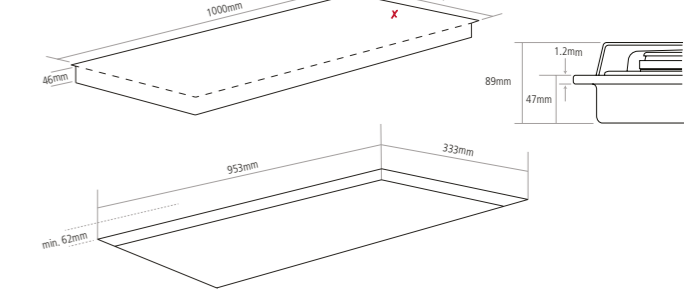

C7091G

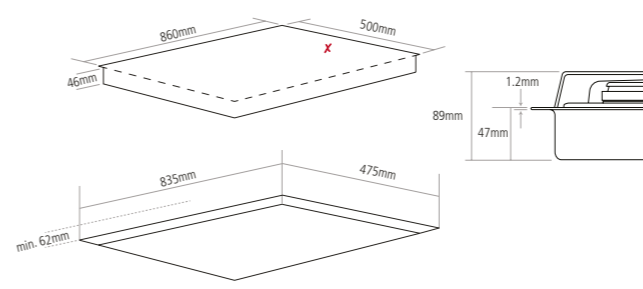

C7071G

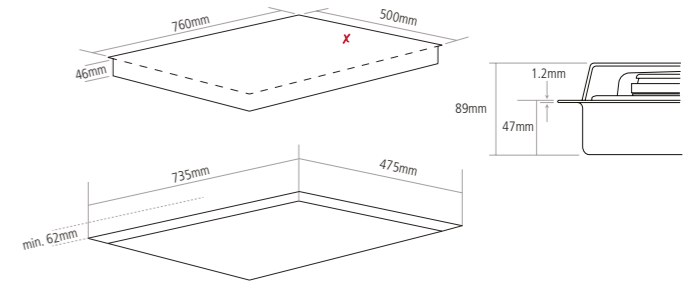

C7061G

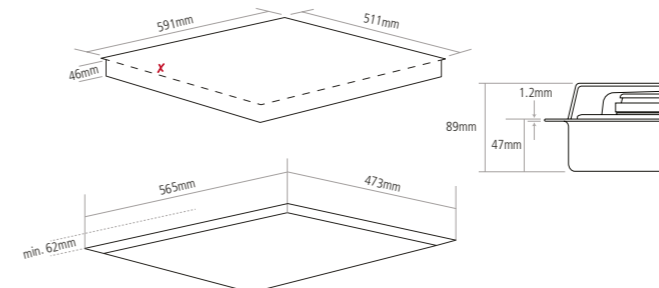

C4091G

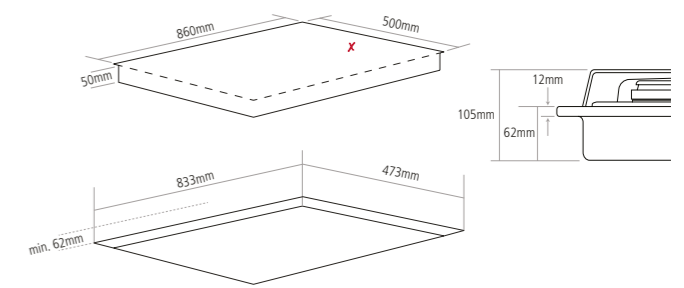

GAS HOBS

C4071G

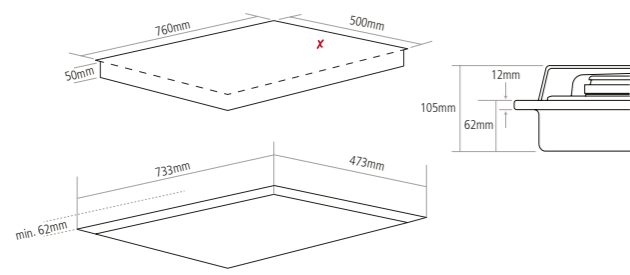

C4061G

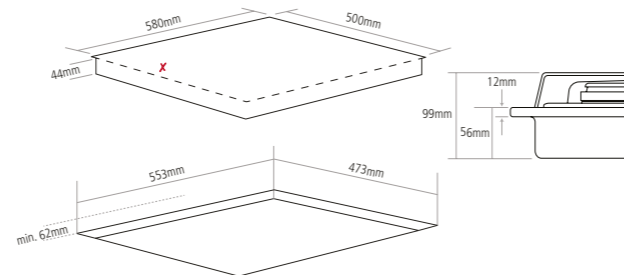

GAS HOBS

C887G

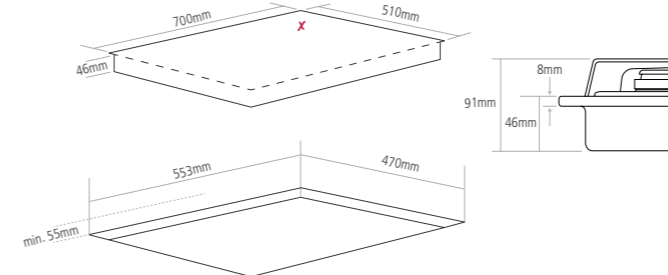

C886G

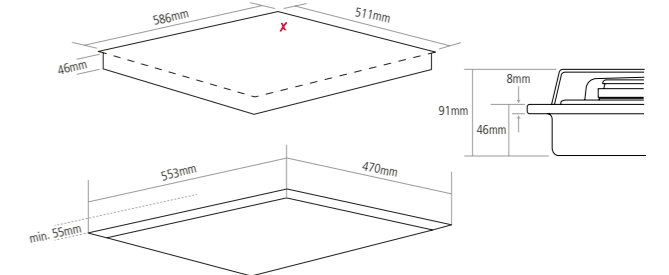

C789G

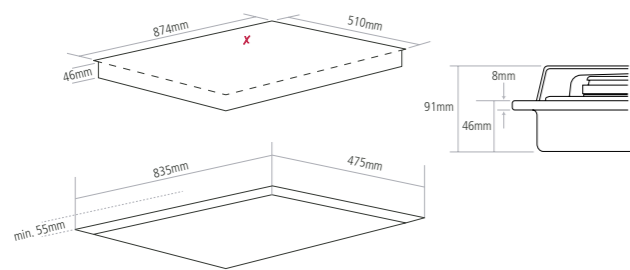

C787G

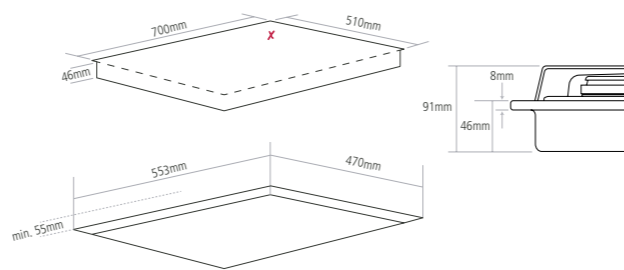

C775G

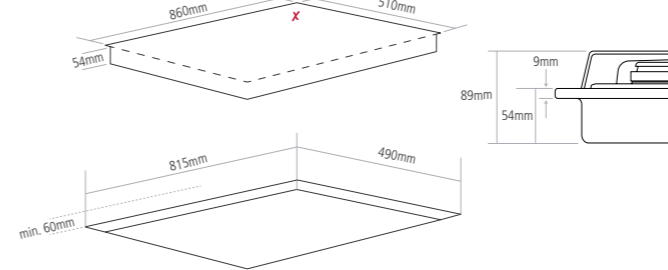

C768G

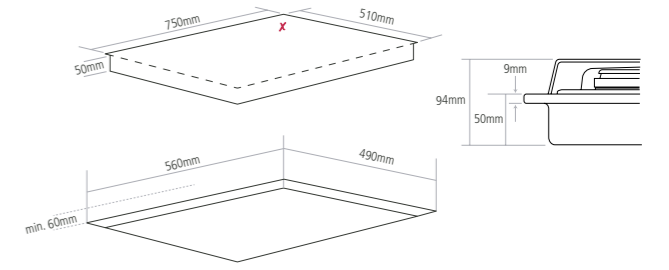

C786G

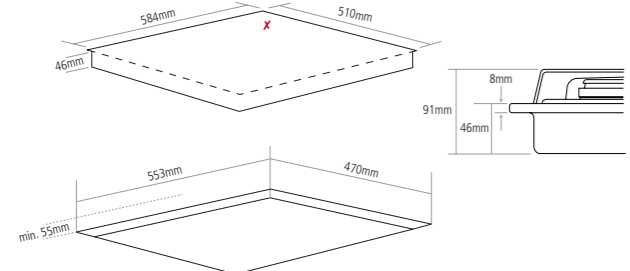

C944G

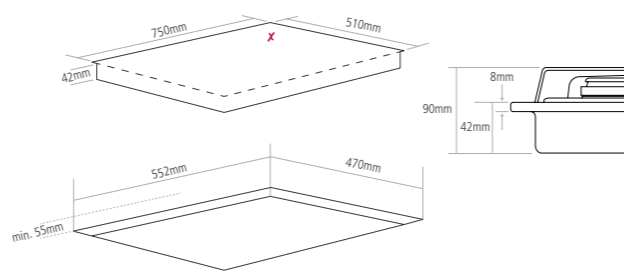

C750G

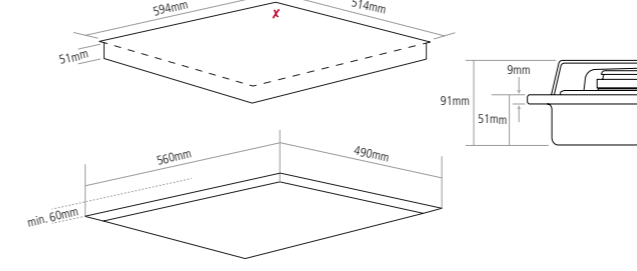

C706G

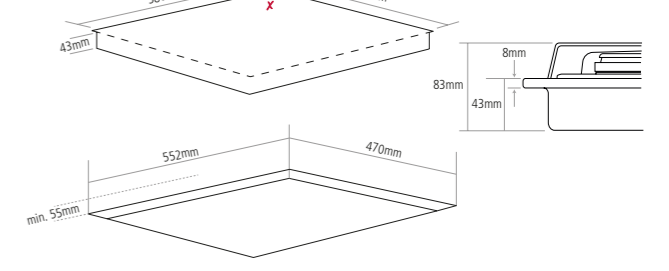

GAS CONNECTION

MODULAR HOBS

C744G

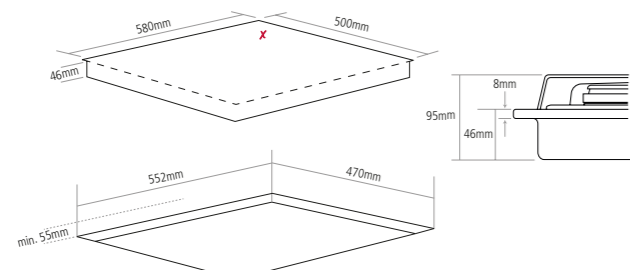

C889G

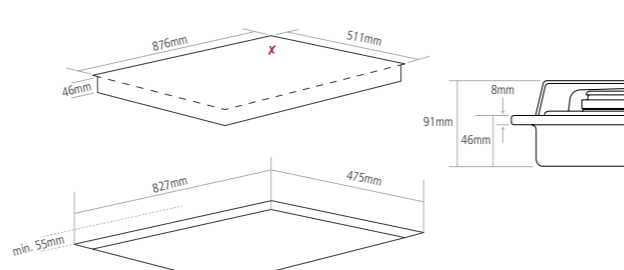

C997i

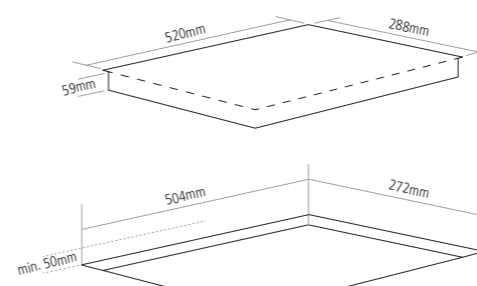

C894C

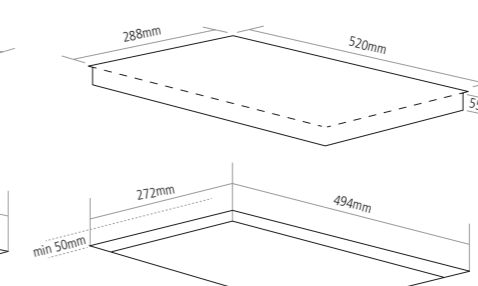

C890G

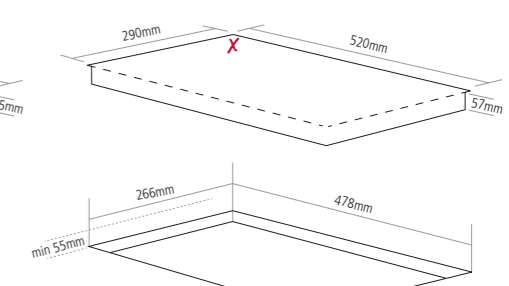

GAS CONNECTION

If installed without a gap in between, cut-out width = [no. of hobs - 1] x 288mm + 268mm



INDUCTION DOWNDRAFT HOB

DD820BK

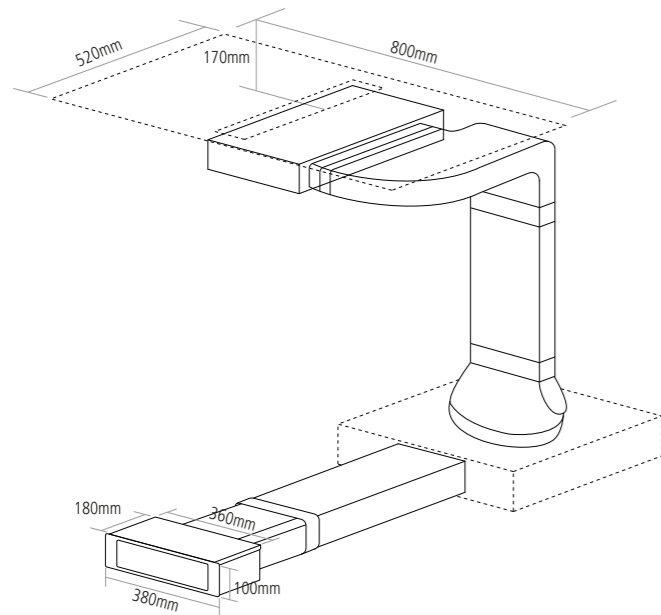

Inset cut-out 750 x 500mm. Refer to manual for further information. Shown with recirculation ducting KIT/961W [sold separately].

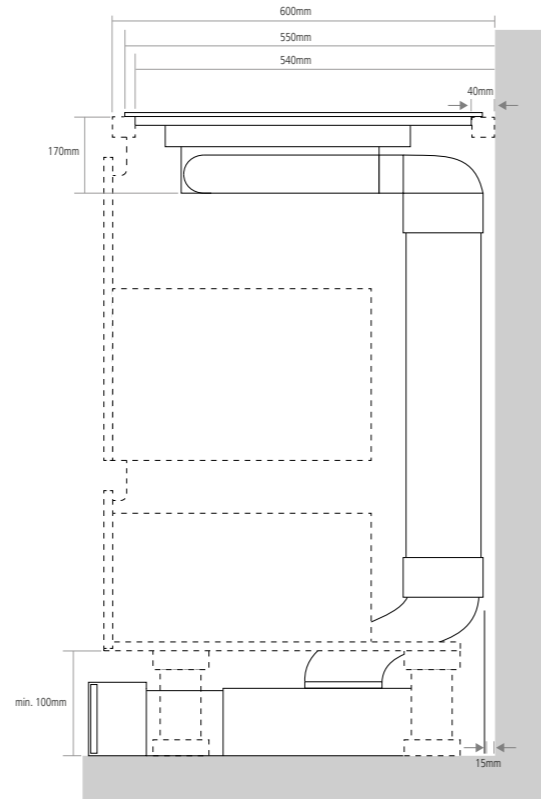

Shown with recirculation ducting KIT/961W [sold separately].

INDUCTION DOWNDRAFT HOB

DD810BK

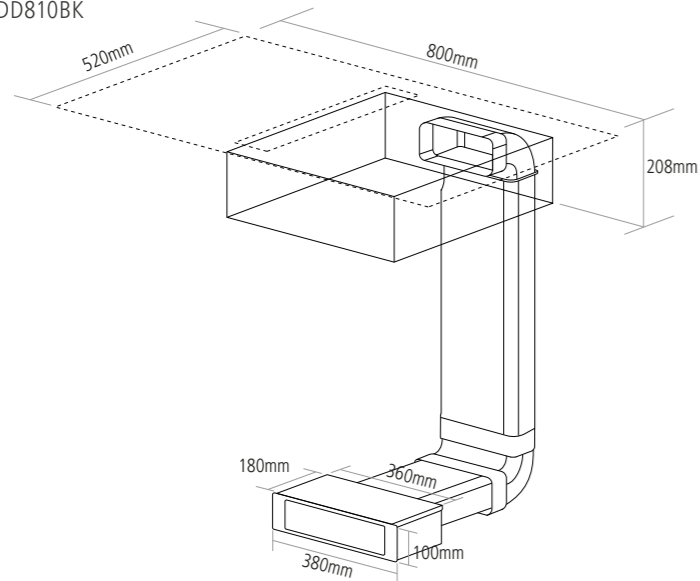

*Inset cut-out 750 x 500mm. Refer to manual for further information. Shown with recirculation ducting kit KIT/960W [sold separately].

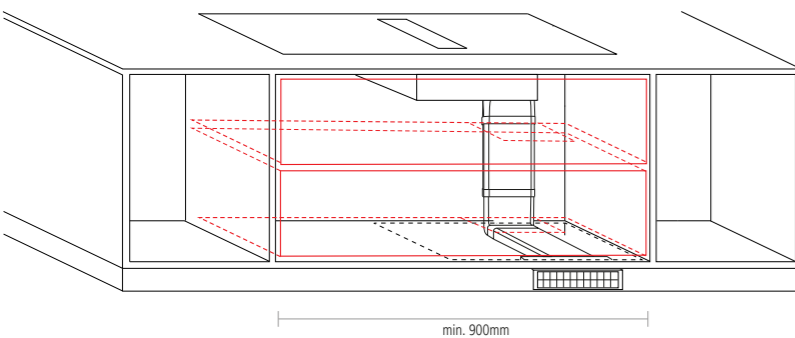

Shown with recirculation ducting kit KIT/960W [sold separately].

Shown with recirculation ducting kit KIT/960W [sold separately].

INDUCTION DOWNDRAFT HOB

DD780BK

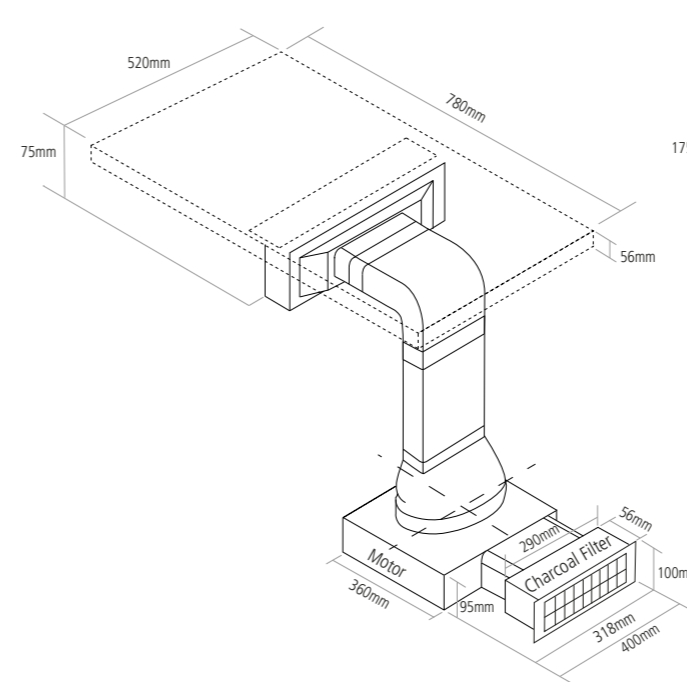

Shown with recirculation ducting kit [supplied with downdraft].

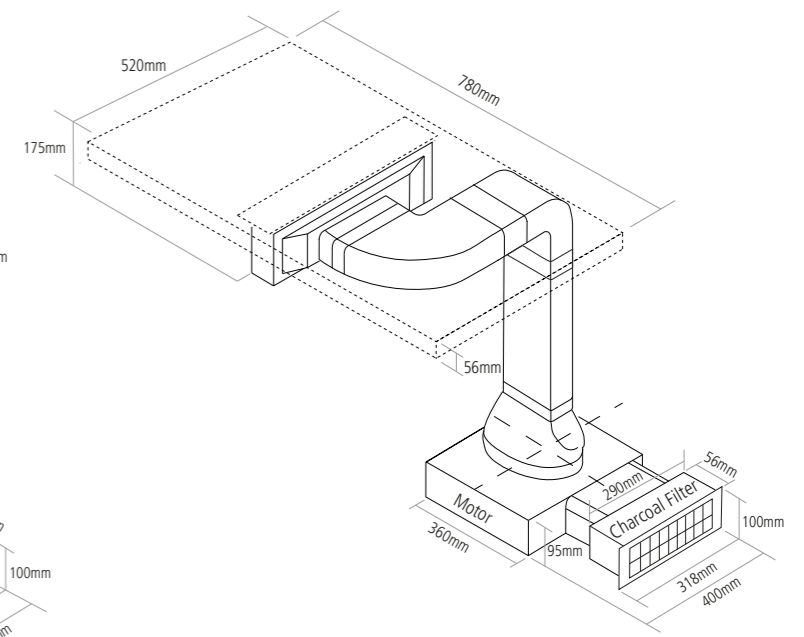

*Worktop cut-out 750 x 490mm. Refer to manual for further information. Minimum base unit 1000mm. Shown with recirculation ducting kit [supplied with downdraft].

INSTALLATION

Example A

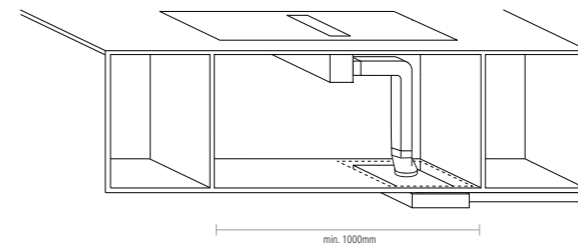

Shown with recirculation ducting kit [supplied with downdraft].

INSTALLATION

Example B

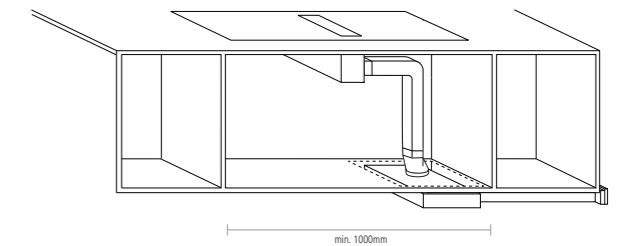

Shown with recirculation ducting kit [supplied with downdraft].

INSTALLATION MADE EASY

Minimum cabinet depth depends on orientation, hob type and worktop material. Cabinet base may need to be cut or routed to accommodate height of unit. If positioned behind a hob, minimum cabinet width for DD522BK/606BK extractors is 600mm, and for DD903/911/901 allow 900mm. If positioned alongside a hob, the cabinet may need to be reinforced to strengthen where the base has been modified.

The hood can be fitted right up to an electric hob [50mm gap required for gas hobs], but always ensure that the independent electronics box in the cupboard below is installed at least 650mm from the heat source.

The hood can be ducted from both sides enabling the downdraft to be positioned behind a hob and under-counter oven.

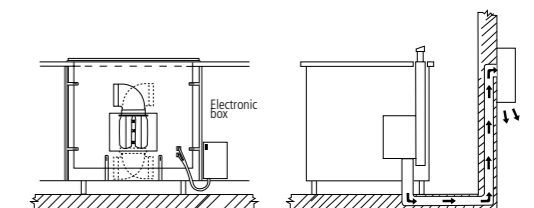

INDUCTION DOWNDRAFT HOB

DD610BK

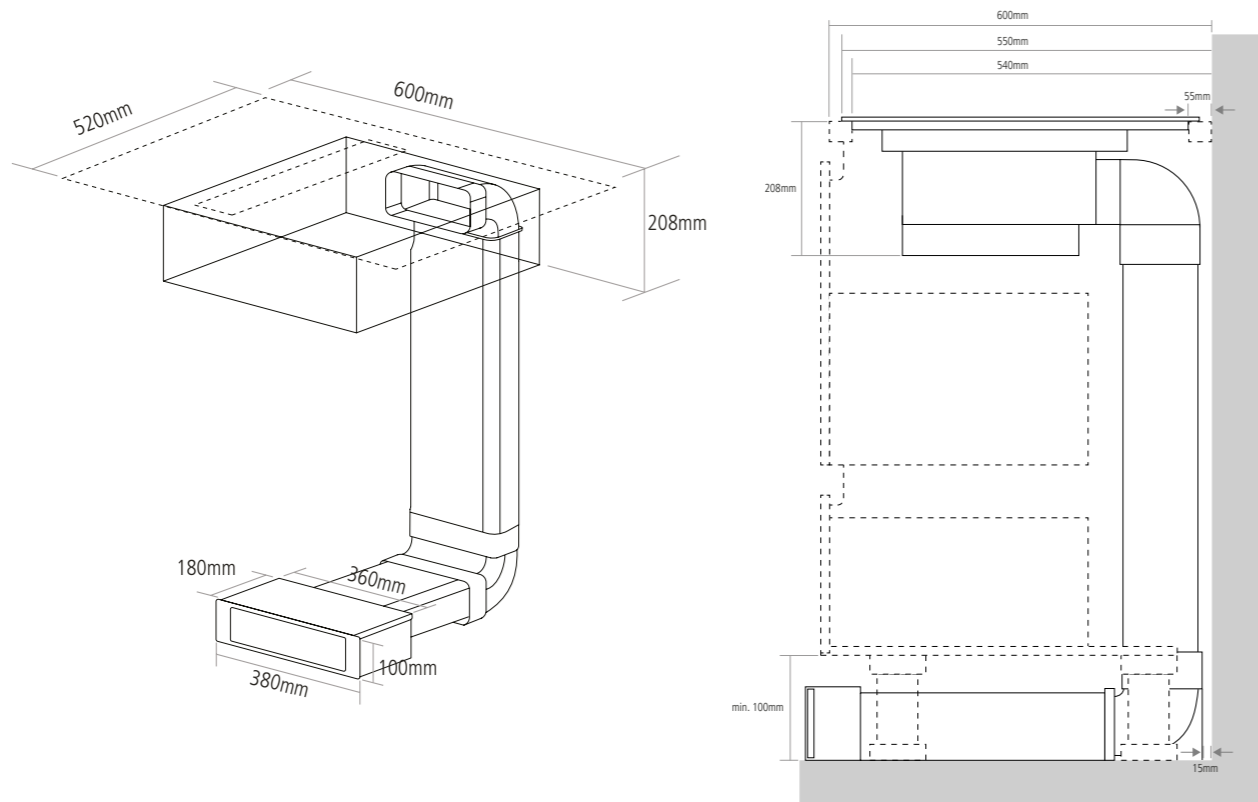

*Inset cut-out 560 x 490mm. Refer to manual for further information.
Shown with recirculation ducting kit KIT/960W [sold separately]

PLASMA FILTERS

GUC1212

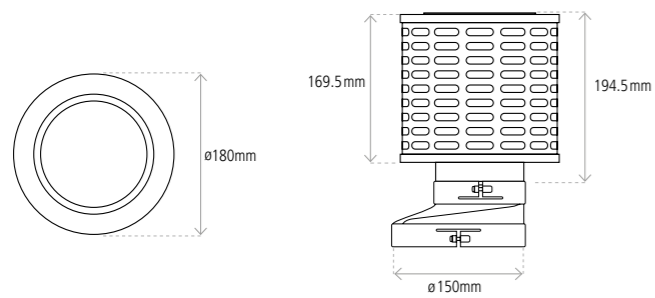

GUC1214

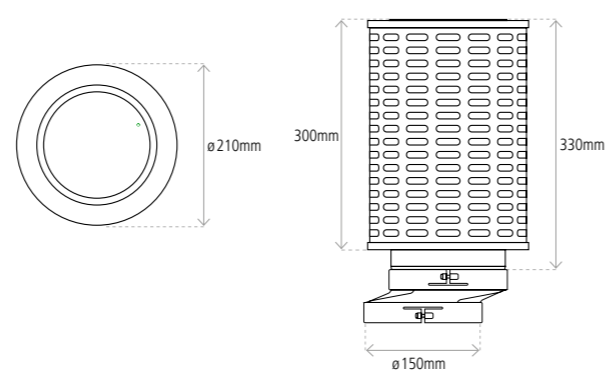

GUC1314

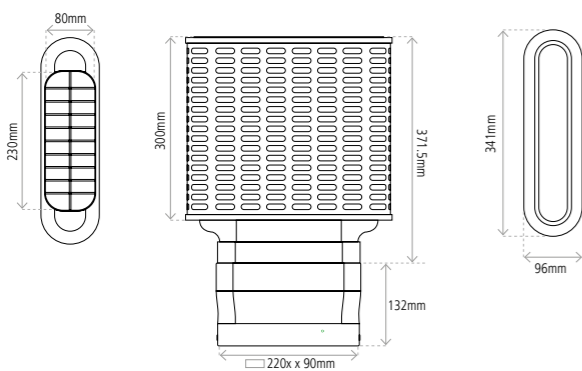

DOWNDRAFT EXTRACTORS

DD925CO

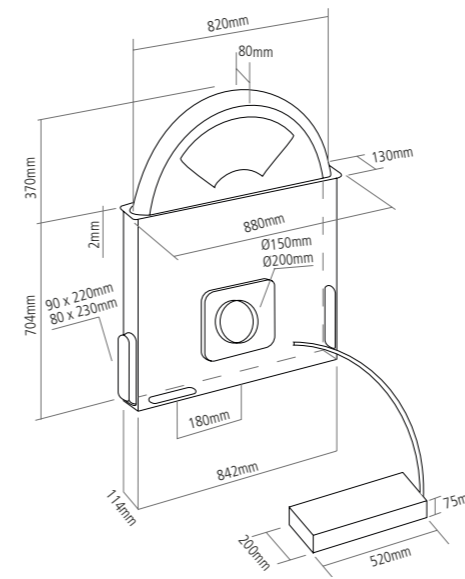

DD903BK

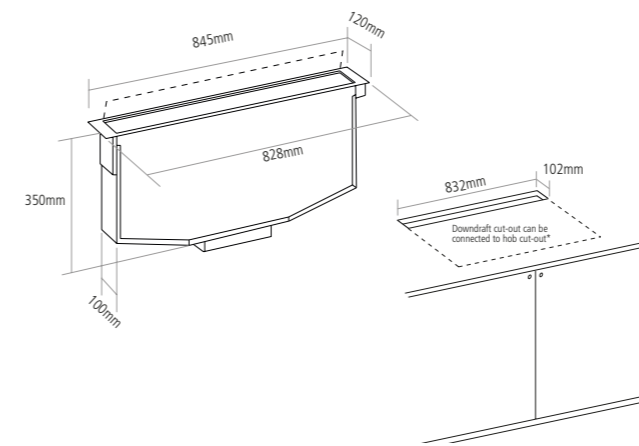

*For electric hobs only. A 50mm gap is required for gas hobs.

DD523BK

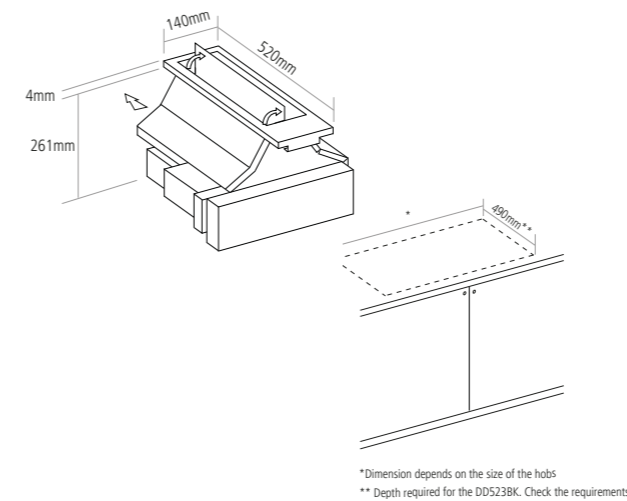

*Dimensions depends on the size of the hobs

** Depth required for the DD523BK. Check the requirements

DD912BK

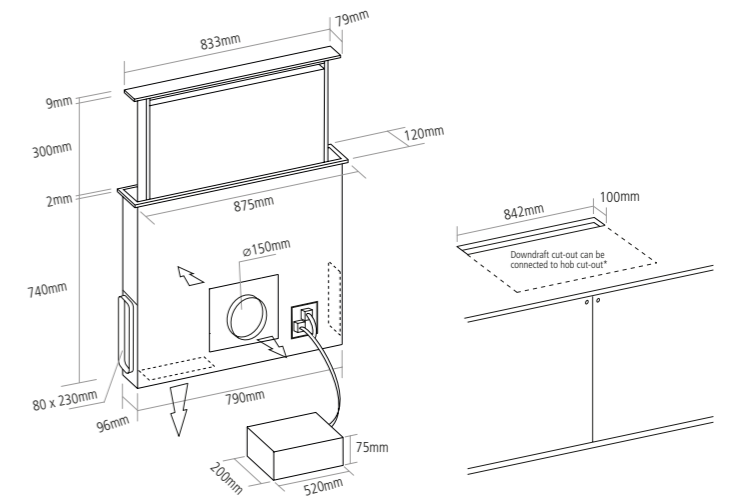

*For electric hobs only. A 50mm gap is required for gas hobs.

DD901BK

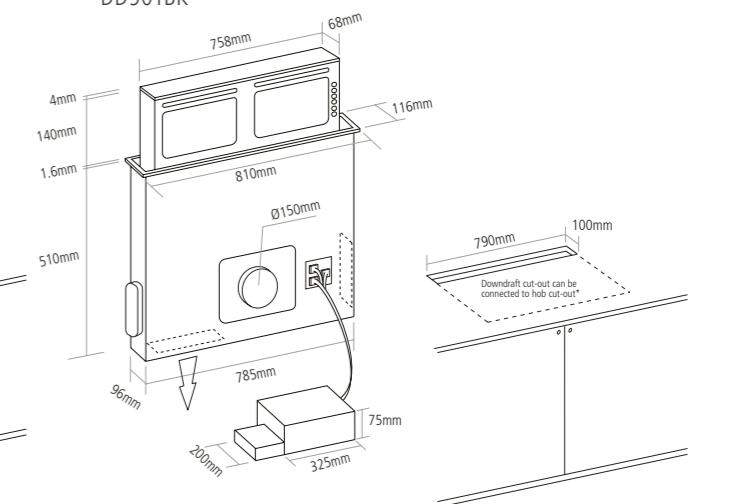

*For electric hobs only. A 50mm gap is required for gas hobs.

DD522BK

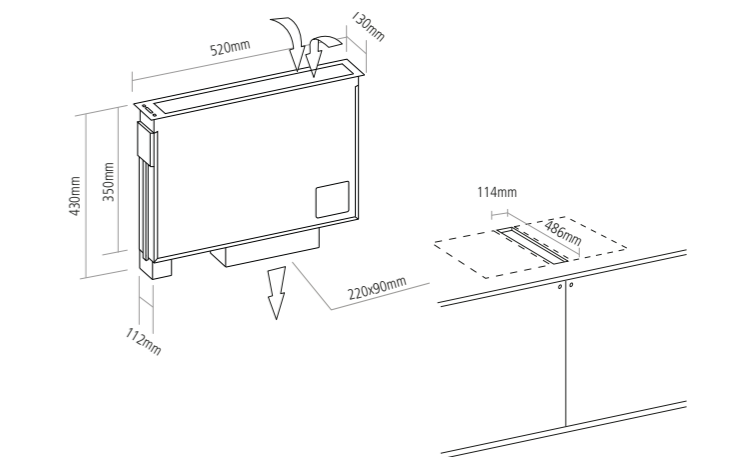

*For electric hobs only. A 50mm gap is required for gas hobs.

DOWNDRAFT EXTRACTORS

DD606BK

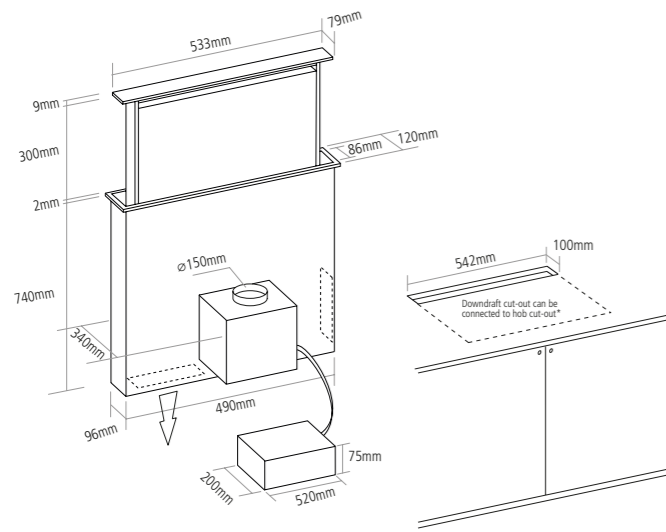

CE930

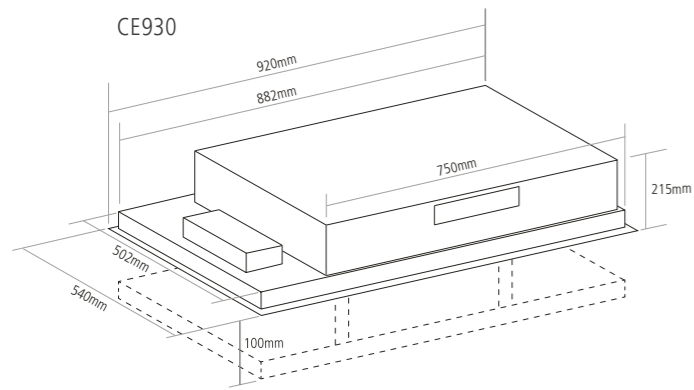

CE921WH

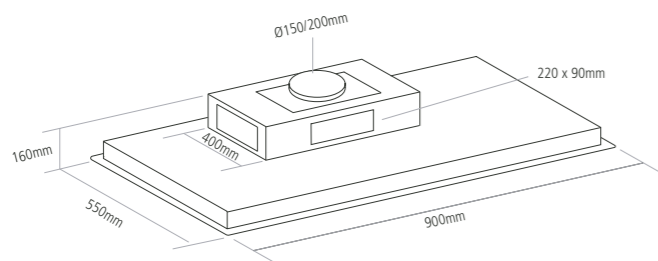

For installation into the ceiling a niche of 815mm x 515mm is required, with a minimum height of 170mm.

CEILING HOODS

COR541SL

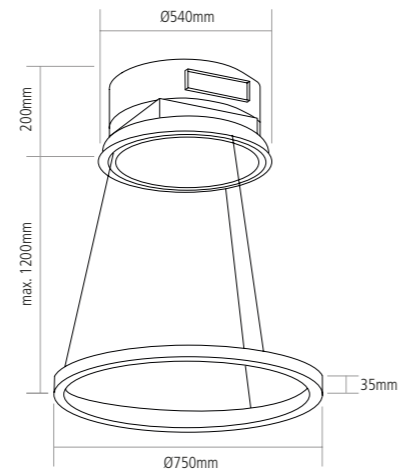

For installation create a false ceiling with a round niche of 510mm, with a minimum height of 220mm.

CE1122SS / CE1122WH

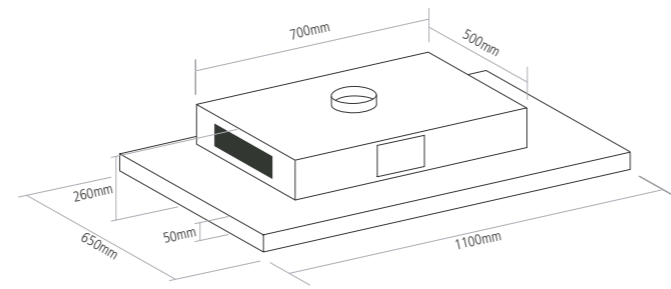

Minimum build in depth 215mm

CE903

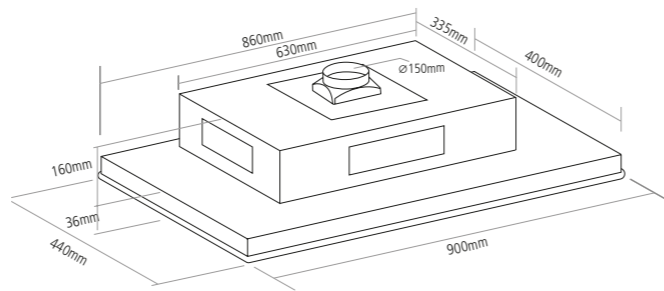

EXTRACTION MOTORS

DDMEXT11

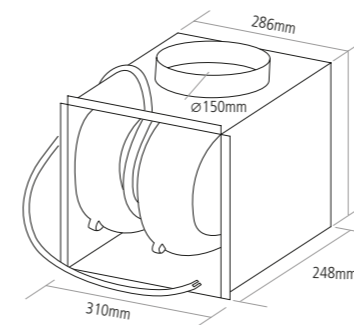

DDMEXT28

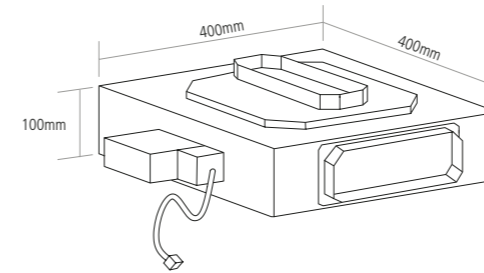

DDMEXT21

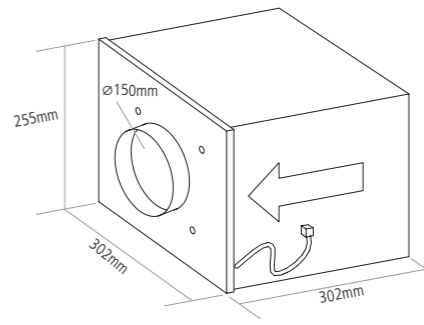

DDMEXT31

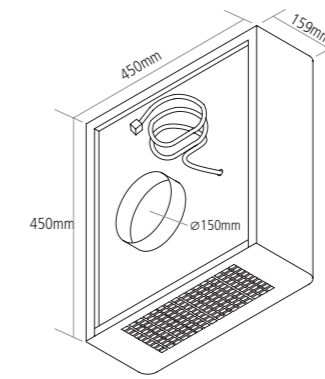

DDMEXT25

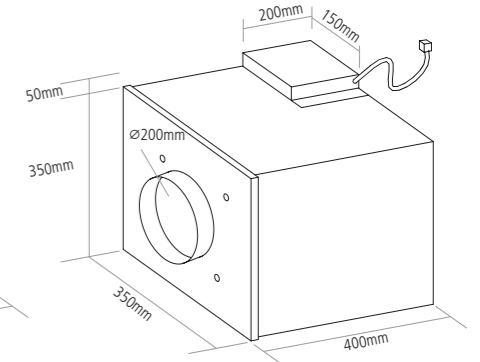

DDMEXT40

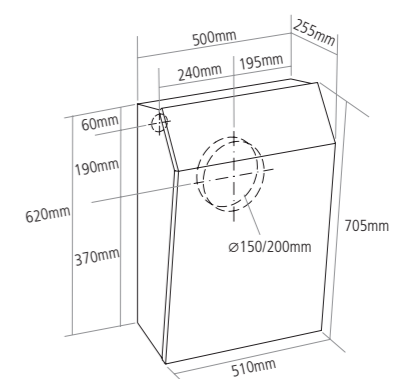

ISLAND HOODS

Vela

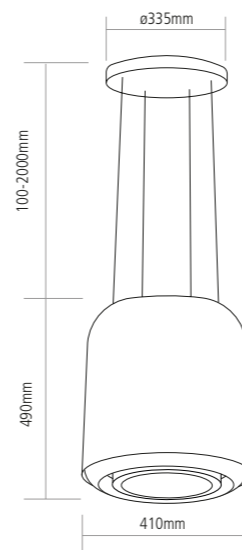

Ceramica

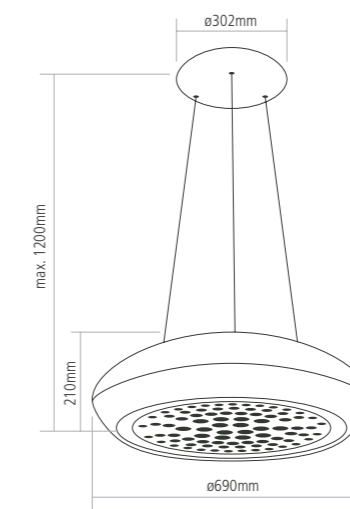

Oi363

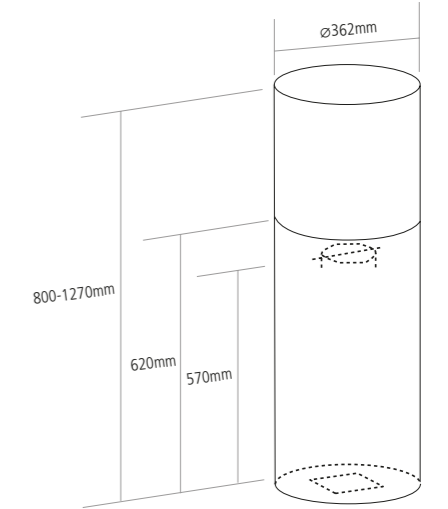

ISLAND HOODS

Tela

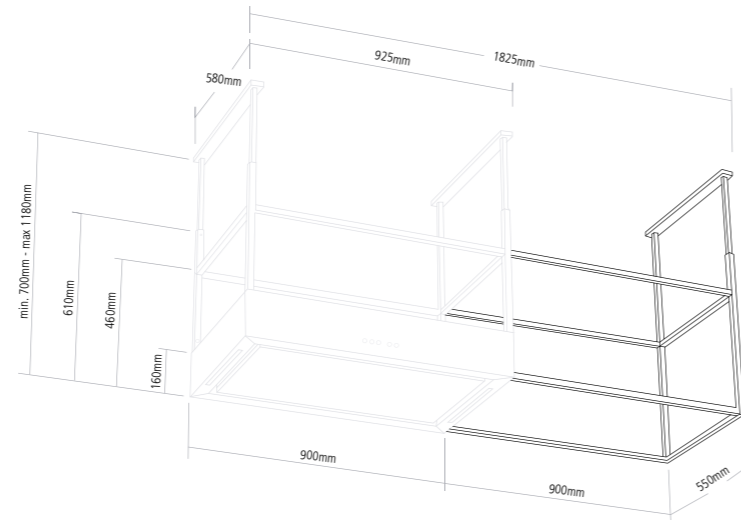
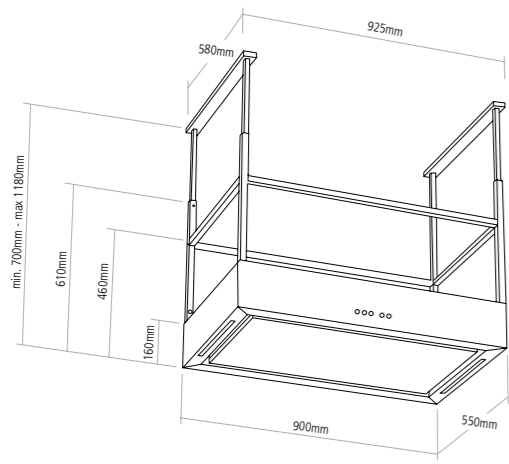

WALL CHIMNEY HOODS

CGi920/RED

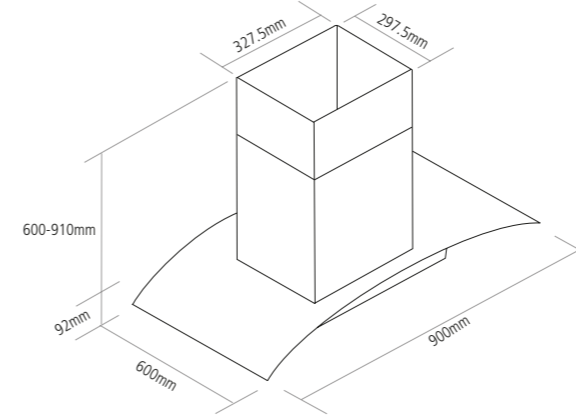

Note: Suitable to be installed in a standard room height of 2.3m

Zella

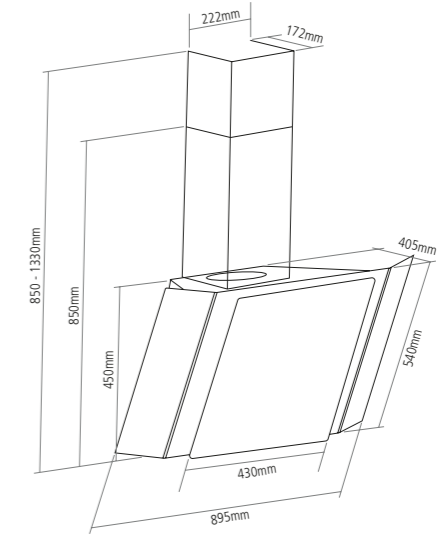

BXi911

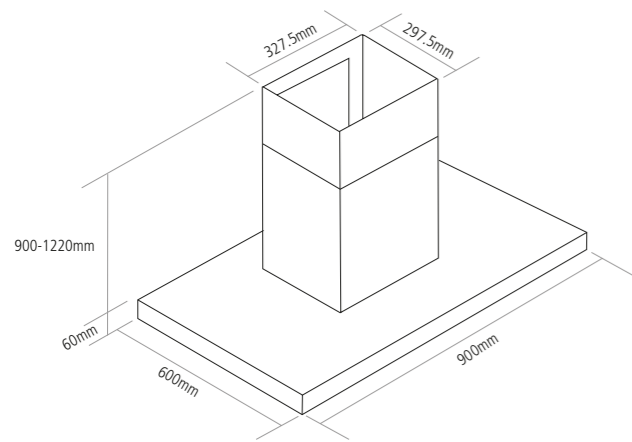

Zi922

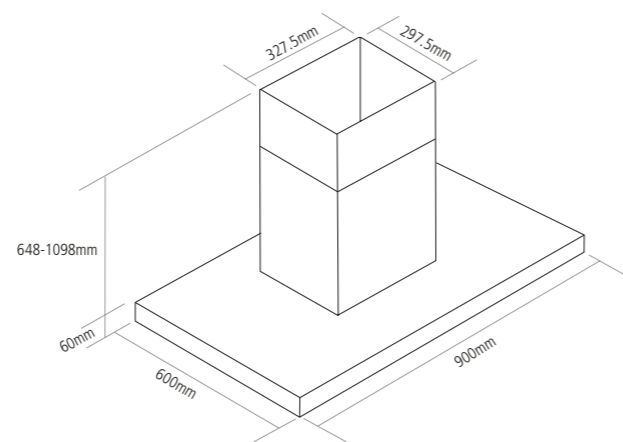

Atara

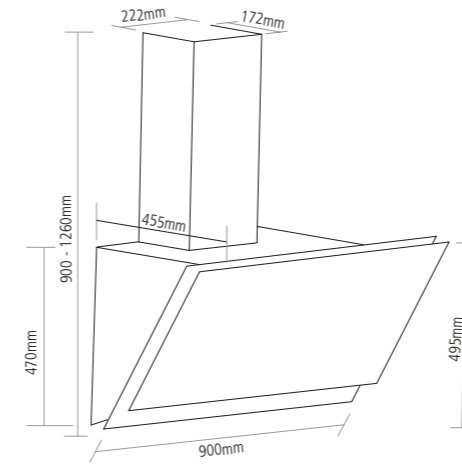

Zodiac

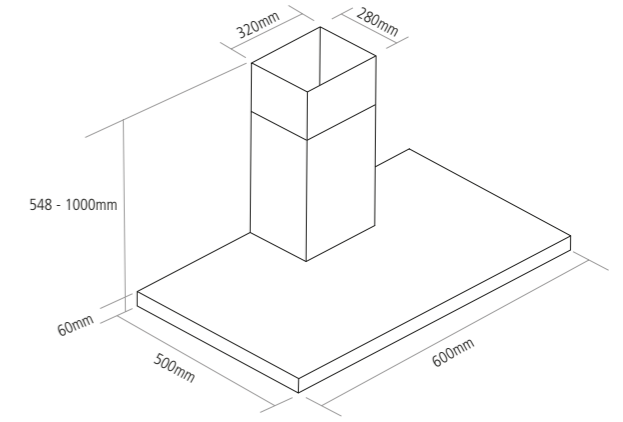

WALL CHIMNEY HOODS

CGi921

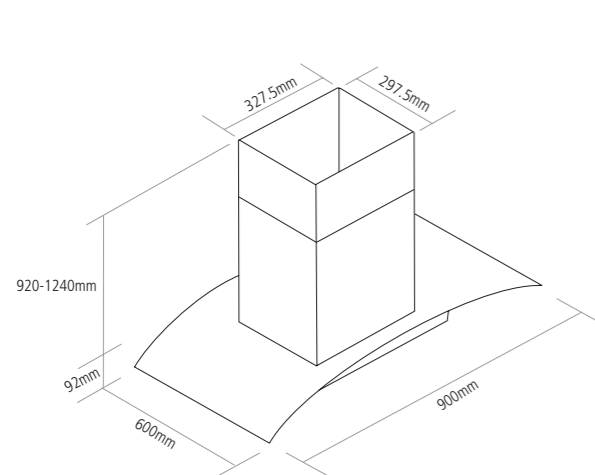

Pyra

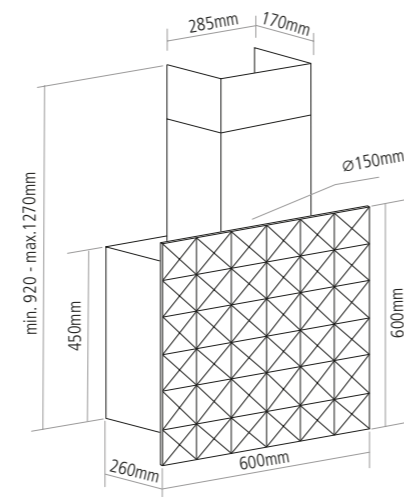

Omnis

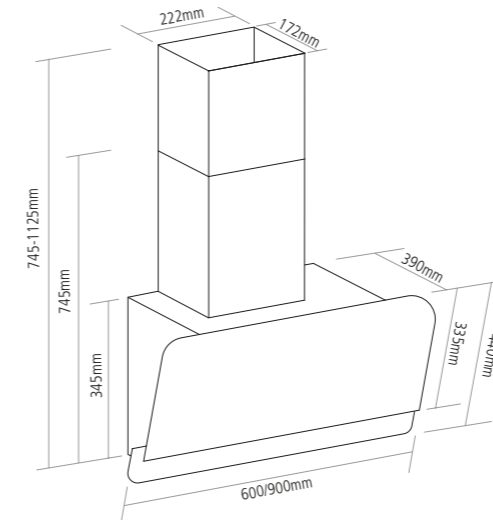

Spirit

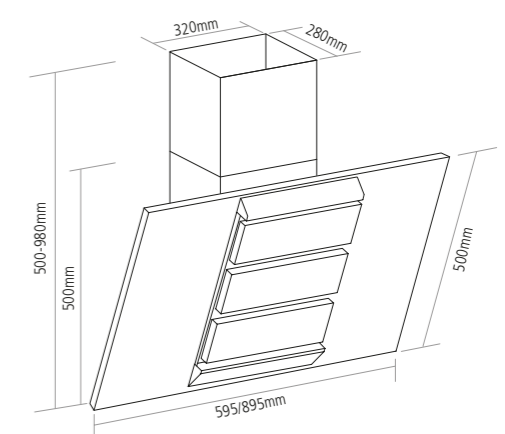

CLASSIC HOODS

FGC920 / FGC720 / FGC621

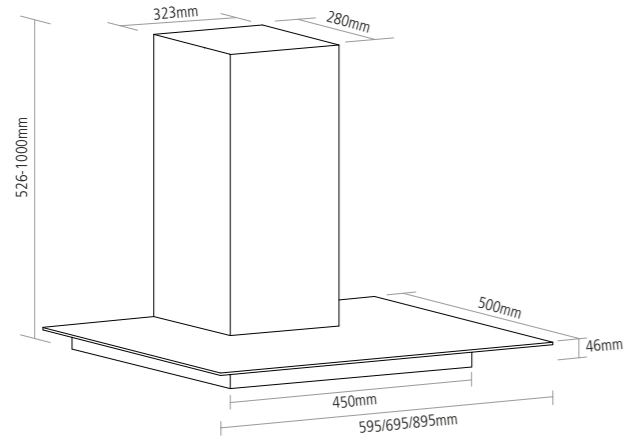

CGC911SS / CGC911BK

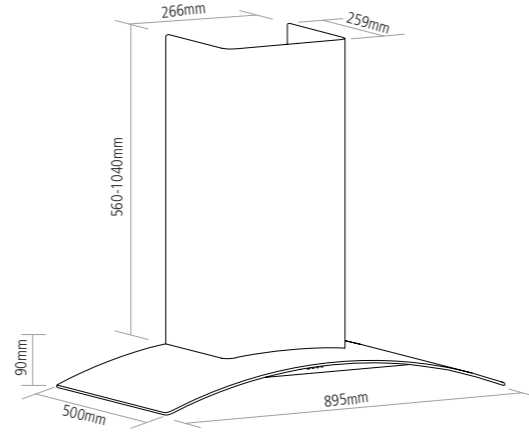

CGC711SS / CGC711BK

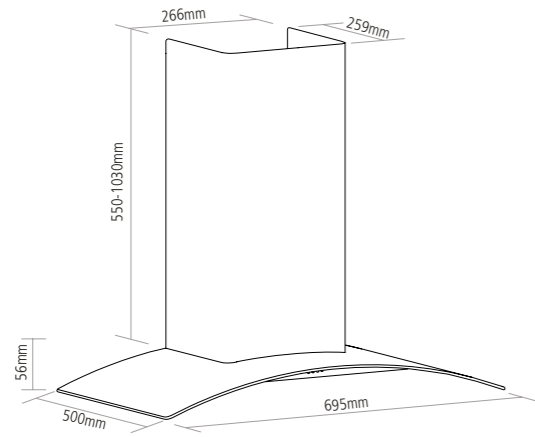

CGC611SS / CGC611BK

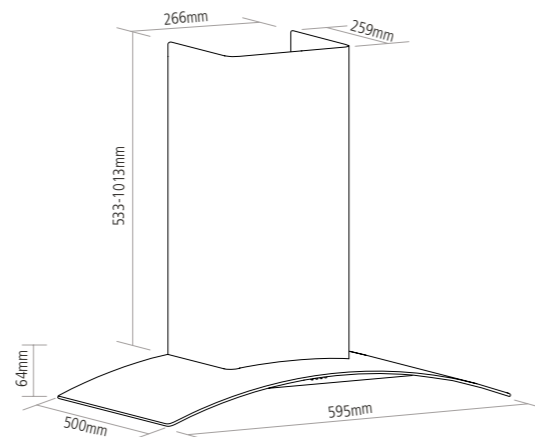

650mm space for electric hobs and 760mm space for gas hobs required from worktop to the mesh filter behind the centre glass panel. From the lowest point of the hood the distance required is 450mm for electric hobs and 550mm for gas hobs.

BXC911 / BXC611

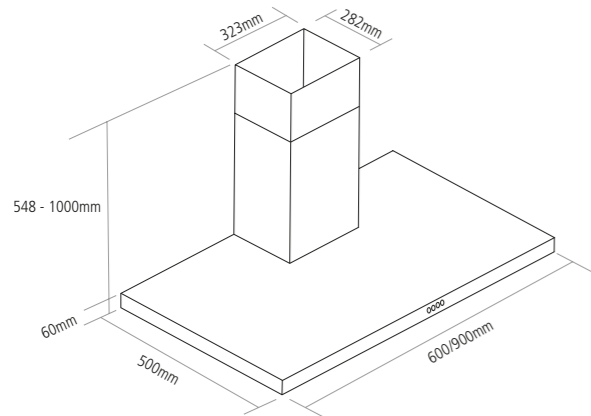

AH600BK

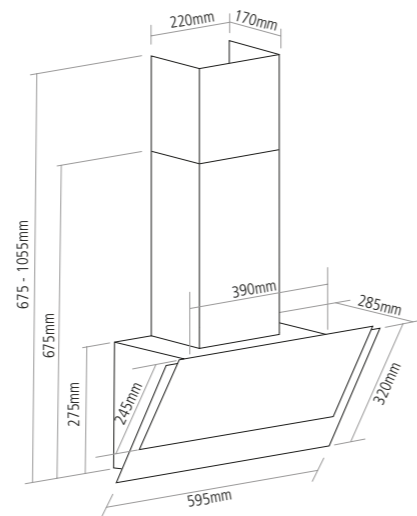

CLASSIC HOODS

CCH101

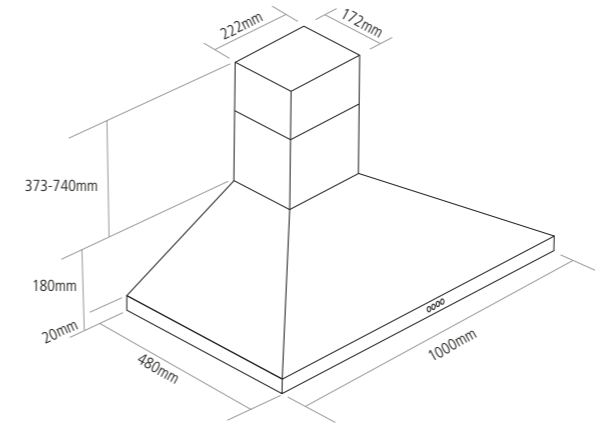

CCH901SS / CCH901BK

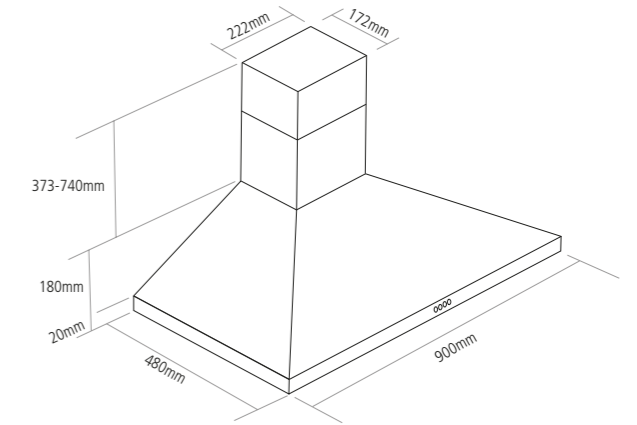

CCH701

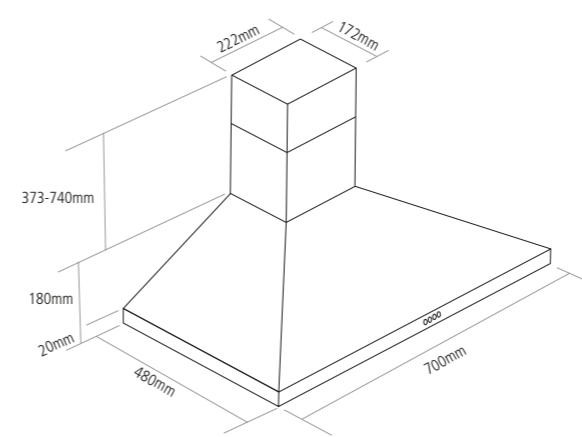

CCH601SS / CCH601BK

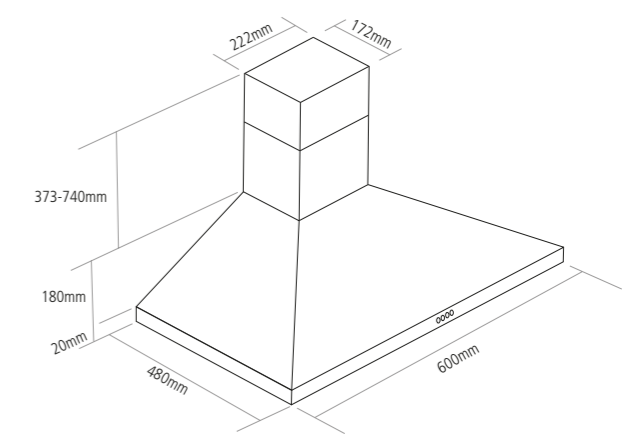

INTEGRATED HOOD

INCH

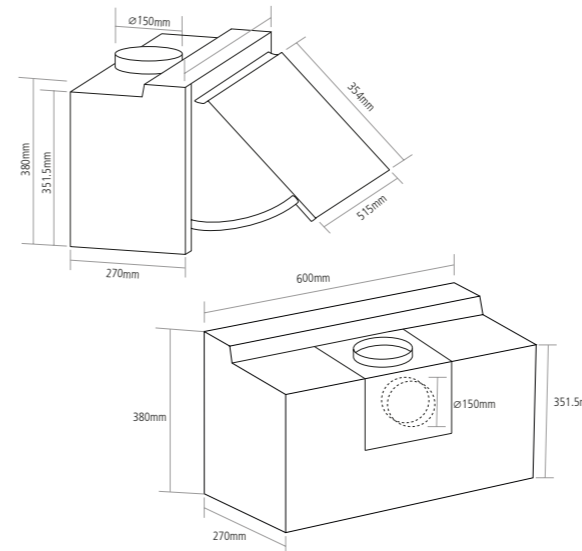

BUILT UNDER HOODS

ST854

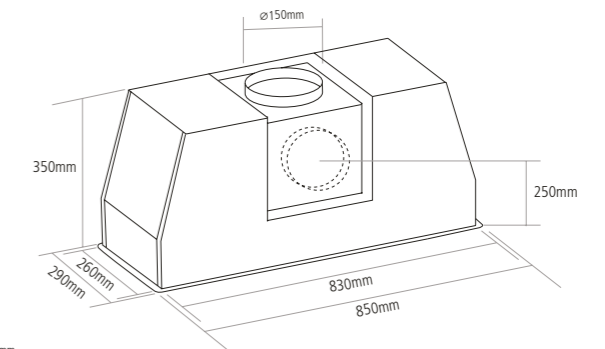

BUILT UNDER HOODS

ST524

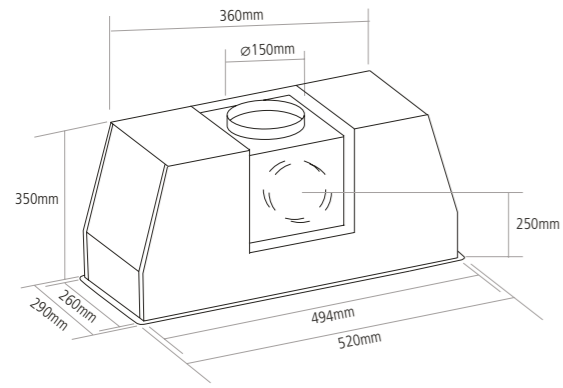

TBU851

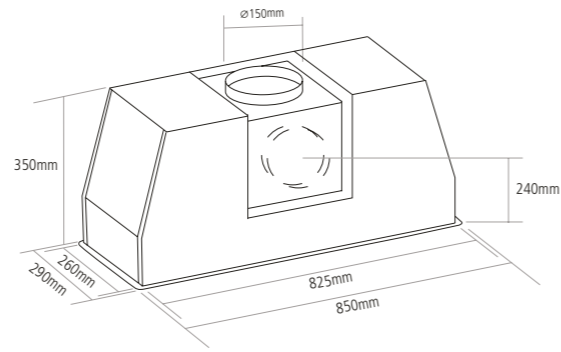

TBU521

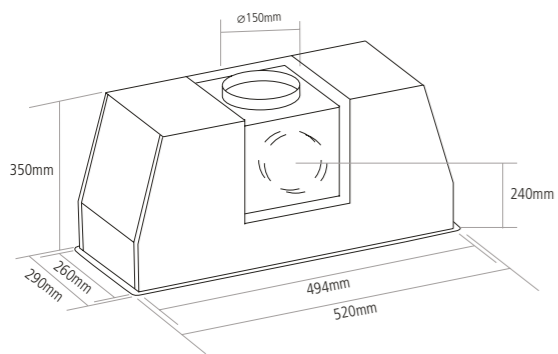

BU521

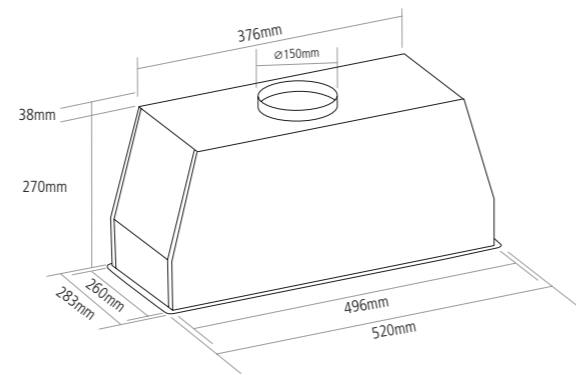

BU755BK

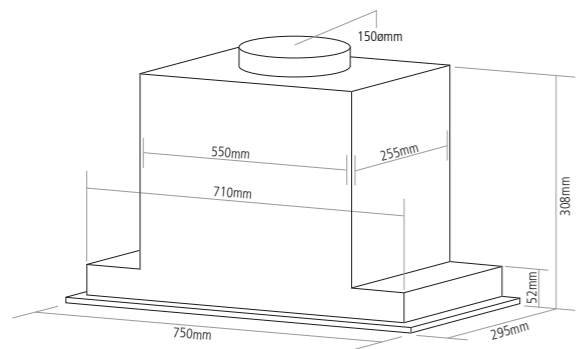

BU525BK

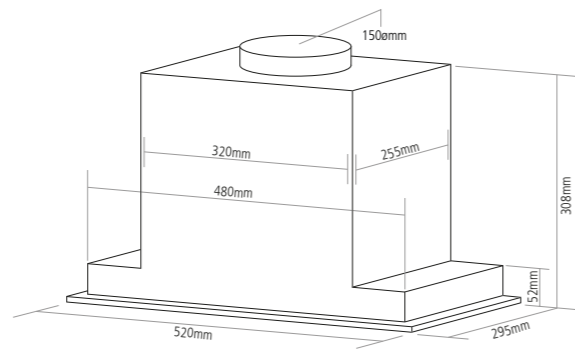

BUILT UNDER HOODS

TSCH601

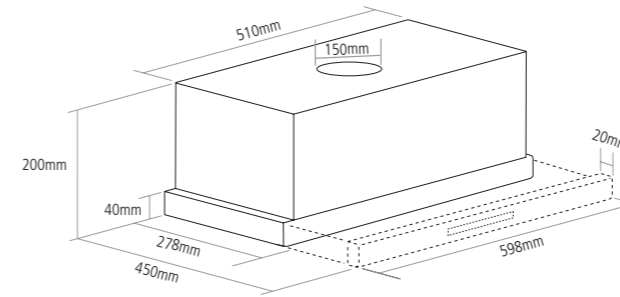

TSCH901

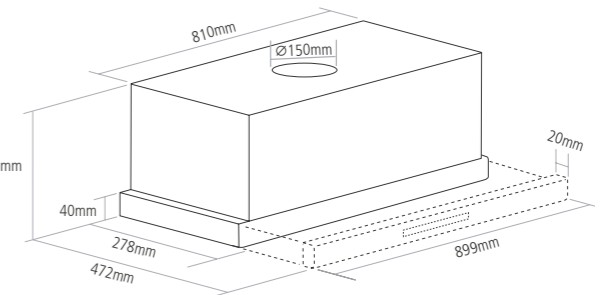

BUCH

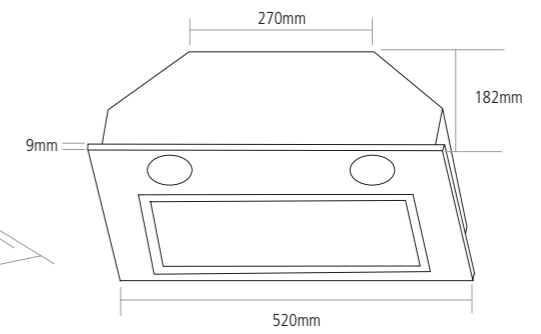
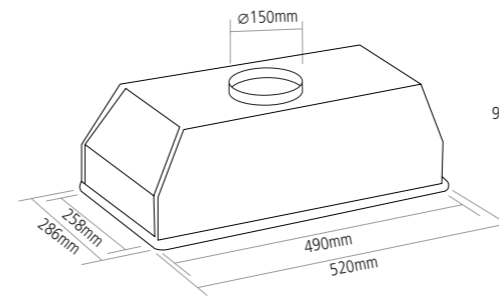

BUCH75

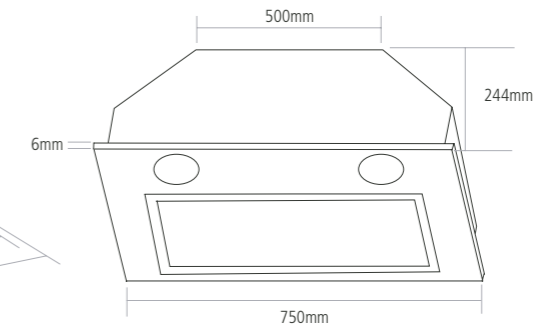
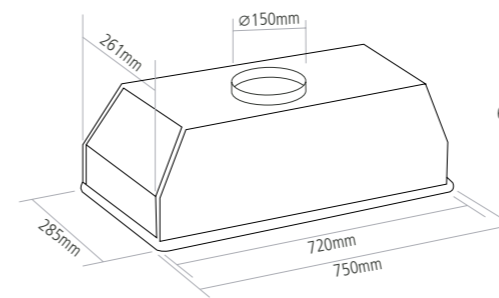

FSCHSS9

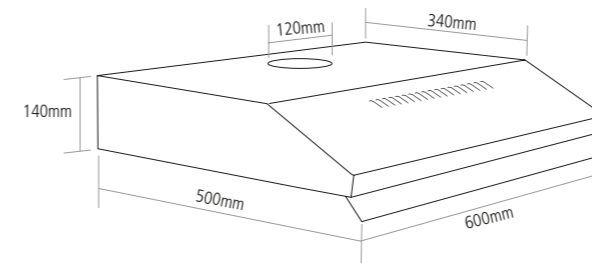



FRENCH DOOR FRIDGE FREEZER

CAFF43

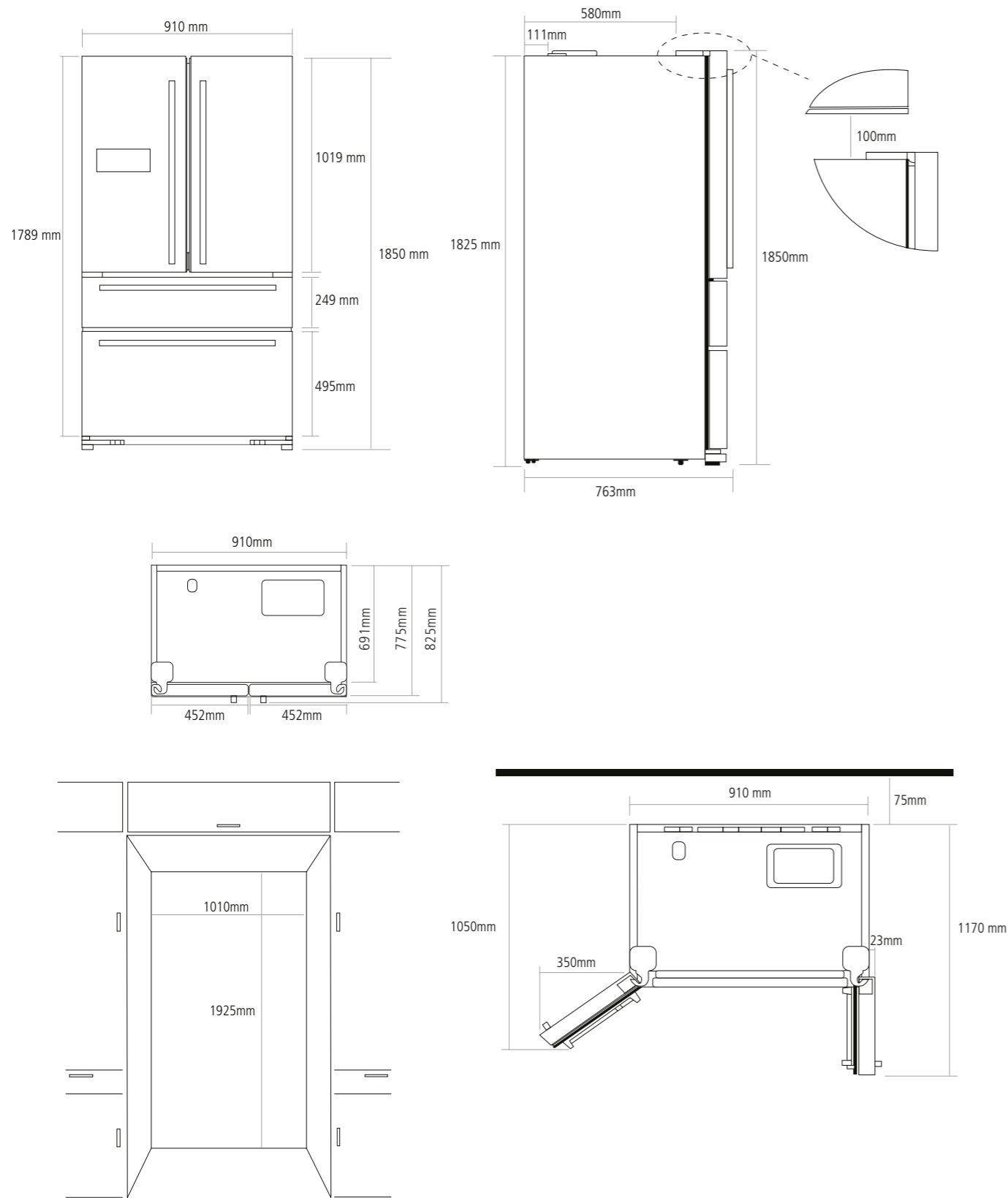

FREESTANDING REFRIGERATION

RFF732

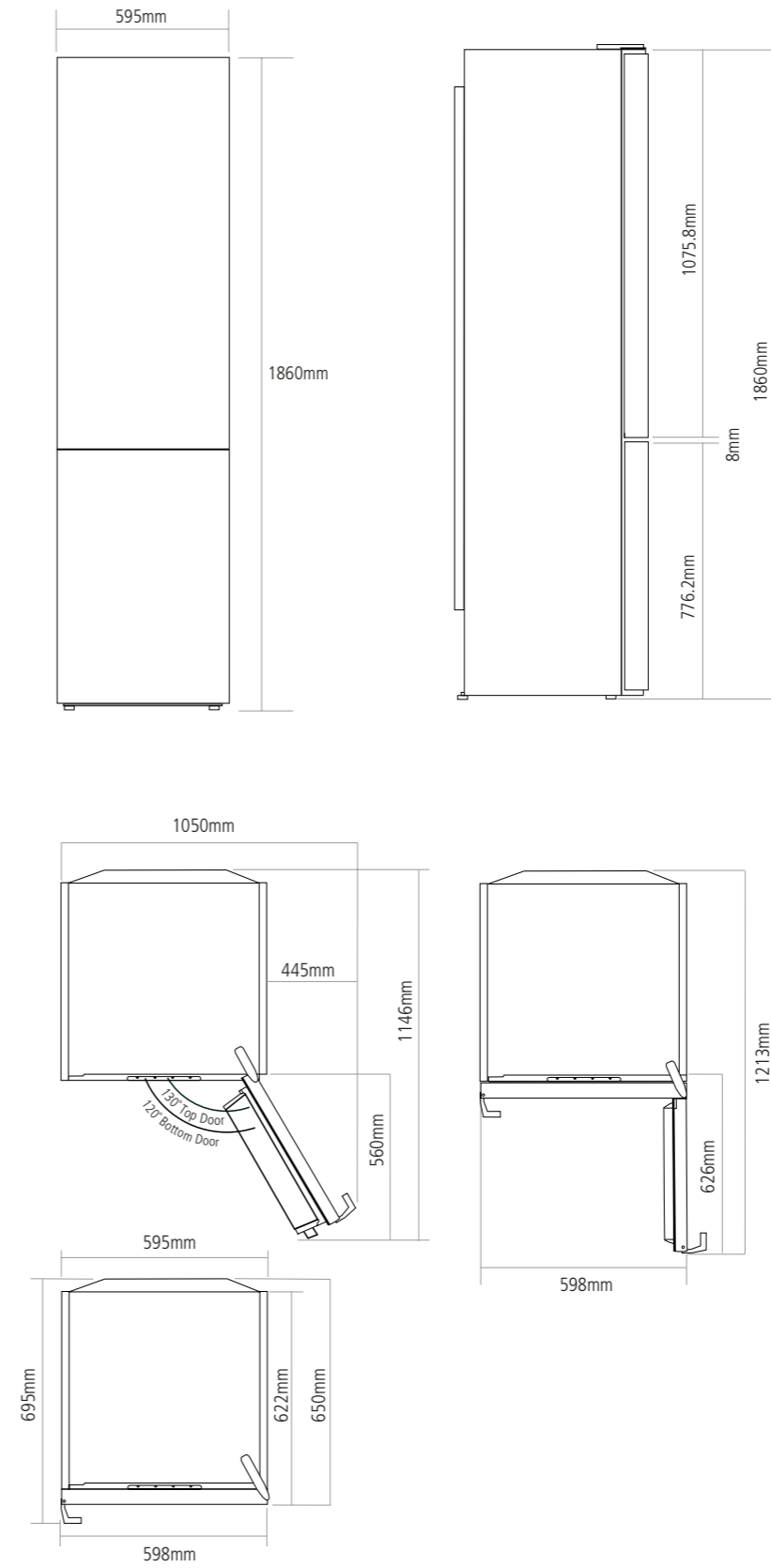

IN-COLUMN INTEGRATED REFRIGERATION

RI1800/RIF1801

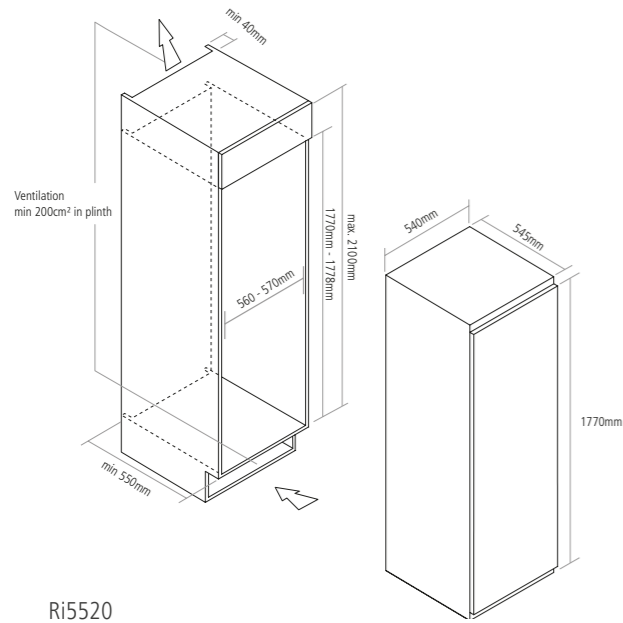

Ri7321

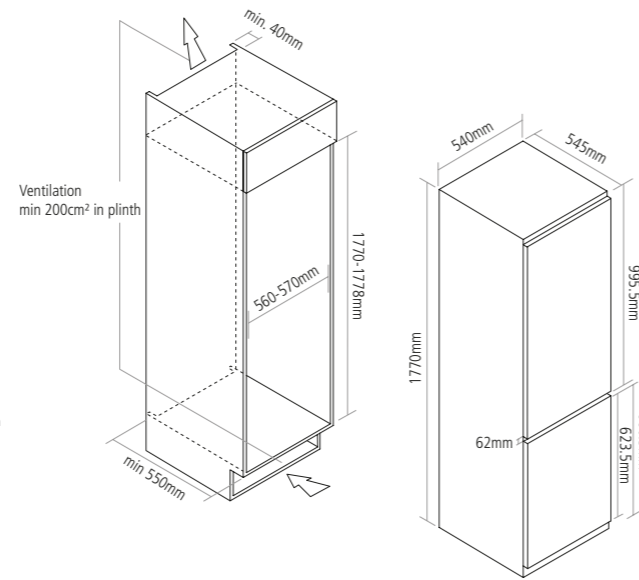

IN-COLUMN INTEGRATED REFRIGERATION

RI5508 / Ri5501

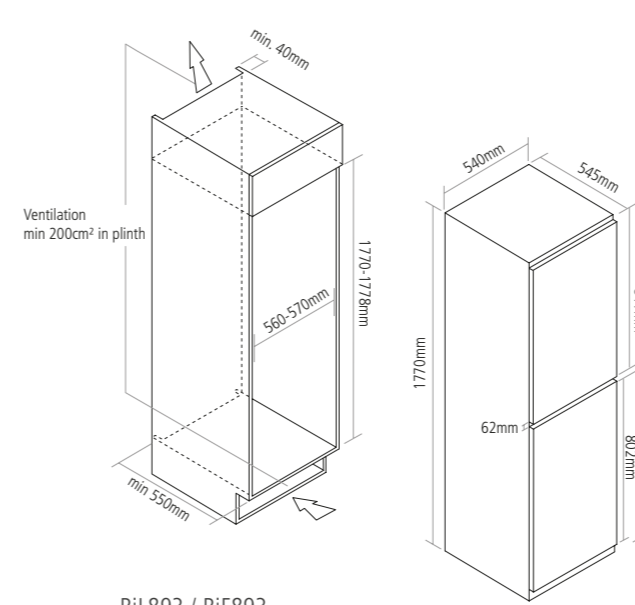

RiL126 / RiF126

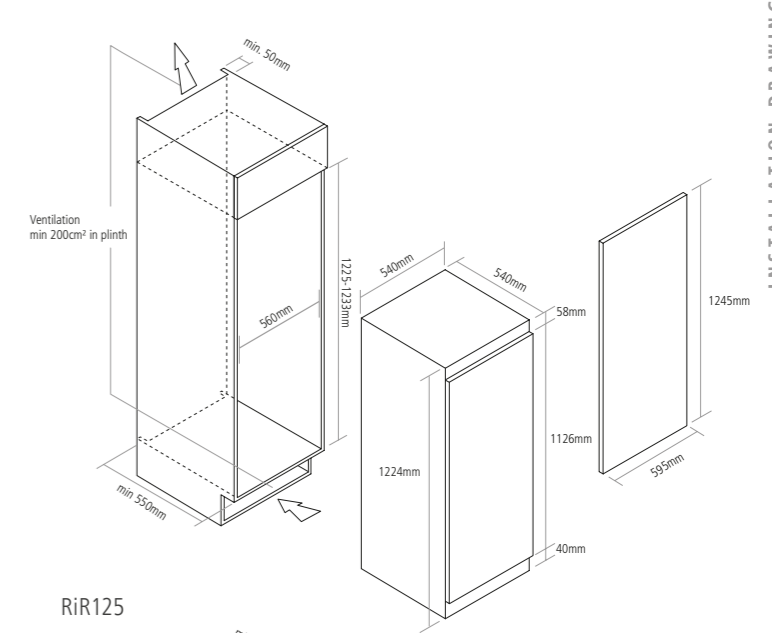

Ri5520

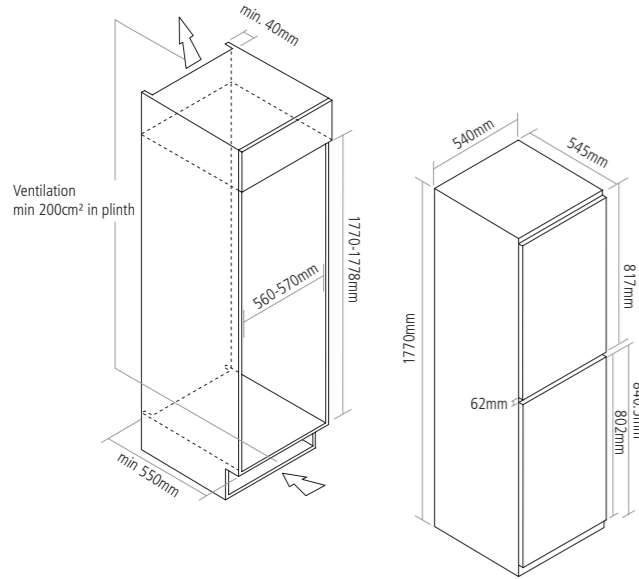

RiL1796

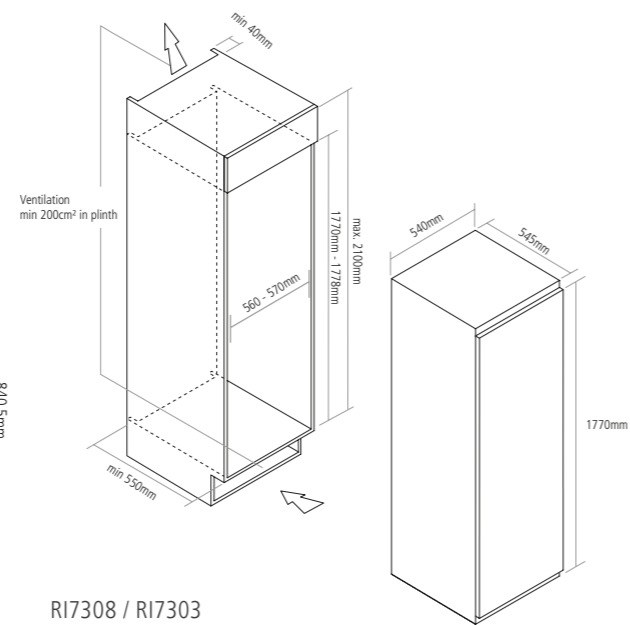

RiL893 / RiF893

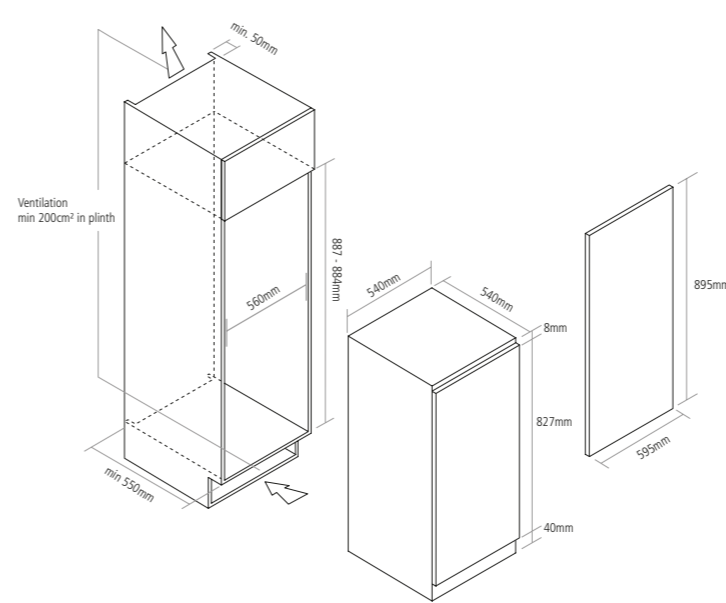

RiR125

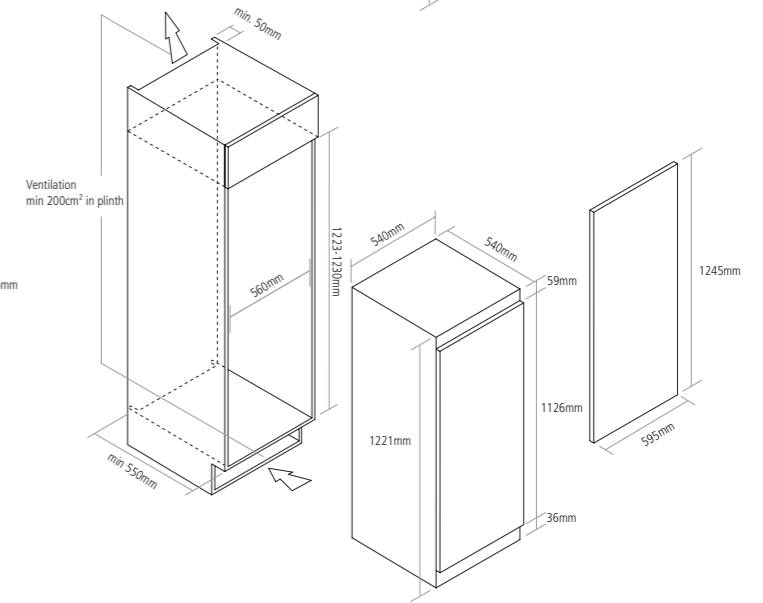

RIF1797

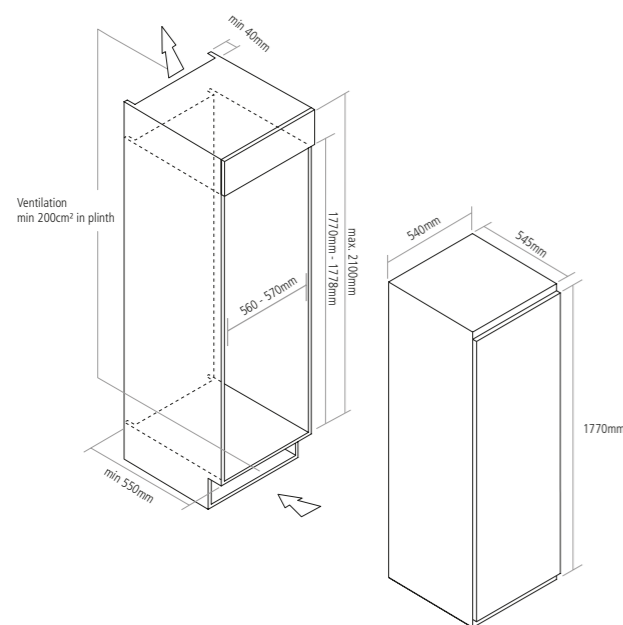

Ri7308 / Ri7303

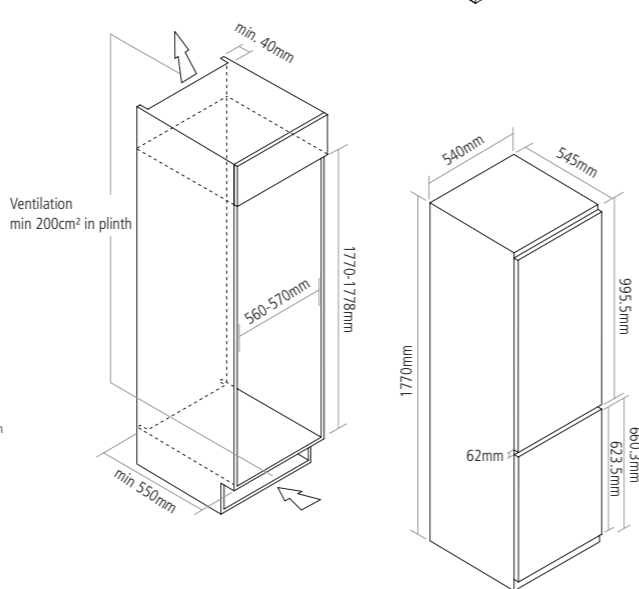

BUILT-UNDER INTEGRATED REFRIGERATION

RBL6 / RBF6 / RBR8

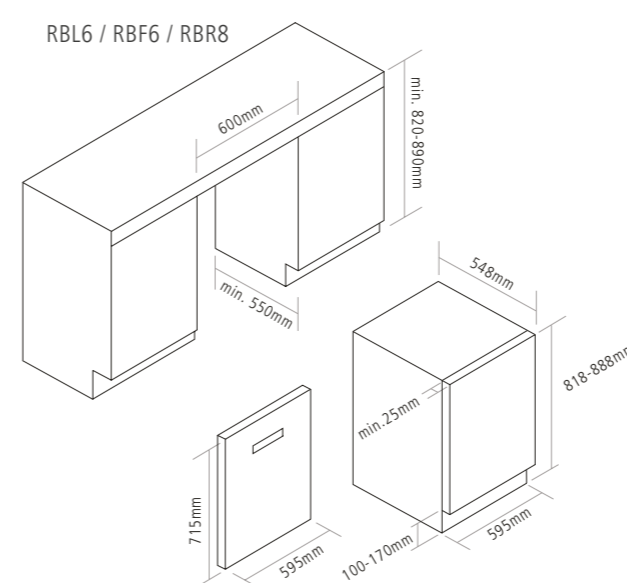

UNDERCOUNTER WINE CABINETS

Wi6161

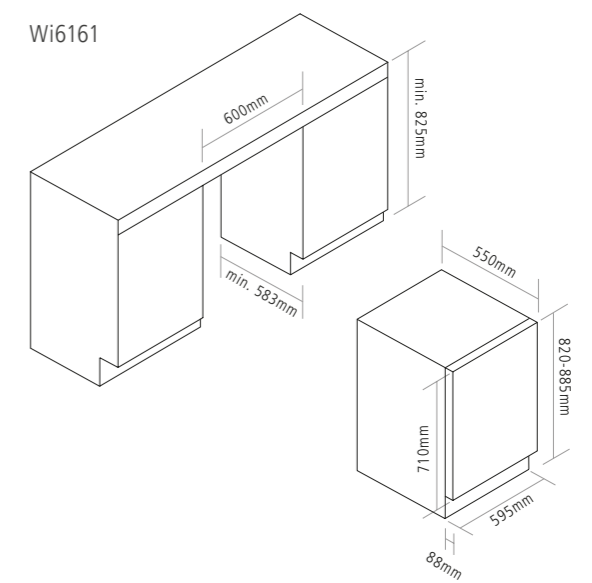

UNDERCOUNTER WINE CABINETS

Wi6235BG / Wi6234

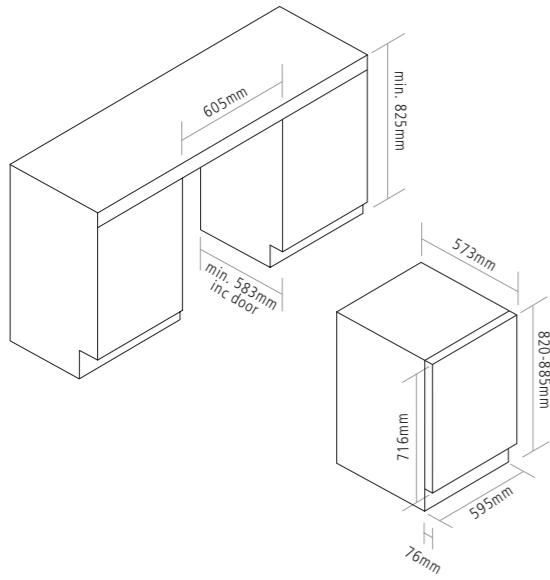

Wi6150 / Wi6155BG / Wi6135 / Wi6136 / Wi6143BG / Wi6142

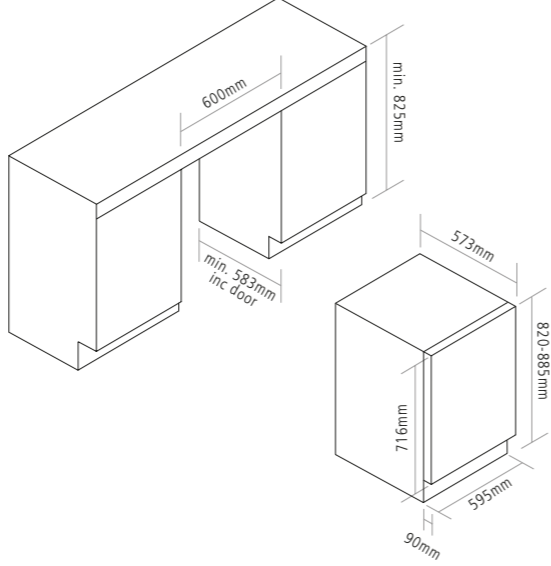

Wi3150 / Wi3155BG / Wi3126 / Wi3125

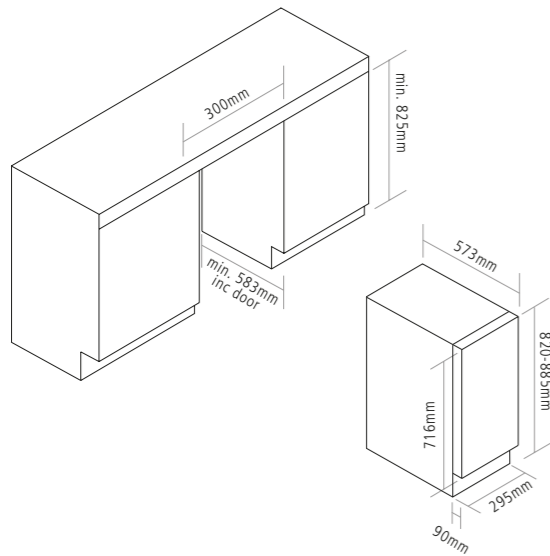

Wi158BG / Wi159

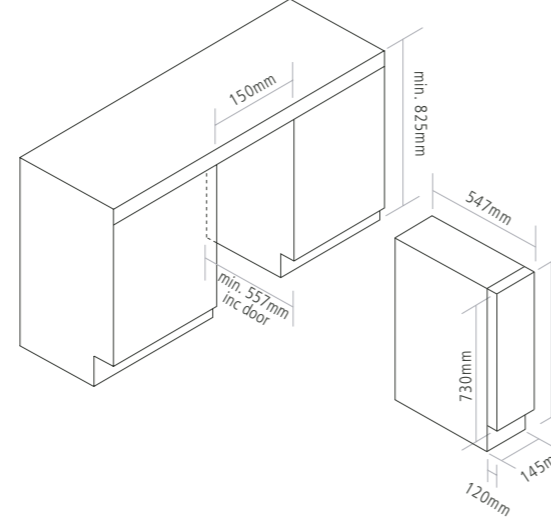

IN-COLUMN WINE CABINETS

WC6530

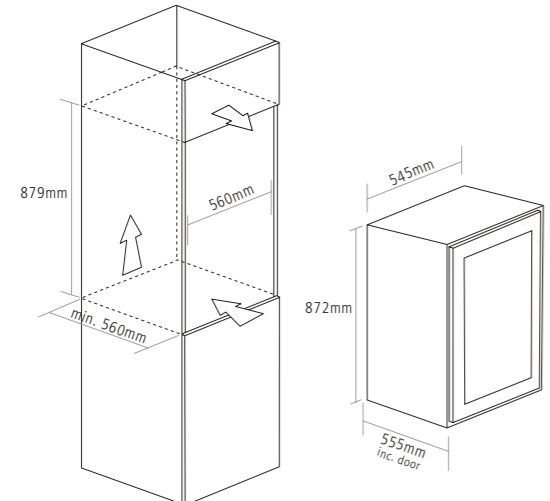

WC6130

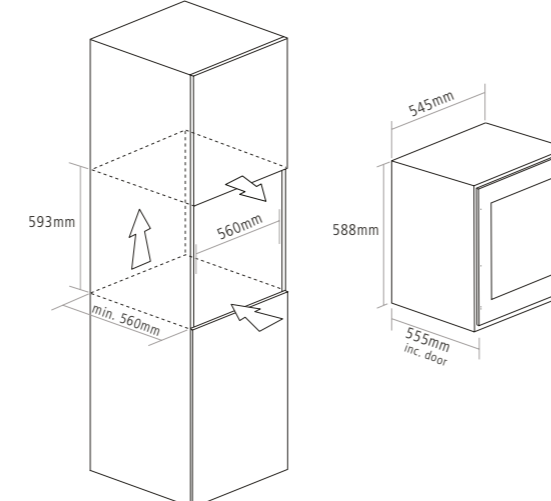

IN-COLUMN WINE CABINETS

WC1801

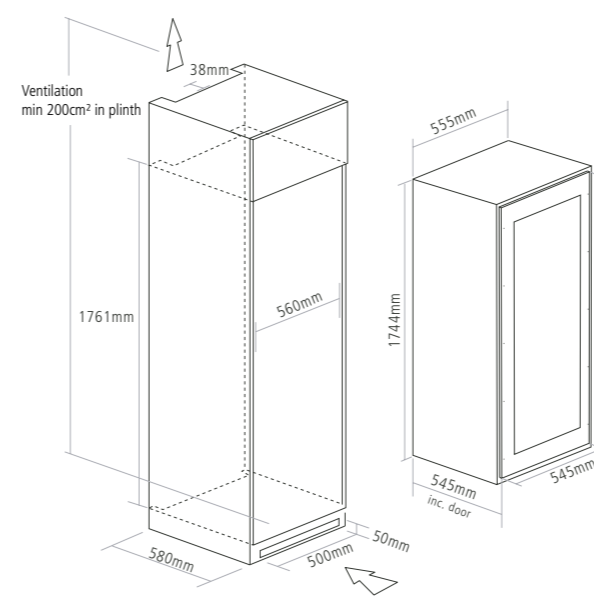

WC6100

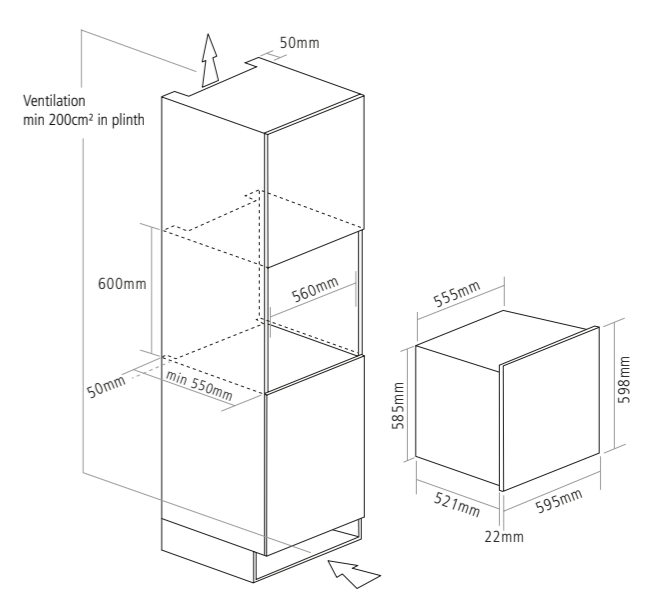

WC1796BG / WC1792

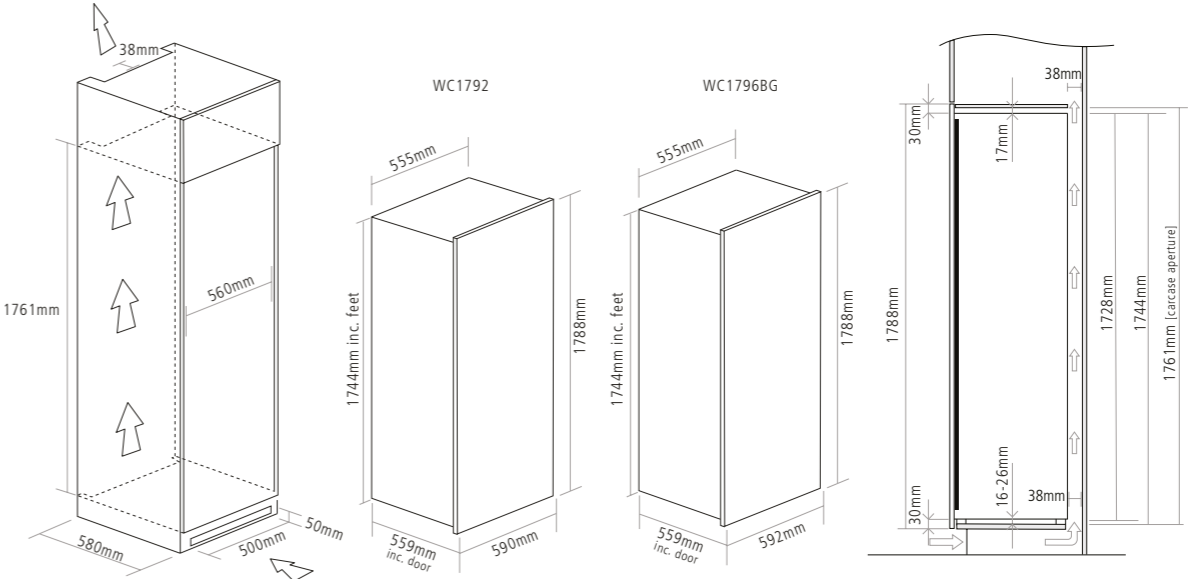

Please note: once installed the appliance door may not sit completely flush with the kitchen furniture door.
Dimensions may vary +/- 2mm due to manufacturing tolerances

WC6521BG / WC6511

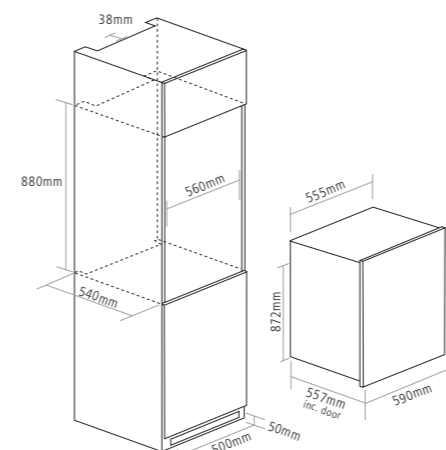

WC6411BG / WC6401

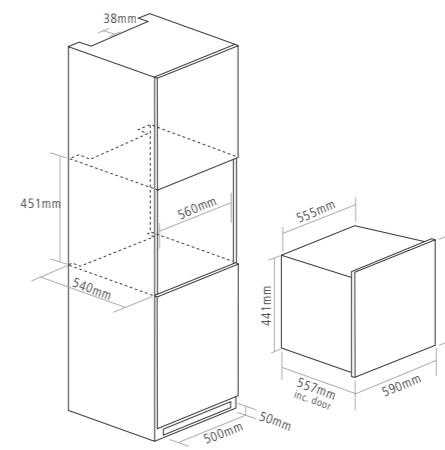

FREESTANDING WINE CABINETS

WF1553BG/WF1552

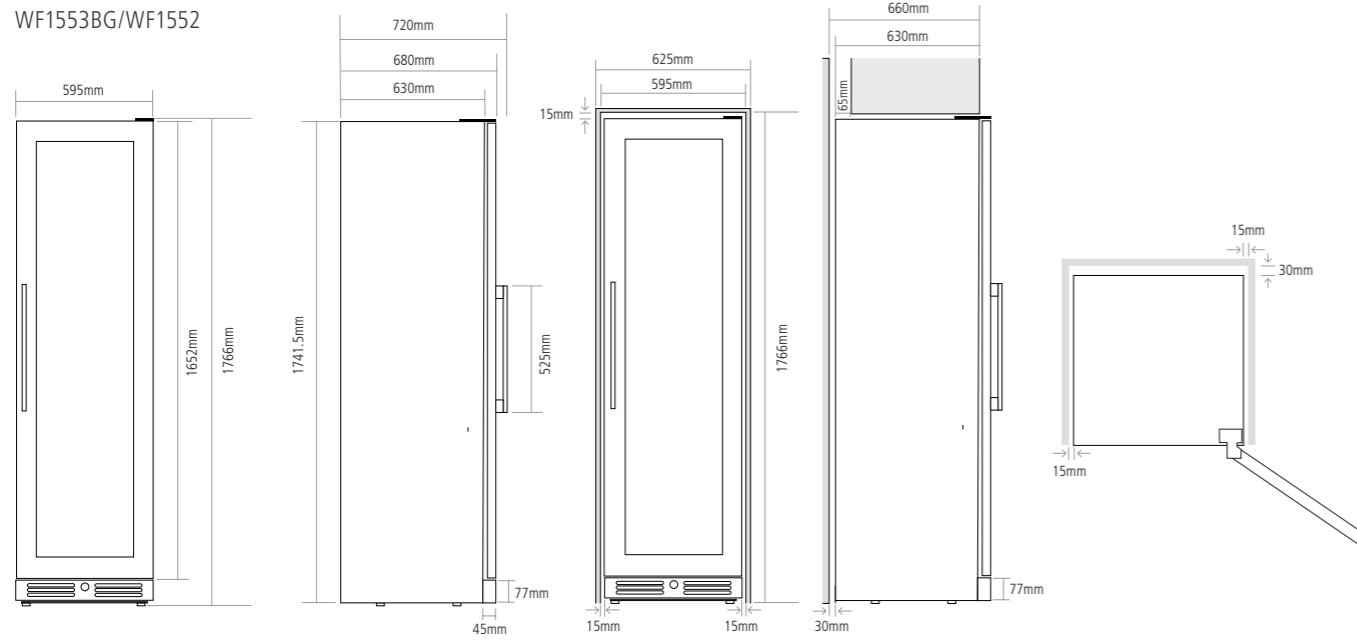

FREESTANDING

BUILT-IN

WF334

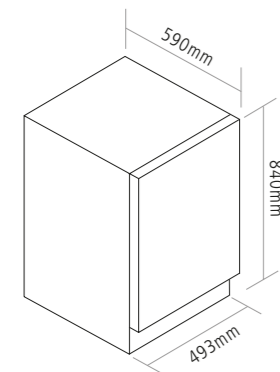

Ventilation requirements - Please allow an 127mm gap around the whole appliance when installed next to a wall, unit or in an alcove

DISHWASHERS

Di654 / Di632 / Di642

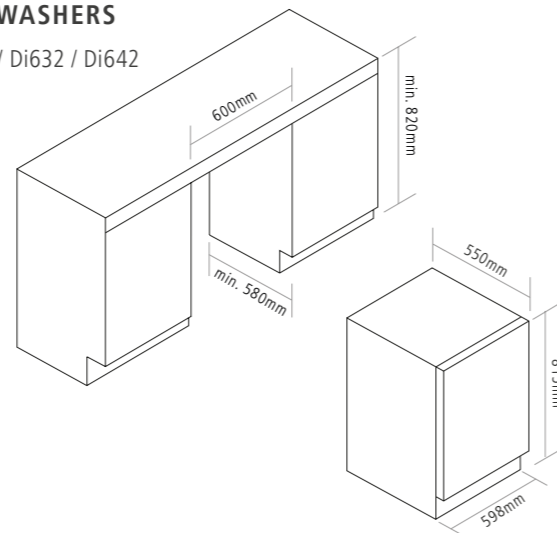

Di482

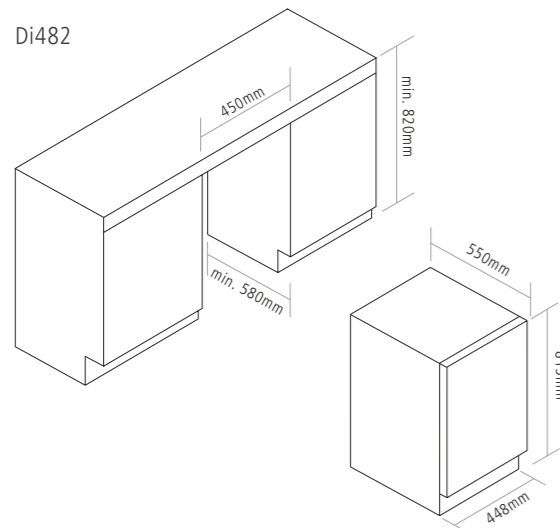

WASHING MACHINES

WMi4001

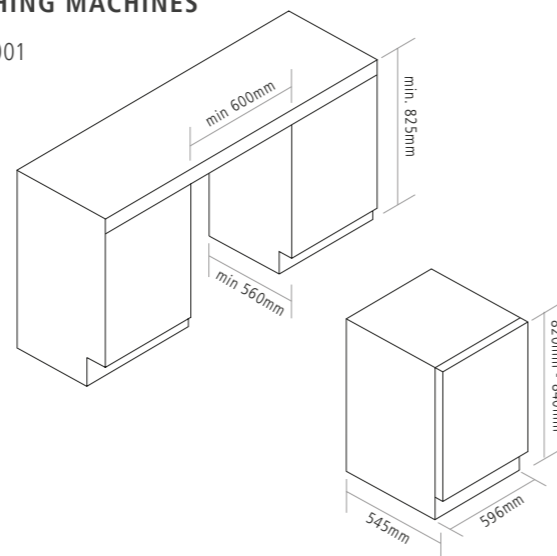

WASHING MACHINES

WMi3007

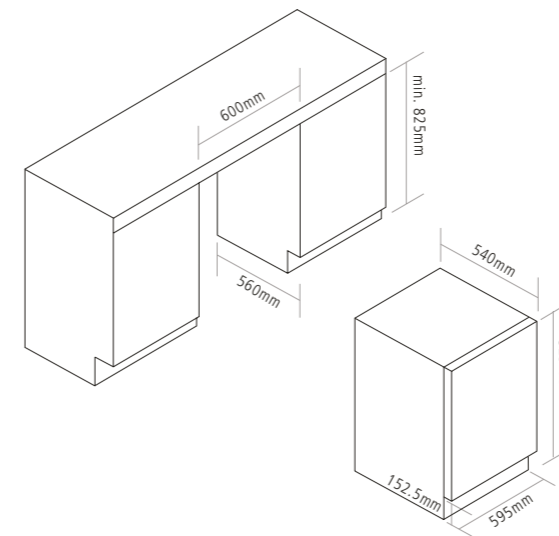

WMi3100

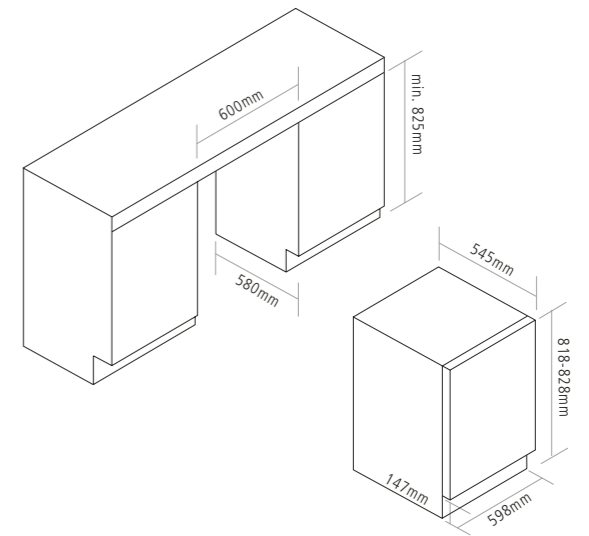

WASHER DRYER

WDi3310

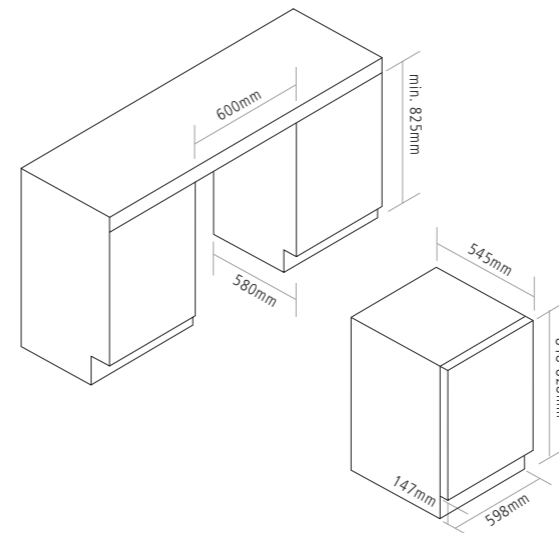

TUMBLE DRYER

TDi4001

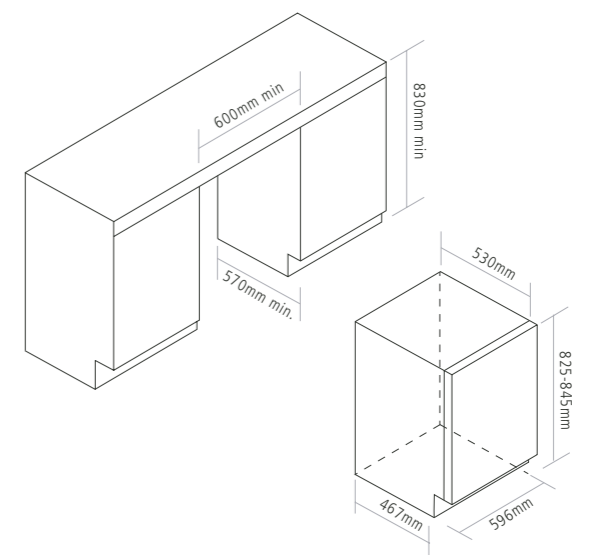

PLINTH HEATER

PH500H

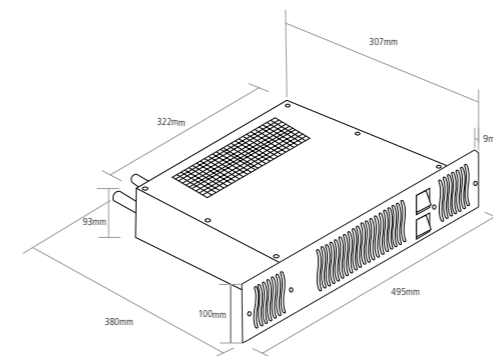

PH501E

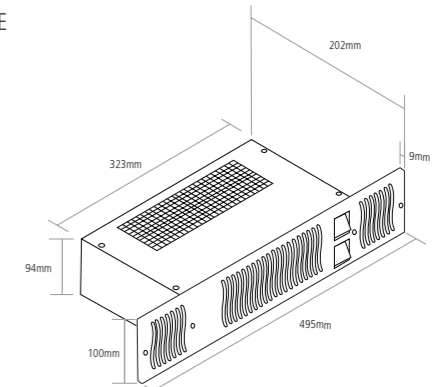



Performance Guaranteed.



Here at Caple, performance and reliability are the most important features considered when designing and manufacturing our products. With that in mind, we have developed Caple Care, an after-care solution comprising of three tiers to give you that extra peace of mind.



FREE 2 YEAR GUARANTEE

Across all Caple appliances we offer a free 2 year guarantee on parts and labour. When selecting the components to design your perfect kitchen it is important you have the right assurance without spending an extra penny. All you need to do is visit our website or call us on 0330 123 0998 to register your free 2 year guarantee.



5 YEAR EXTENDED COVER

Why not extend your cover to 5 years? Caple Care 5 years parts and labour cover means for a one off payment or a monthly fee you can protect your appliance for a total of 5 years [including your free 2 year guarantee] on all parts and labour for any of your Caple appliances.



OUT OF GUARANTEE

If you choose not to opt for a 5 year extended warranty, don't worry. Here at Caple we offer out of guarantee cover. So, if you are not covered under our extended warranty, for a fixed fee, we can still arrange a service call [including parts and labour] or a replacement product up to 6 years after the purchase date. Terms and conditions apply.

TO REGISTER YOUR FREE 2 YEAR GUARANTEE OR DISCUSS AN EXTENDED WARRANTY, CALL

0330 123 0998 OR VISIT CAPLE.CO.UK/REGISTER-YOUR-APPLIANCE

Lines are open 9am - 5pm Monday to Friday [excluding bank holidays].
Calls may be recorded and monitored for quality and training purposes.
Full Terms and Conditions can be found at www.caple.co.uk.

Issue: CA0125

Every effort has been made to reproduce colours and materials accurately, however due to the photography and print processes, colour variations may occur.

Due to our continued product development policy, we reserve the right to modify product specifications and/or dimensions without notice.

Please contact your retailer, call Caple direct on 0117 938 1900, email info@caple.co.uk, or visit our website at www.caple.co.uk for further product information.

E & O E